

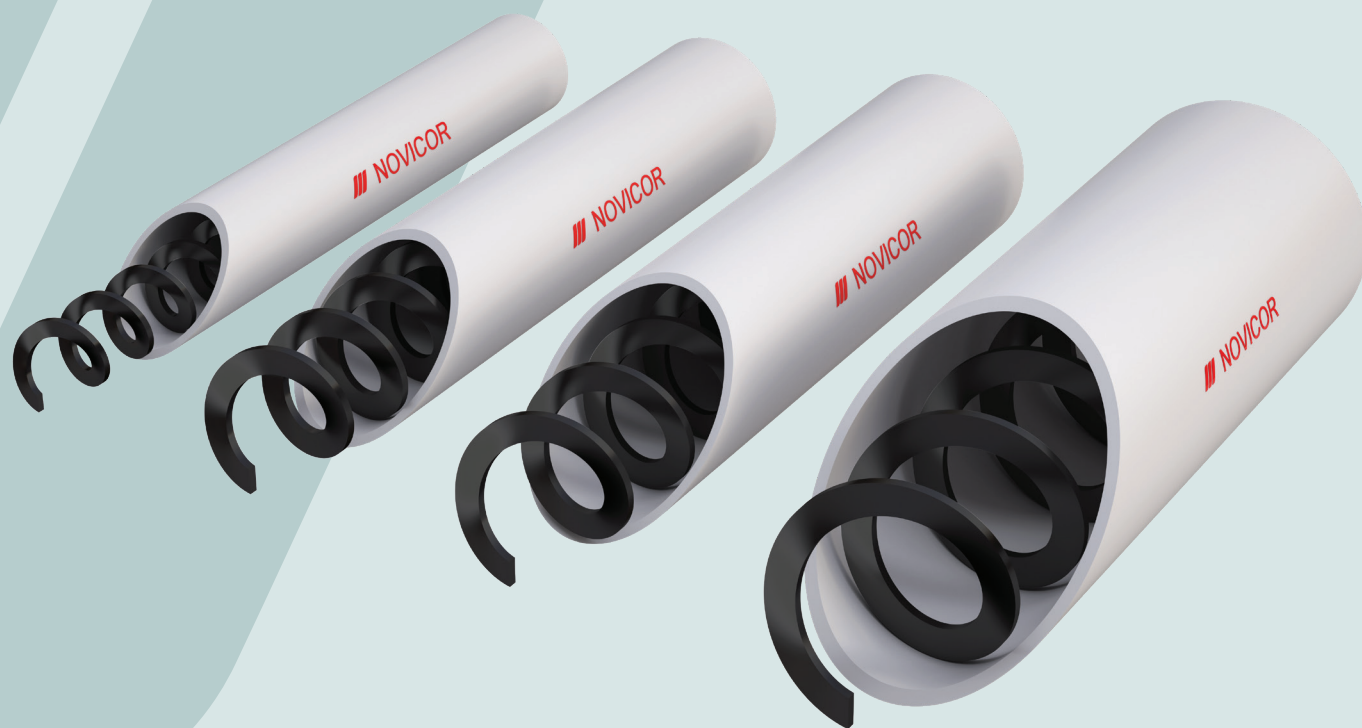

Flex-Auger™

Use and Assembly Guide



Original use and assembly guide

TABLE OF CONTENTS

Disclaimer

General information

I Instructions for the user

General safety rules	I – 2
Directions for operating the system	I – 3
Maintenance instructions	I – 4
Troubleshooting guide	I – 5

II Components

Environmentally friendly design	II – 1
Communication	II – 1
General view standard straight-line system	II – 2
Suspension	II – 4
Power unit	II – 9
Motor starter	II – 12
Control units	II – 13
Upper boots	II – 19
Transfer plate assembly - PE - black - 03000585	II – 20
Intake boots	II – 21
Spares set bearing cap holder	II – 35
Pellet guides	II – 35
Option: Thumper assemblies	II – 37
Extension boots	II – 38
Outlet drop assemblies with shut-off	II – 45
Automatic outlets	II – 47
Telescopic drop tube - 03100435	II – 50
Level switches	II – 51
Safety switch - 13000757	II – 55
Sensor holder + connection kit - 03103074	II – 55
Sensors	II – 56
Modular control unit	II – 57
Subtypes Flex-Auger system	II – 66
CDS system	II – 75
Tandem system	II – 78
Flex-Auger Mix system	II – 86

III Installation instructions

General safety rules	III – 2
Tools	III – 3
Directions for designing the system	III – 4
Elbow and tube specifications	III – 5
Elbow diagrams	III – 7
Graphs with maximum lengths	III – 11
Bin location	III – 17

Transport line location	III – 17
Suspension	III – 18
Control units	III – 25
Tubes	III – 28
Boot assembly	III – 38
Connection of the transport system to the bin	III – 43
Auger	III – 46
Option: Thumper	III – 49
Flow regulation	III – 50
Drop tubes	III – 50
Level switches	III – 54
Time delay	III – 56
Sensors	III – 56
Subtypes Flex-Auger system	III – 59
Electricity: watch out!	III – 81
Electrical symbols	III – 82
Wiring diagrams	III – 83
Technical information automatic outlet	III – 87
Motor protection	III – 89
Maximum cable lengths to the motors	III – 90

Disclaimer: The original, authoritative version of this manual is the English version produced by ROXELL bvba. Subsequent changes to any manual made by any third party have not been reviewed nor authenticated by Roxell. Such changes may include, but are not limited to, translation into languages other than English, and additions to or deletions from the original content. Roxell disclaims responsibility for any and all damages, injuries, warranty claims and/or any other claims associated with such changes, in as much as such changes result in content that is different from the authoritative Roxell-published English version of the manual. For current product installation and operation information, please contact the customer service and/or technical service departments of Roxell. Should you observe any questionable content in any manual, please notify Roxell immediately in writing to: ROXELL bvba - Industrielaan 13, 9990 Maldegem - Belgium.

General information

IMPORTANT: These instructions must be read, understood and all points observed by the user, the responsible and operating personnel.

Obey the legal regulations and the applicable rules

This concerns, among other things, the European regulations and directives transposed into national legislation and/or the laws, safety and accident prevention regulations that apply in the user's country.

During assembly, operation and maintenance of the installation the legal regulations concerned and the applicable technical rules must be obeyed.

Intended use

The installation has been designed solely for intensive livestock use and has been developed according to the applicable rules of good workmanship. Extra loading of the product is therefore prohibited. Any other use is considered to be improper use. The manufacturer is not responsible for damage resulting therefrom. The user bears sole responsibility.

Not-intended use

All use different than described in point 2 [Intended Use](#) is at the responsibility of the end user.

Liability

The (Extended) Warranty will not apply if any of the following has occurred: failure to conduct incoming goods inspection with regards to the Products, improper handling, transportation, modification or repair; accident, abuse or improper use; improper assembly, installation, connection or maintenance (having regard to Roxell's most current assembly, installation, connection and maintenance manuals); force majeure; negligence, lack of supervision or of maintenance on the part of customer; normal wear and tear; use of cleansing agents and disinfectants that are excluded in Roxell's most current use and maintenance manuals; use of cleansing agents and disinfectants in violation with the instructions received from the suppliers; or use of the Products in an ATEX- surrounding.

The (Extended) Warranty shall not apply in the event of a defect caused either by materials or accessories supplied by or services rendered by Customer; or by an intervention by a person or entity which is not authorized or qualified for carrying out such intervention. Furthermore, the (Extended) Warranty will only apply if the Products are used in livestock houses and if all parts or components of the Products are supplied by Roxell.

Roxell will not be liable for any damages caused due to improper use, assembly, installation, connection or maintenance of the Products. In this respect, the Customer expressly acknowledges that (i) all use, assembly, installation, connection or maintenance must be done in accordance with Roxell's most current assembly, installation, connection and maintenance manuals and (ii) the electrical installation on which the Products must be connected must be done in accordance with applicable local legislation on electrical installations. Furthermore, the Products must be tested both mechanically and electrically in accordance with state of the art techniques and applicable local legislation.

Personnel qualifications

User

The person who uses a function or operation of a product for their work or who works on the product. The user must be able to read the instructions for use and fully understand them. The user has knowledge of the functioning and construction of the installation.

Technically trained person

An expert who can assemble and maintain the installation (**mechanically/electrically**), and resolve malfunctions. On the basis of his/her technical training and experience, he/she has sufficient knowledge to be able to assess activities, recognize possible dangers and rectify dangerous situations.

Storage

Put all parts to be assembled in a room or at a location where the not yet assembled components are protected against weather influences.

Transport

Depending on the size of the parts and according to local circumstances and local legislation, the parts of the machine have to be transported with a forklift.

The forklift must be operated by a qualified person and in accordance with the rules of good workmanship. When lifting the load, always check if the center of gravity of the load is stable.

Dismantling

Dismantle the installation and its components in accordance with the environmental legislation of the country or the local authorities applicable at that time. All functioning products and exchange parts must be stored and disposed of in accordance with the applicable environmental regulations.

Environmental information for customers in the European Union



The European legislation requires that equipment marked with this symbol on the product or packaging must not be collected with unsorted household waste. This symbol indicates that the product must be disposed of separately. You are yourself responsible for the destruction of this and other electrical and electronic equipment via the disposal channels designated for that purpose by the national or local government. The correct destruction and recycling of this equipment prevents any negative consequences for the environment and health. For more information about destroying your old equipment, contact your local authorities or waste disposal service.

Information about waste disposal - electrical/electronic material for companies

1 In the European Union

If you have used the product for commercial purposes and you want to dispose of it, contact Roxell, who will give you information about the return of the product. It is possible that you will have to pay a disposal charge for the return and recycling. Small products (and small quantities) can be processed by the local collection agencies.

2 In other countries outside the European Union

If you want to dispose of this product, contact the local authorities for information concerning the correct disposal procedure.

The level of noise emission

The noise level of the installation in operation does not exceed 70 dB(A).

LOTOTO = Lock Out - Tag Out - Try Out

Everyone needs his own lock and tag (label), which can't be removed by other persons. Inform all the persons who are influenced by the procedure.

1 To block

- Localize all sources of energy (electric, hydraulic, pneumatic).
- Switch off.
- Take the relevant installation or process out of operation and lock it against reuse. You can do this by placing a padlock or other blocking mechanism (Lock Out).

2 To mark

Attach a sign, label or sticker to the padlock or blocking mechanism to reveal the nature and the expected duration of the work to other persons (Tag Out).

3 To check

- Check if the source of energy is switched off.
- Remove any remaining energy.
- Check that the installation or process is actually safe (Try Out).

Use personal protective equipment

Ensure you wear personal protective equipment (gloves, dust masks...).

Illuminance - sufficient lighting

- A minimum illuminance of 200 lux is necessary during usage, maintenance and installation.
- Provide at the installation (**portable**) emergency lighting in case of power failure.

Electrical equipment, control panels, components and drive units







- To operate control panels, there must be at least 70 cm of free space.
- Control panels must **always remain closed**. The key of the control panel must be in possession of an authorized person.
- The necessary measures must be taken by the user to keep out **rats, mice and other vermin from the control panels**.
- If electrical equipment, control panels, components and drive units are damaged, the system must be stopped **immediately!**
- Electrical equipment, control panels, components and drive units should **never be sprayed with water or other liquid!**
- Electrical equipment, control panels, components and drive units should **never be covered with any material**.

Information about the residual risks - used safety signs

There are three levels of danger, which you can recognize from the following signal words:

- **DANGER**
- **WARNING**
- **CAUTION**

The nature and source of the imminent danger and possible consequences of not obeying warnings is stated here!

Symbol	Meaning
	DANGER indicates a direct imminent danger that can result in a serious or even fatal accident if the safety measures are not respected.
	WARNING indicates a possible imminent danger that can result in a serious accident or damage to the product if the safety measures are not respected.
	CAUTION indicates possible, dangerous situations that can result in minor physical injury or material damage if the safety measures are not respected.
	This symbol refers to supporting information.
	Allowed
	Not allowed
	This symbol will be used to draw your attention to matters that are of great importance for your safety. It means: warning - follow the safety instructions. Disconnect the current and read the safety rules. In short: be alert. Ignoring these instructions can cause serious injuries or even death.

I Instructions for the user

General safety rules

Flex Auger Nr.: 031...

Transport system of dry feed for animals



DANGER: Carefully read the instructions before you use the system.

- Always turn off the electricity supply with the main switch, before you do any repair or maintenance work.
- Ensure that you wear personal protection equipment (gloves, dust mask).
- The system starts automatically. To have access to dangerous locations (for example automatic outlet, feed intake boots, drive units, control units or outlet holes in the tubes):
 1. Completely turn off the transport system.
 2. Ensure that nobody can turn on the system without your knowledge.
- Ensure that unauthorized persons cannot open the feed intake boot.
- Never allow unauthorized persons to enter the house in your absence.
- Pay attention when you winch up or winch down the poultry lines/circuits:
 - Stop the handling in case of any malfunctioning.
 - Never stand underneath the load when you winch up or winch down the poultry lines/circuits.
- If the auger stalls:
 1. Immediately turn off the system.
 2. Carefully read the troubleshooting guide and strictly follow the instructions.
 3. Contact a technically trained person. An auger under tension can cause very serious injuries when released.
- Regularly check the elbow/trough and/or tube connections. Tighten if necessary.
- Regularly check that the control unit and/or the motor handy box are properly closed.
- Ensure that the hopper cover (grill) or cover on the 100 kg hopper closes properly.

	Carefully read the User's Guide and Use & Assembly Guide.
	Unauthorized persons are forbidden.
	<p>This symbol will be used to draw your attention to matters that are of great importance for your safety. It means: Warning.</p> <ol style="list-style-type: none"> 1. Follow the safety instructions. 2. Disconnect the current. 3. Reread the safety instructions. <p>In short: be alert. It can cause serious injuries or even death.</p>

Directions for operating the system



ATTENTION: Actions on a grey background must be done by a technically trained person.

- **Never let the Flex-Auger run without feed:** This reduces the lifetime of the system considerably.
- Completely open the slide valve under the bin, when the system runs with mash or pellets.
- Always use a thumper for mash.
- Always use pellet guides for pellets. In this case, set the restrictor to minimum position.
- Ensure that there are sufficient animals eating from the last feed trough.



NOTE: The level switch is mounted low inside the last feed trough or hopper. The animals receive fresh feed when the feed trough is empty.

- The restrictor on the boot anchor adjusts the amount of feed taken by the auger.
 - Start any new system with the restrictor in minimum position.
 - Let the system run a while, before you adjust the feed flow. This ensures that the feed cleans the auger.
 - Move the restrictor as far away as possible from the anchor, to obtain a minimum feed flow.
 - In a Flex-Auger system with an extension boot: Ensure that the second part transports more feed than the first part.
 - If necessary, adjust the restrictor in the intake boot (beneath the weigher, daybin, bin ...).
- In case of a tandem system:
 - Always empty one bin after another.
 - **Never** feed from both bins at the same time.
 - If applicable: Remove the thumper, when one of the bins is empty.
- **Maximum running time per day:**
 - System without elbows: **4 hours**
 - System with elbows: **2 hours**
- **NOTE:** The maximum running times are considerably shorter for layer feed and any feed other than commercial feed for poultry and pigs!
- **Use of the slide valve:**

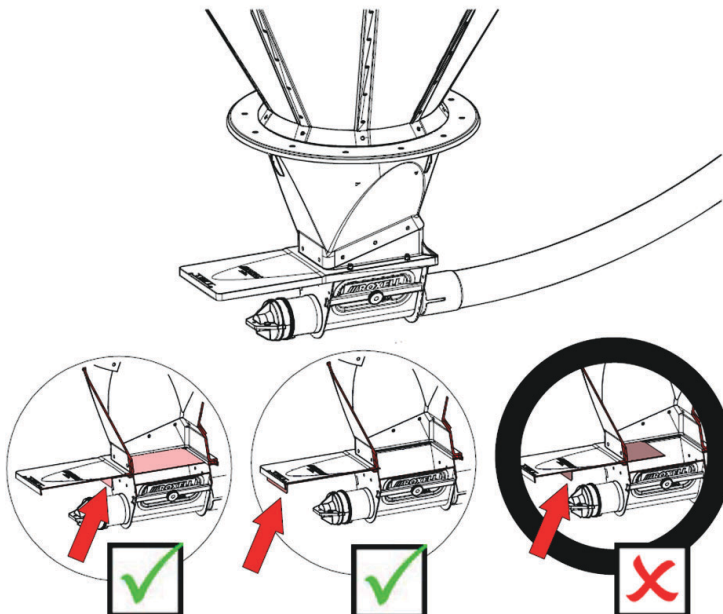

 Contact Roxell or your Roxell distributor for professional advice concerning the use of following feed:

- CCM (Corn Cob Mix)
- Feed mixed with CCM
- Soya
- Coarse soybean meal
- Wet feed

Without explicit authorization, all our warranties will expire and no claims will be accepted.

Also contact Roxell if you want to use strongly abrasive feed (for example hen feed ...).

Maintenance instructions

 **DANGER: Turn off the main switch first. Use personal protective equipment.**

 **ATTENTION: Actions on a grey background must be done by a technically trained person.**

Concerned part	Maintenance work	3-monthly	6-monthly	Yearly
Power unit				
	Make the fan dust-free.			X
	Check for possible damage to the electrical wiring.			X
Suspension				
	Check the suspension of the tubes and motors.	X		
	Check the cable.			X
Sensors/switches				
	Check the operation of the safety switch or sensor.		X	
	Check the electrical wiring.			X
Lines				
	Check the screws and bolts in the system after the first month and after each batch . Tighten if necessary.	X		
	Keep the tubes level.	X		
	Remove all feed from the system when the system will be out of use for a period.	X		



Troubleshooting guide



DANGER: Turn off the main switch first. Use personal protective equipment.



ATTENTION: Actions on a grey background must be done by a technically trained person.

Issue	Possible cause	Corrective action
Transport system does not run.	No supply voltage.	1. Check the fuses and/or reset the circuit breakers. 2. Check the cut-off switches and the current lead to the house. 3. Repair if necessary.
	Defective level switch.	1. Check that the level switch is installed correctly. 2. Find the cause of possible feed bridging in the control unit. 3. Check the level switch and replace if necessary.
	Defective safety switch in control unit.	Check the safety switch and replace if necessary.
	Defective motor.	Replace the motor.
Motor is overloaded after brief operation.	 NOTE: Never set the thermal-magnetic protection higher than the value mentioned on the motor label.	
	Wrong motor.	1. Check the motor power. 2. Replace the motor if necessary.
	Too low voltage: Motor runs too slowly and overheats.	1. Check the motor voltage. 2. Use the correct diameter for the connecting wires.
	Foreign object in auger: Motor runs, then stalls.	 DANGER: Carefully disconnect the auger. There might be tension on it. 1. Pull the auger out of the tubes. 2. Remove the object. 3. Clean the auger and the tubes. 4. Check the fat content, percentage of moisture etc. of the feed.
	Motor runs in reverse: Motor runs, then stalls. No feed is conveyed.	1. Turn the power off. 2. Change the wires. The motor shaft on the back of the motor must turn clockwise. 3. Check the auger for damages.
	Motor overheats.	Replace the motor.
Motor runs, but auger does not turn.	Broken bolt or worn-out set screw in drive shaft.	Replace the bolt or set screw.
Auger wears holes in straight tubes.	Kinked or poorly brazed auger.	See instructions.
Elbows wear out.	Too short or too long auger.	1. Adjust the auger length. 2. Install an extension boot if necessary.
Auger runs erratically.	Jammed or worn out boot bearing.	Replace the bearing.
	Too long auger.	Shorten the auger: 1. Close all the outlets. 2. Remove the bearing and anchor. 3. Disconnect the auger. 4. Let the system run for a short while. 5. Cut the auger at the rear end of boot. 6. Reinstall.
	Poor suspension of the tubes or too many elbows.	<ul style="list-style-type: none"> • Provide more suspension points. • Adjust the height. • Decrease the number of elbows.
	Kinked and/or poorly brazed auger scrapes along the tubes.	See Auger brazing .

Issue	Possible cause	Corrective action
Transport system continuously turns on and off.	Level switch not installed on the right spot in 100 kg hopper.	<ul style="list-style-type: none"> • Adjust the level switch position. • Use a VC11 or VC12 sensor if necessary.
	Sensor in tube.	
Feed accumulates in the extension boot.	Not sufficient feed drop from last outlet before the extension boot.	Provide 100 % feed drop.
	Time set too short on relay.	See instructions.
Second part (past the extension boot) does not start.	Defective level switch on first part.	Check the level switch and replace if necessary.

	55	75	90	90HD	125
Feed transport capacity (kg/h) (*)	520	1300 (1) 600 (2)	2400 (1) 3100 (2) 3900 (3)	3100	5400 (1) 10400 (2)
Feed amount /m tube (kg)(*)	0.70	1.90	2.50	2.50	4.80
Maximum length (m) (3 m inclination)	60 (90**)	60	42	60 (no inclination)	28
Max run time/day (h) (****)					
Elbow	Tube				
N	N	2			< 2
S	N	not applicable	4		
D	N	not applicable			4
No elbow	N	4			
S	S	not applicable	4		
Power unit kW (***) 3 phase – 50 Hz	0.37	0.75 (1) 0.37 (2)	0.75 (1) 1.1 (2) 1.5 (3)	1.5	1.1 (1) 1.5 (2)
RPM – 50 Hz	350	350 (1) 175 (2)	350 (1) 450 (2) 550 (3)	450	290 (1) 390 (2)
Power unit kW (***) 3 phase – 60 Hz	0.4	0.9 (1) 0.4 (2)	0.9 (1) 1.3 (2) 1.8 (3)	1.8	1.3 (1) 1.8 (2)
RPM – 60 Hz	420	420 (1) 210 (2)	420 (1) 540 (2) 660 (3)	540	348 (1) 468 (2)
Max. pellet diameter (mm)	6	8	9 12 (w/auger 75)	9	9
Outside diameter tube (mm)	56	75	89	89	127
Wall thickness tube (mm)	2.5	3.2	3.4 (N) 1.5 (S)	3.4 (N) 1.5 (S)	5 (N) 2 (S)
Elbow material	(N)	(N)	(N) or (S)	/	(N) (D) or (S)
Elbow radius (m)	1.5	1.5	1.5	/	1.7/2.2
Maximum inclination (****)	75°	75°	75°	horizontal!	45°
Suspension points	Novicor: every 1.5 m / steel : every 3 m				
Outside diameter auger (mm)	38.60	60.45	68.33	73.45	94.60
Inner diameter auger (mm)	22.60	36.57	44.45	44.45	65.60
Auger pitch (mm)	31.4	41.4	50.8	54.1	66 (1) 85 (2)

(*) For commercial mash, crumble or pellets (diameter 3 mm) with a specific weight of 0.65 kg/dm³ and full tube application!

Under horizontal installation upper boot

With restrictor or tandem inline, max. capacity - 25 %

With 60 Hz motor, max. capacity + 20 %

Pellets diameter $\frac{3}{4}$ 6 mm, max capacity - 20 %

*(**) With fill points every 0.5 m and for pellets only (not for meal)!*

*(***) 0.75 kW = 1 HP!*

*(****) Deviation from the maximum inclination advice will affect the capacity considerably. For specific uses, like breeder applications, check the U&A Guide.*

*(*****) For abrasive feed, such as layer feed and any other than commercial feed for poultry and pigs, the maximum running times are considerably shorter.*

(N) = Novicor, (S) = Steel, (D) = Densicor



Inbouwverklaring betreffende niet voltooide machines (Richtlijn 2006/42/EG, Bijlage II.1.B)
Declaration of incorporation of partly completed machinery (Directive 2006/42/EC, Annex II.1.B)

Fabrikant/Manufacturer:
Roxell, Industrielaan 13, 9990 Maldegem
Tel: +32 50 72 91 72
Fax: +32 50 71 67 21

Verklaart geheel onder eigen verantwoordelijkheid dat het product:
Declares on its own responsibility that the product:

Flex-Auger Nr: 031...
Transportsysteem voor droogvoeder van dieren.
Transport system of dry feed for animals.

Waarop deze verklaring betrekking heeft, in overeenstemming is met:

- de volgende richtlijnen: 2006/42/EG (Machinerichtlijn); 2014/30/EU (Elektromagnetische Compatibiliteit).
- de geharmoniseerde Europese Normen: EN ISO 13857; EN 349; EN ISO 12100; EN 60204-1; EN 61439-1; EN 61439-2

Het is verboden bovengenoemd product in gebruik te stellen voordat de machine waarin het wordt ingebouwd in overeenstemming met de bepalingen van de Machinerichtlijn is verklaard.

Tevens verbindt de fabrikant (of zijn gemachtigde) zich om op met redenen omkleed verzoek van de nationale autoriteiten de relevante informatie over deze niet voltooide machine door te geven. De wijze van doorgifte is digitaal. De wijze van informatievervalsing laat de intellectueel-eigendomsrechten van de fabrikant van de niet voltooide machine onverlet

(NL)

Relating to this declaration is in accordance with

- The following directives 2006/42/EC (Machinery Directive); 2014/30/EU (Electromagnetic Compatibility).
- The harmonised European standards: EN ISO 13857; EN 349; EN ISO 12100; EN 60204-1; EN 61439-1; EN 61439-2

This product must not be put into service until the machinery into which it is to be incorporated has been declared in conformity with the provisions of the Machinery Directive.

The manufacturer (or its agent) also undertakes, at the duly reasoned request of the national authorities, to provide the relevant information concerning this partly completed machinery. The method of transmission will be digital. The manner in which the information is provided does not prejudice the manufacturer's intellectual property rights concerning the partly completed machinery.

(EN)

03000601

Plaats, Datum / Place, Date: Maldegem, 01/01/2020

.....
Dhr. Gino Van Landuyt
Managing Director

"This part may only be filled out if all built-in subparts are delivered by Roxell"

EG-verklaring van overeenstemming (Richtlijn 2006/42/EG, Bijlage II.1.A)
EC-declaration of conformity (Directive 2006/42/EC, Annex II.1.A)

Wij/We _____
(naam installateur/name fitter)

(volledig adres en land/complete address)

Verklaren geheel onder eigen verantwoording de
Declare completely on own justification that

(naam machine/name machinery) (nummer CE-label/number CE-label)

In een installatie te hebben ingebouwd geheel volgens de Roxell-voorschriften en in overeenstemming met de bepalingen van de Machinerichtlijn.
Has been incorporated in conformity with the provisions of the Machinery Directive and the prescriptions of Roxell bvba

(plaats, datum/place, date) (naam, handtekening/name, signature)

De EG-verklaring van overeenstemming / inbouwverklaring betreft uitsluitend de machine of niet voltooide machine in de toestand waarin zij op de markt is gebracht, met uitsluiting van de later bijvoorbeeld door de verdeler en/of installateur en/of eindgebruiker toegevoegde componenten en/of verrichte bewerkingen.

The EC-declaration of conformity / declaration of incorporation relates exclusively to the machinery or partly completed machine in the state in which it was placed on the market and excludes components which are added and/or operations carried out thereafter for instance by the distributor and/or the installer and/or the final user.

II Components

Environmentally friendly design

The motors comply with the Ecodesign legislation.

Communication

For all communication concerning parts/spare parts refer to the appropriate part number (not part name).

General view standard straight-line system

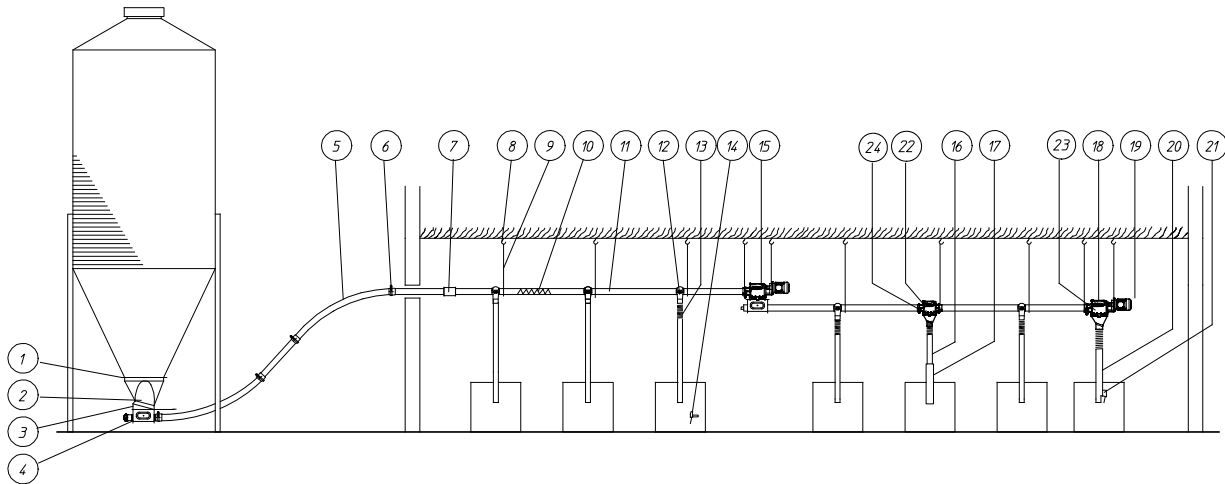

Component numbers

Key	Name	Number			
		Mod. 55	Mod. 75	Mod. 90	Mod. 125
1	UNIVERSAL COLLAR	03102001	03102001	03102001	03102001
2	UPPER BOOT-15°-PE -BLACK	03000577	03000577	03000577	03000577
	QUADRUPLE BOOT	03001243	03001243	03001243	03001243
	QUADRUPLE BOOT ASSY 0°	03102847	03102847	03102847	03102847
	MULTIPLE BOOT 3 FA125	03001293	03001293	03001293	03001293
	MULTIPLE BOOT 4 FA125	03001277	03001277	03001277	03001277
3	TRANSFER PLATE ASSEMBLY PE BLACK	03000585	03000585	03000585	03000585
4	BOOT ASSEMBLY	03501335	03103850	03202629	03702141
	DOUBLE BOOT ASSY	03501343	03103868	03202637	-
	TANDEM IN LINE	-	03103876	03202645	03700580
	RETURN TANDEM	-	03102969	03202009	03700572
5	NOVICOR ELBOW 45°	03300977	03100542	03200326	03700051
	HARDENED STEEL ELBOW 45°	-	-	03200433	03700002
	DENSICOR ELBOW 45° Ø127 R2200	-	-	-	03701116
	HARDENED STEEL ELBOW 45°- Ø127 MM R2200	-	-	-	03701124
6	TUBE CLAMP ASSY	03600392	-	03200029	03700077
	HOSE CLAMP	-	03100658	03200250	-
	HOSE CLAMP Ø131-139 MM	-	-	-	03701196
	HOSE CLAMP Ø131-139 MM W/SCREWS	-	-	-	03702125
*7	TUBE CONNECTOR	03300274	03100583	03200383	03700382
8	SCREW HOOK 90 MM	05000872	05000872	05000872	05000872
	SCREW HOOK 160 MM	05000237	05000237	05000237	05000237
9	SUSPENSION CHAIN	05000021	05000021	05000021	05000021
10	AUGER	03300571	03100187	03200409	03700085
	AUGER HEAVY DUTY	-	-	03200128	-
	AUGER - FA125 - PITCH 85 MM	-	-	-	03701188
	AUGER - FA125 - PITCH 66 MM / Ø104 MM	-	-	-	03702061
11	NOVICOR TUBE - 3 M	03300084	03100559	03200300	03700069
	METAL TUBE - 3 M	-	-	03200102	03700200
12	OUTLET DROP ASSY W/SHUT-OFF	See Outlet drop ass'y w/shut-off model 55, 75, 90 and 125.			
13	FLEXIBLE TUBE ASSY Ø70 MM	05000047	05000047	-	-
	FLEXIBLE TUBE ASSY Ø85 MM	-	-	03100633	03100633
	FLEXIBLE TUBE ASSEMBLY Ø110 MM	-	-	-	03700143
	REDUCTION PIECE Ø104.5-85 MM	-	-	-	00703074
14	HOPPER LEVEL SWITCH	03100864	03100864	03100864	03100864
15	EXTENSION BOOT	03501350	03103884	03202652	03701092

Key	Name	Number			
		Mod. 55	Mod. 75	Mod. 90	Mod. 125
16	PLASTIC DROP TUBE Ø70 MM - 2.5 M	05000054	05000054	-	-
	PLASTIC DROP TUBE Ø85 MM - 2.5 M	-	-	03100625	03100625
17	TELESCOPICAL DROP TUBE	03100435	03100435	-	-
18	CONTROL UNIT	03501236	03103256	03202496	03701211
19	POWER UNIT	See Power unit .			
20	PLASTIC DROP TUBE Ø85 MM - 2.5 M	03100625	03100625	03100625	03100625
21	DROP TUBE LEVEL SWITCH	03101102	03101102	03101102	03101102
	DROP TUBE LEVEL SWITCH WITH DELAY	03100872	03100872	03100872	03100872
22	AUTOMATIC OUTLET DROP ASS'Y	04906954	04906962	04906913	04909364
23	DROP 105 MM (METAL)	-	-	-	03700622
23	DROP FOR DROP TUBE Ø110	-	-	-	13702988
24	TUBE CLAMP ASSY	13000021	03900065	04901658	-
*	OPTION				

Suspension

Suspension and line components

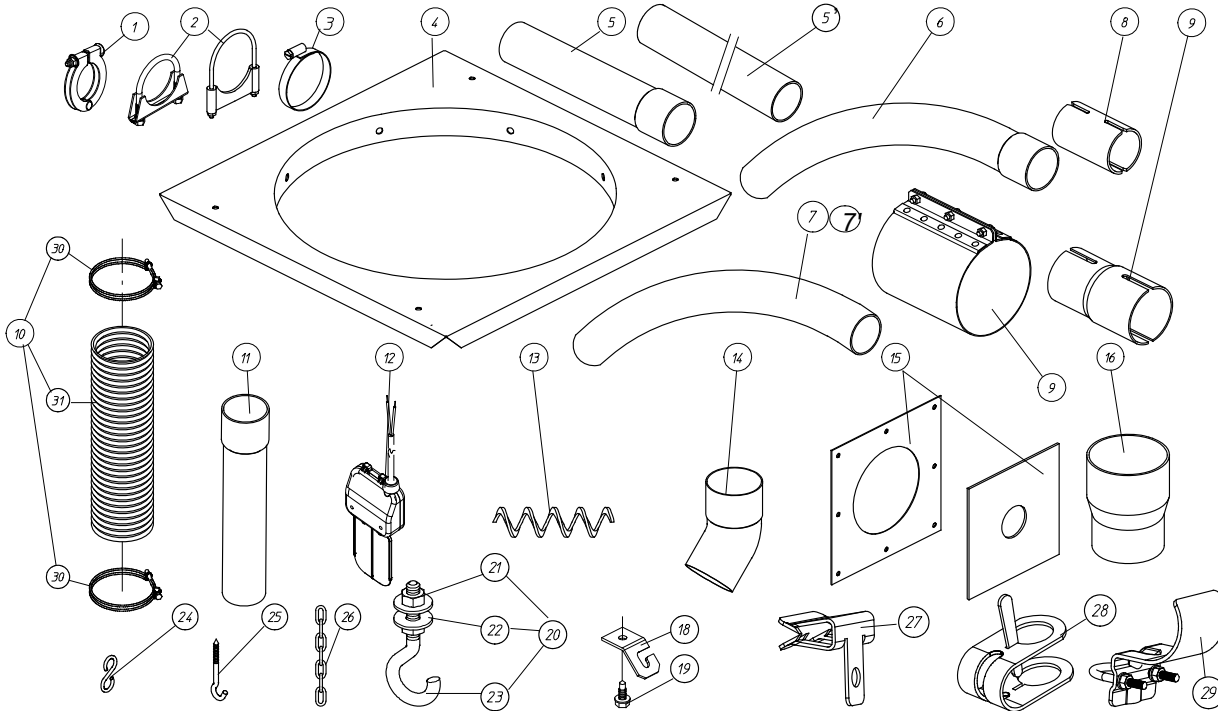

Key	Name	Part Nr.	Key	Name	Part Nr.
1	TUBE CLAMP ASSEMBLY Ø63	03600392	11	PLASTIC DROP TUBE Ø70MM - 2.5M	05000054
2	TUBE CLAMP ASSEMBLY Ø95	03200029		PLASTIC DROP TUBE - Ø85MM - 2.5M	03100625
	TUBE CLAMP ASSEMBLY Ø140	03700077		PLASTIC DROP TUBE - Ø110M - 5.0M	03700135
	TUBE CLAMP ASSEMBLY Ø80	03900065	12	LEVEL SWITCH ASS'Y	13104500
	HOSE CLAMP Ø131-139	03701196	13	AUGER - FA 55	03300571
3	TUBE CLAMP Ø60	13000021		AUGER - FA 75	03100187
	HOSE CLAMP Ø70-90	03100658		AUGER - FA 90	03200409
	HOSE CLAMP Ø80-100	03200250		AUGER FA90-HD	03200128
	HOSE CLAMP Ø89 x 20	04901658		AUGER - FA 125	03700085
	HOSE CLAMP Ø131-139 W/SCREWS	03702125		AUGER - FA 125 - PITCH 85MM	03701188
4	UNIVERSAL COLLAR	03102001	14	PVC ELBOW 45° - Ø70MM	03100294
5	NOVICOR TUBE LG=3M - Ø56MM	03300084	15	SEAL & SEAL RING	03600277
	NOVICOR TUBE LG=3M - Ø75MM	03100559		RUBBER SEAL WITH SEAL RING	03100849
	NOVICOR TUBE LG=3M - Ø89MM	03200300		SEAL & SEAL RING	03200474
	METAL TUBE LG=3M - Ø89MM	03200102		SEAL AND SEAL RING	03700184
	NOVICOR TUBE LG=3M - Ø127MM	03700069	16	REDUCTION PIECE Ø104.5-85 MM	00703074
5'	METAL TUBE LG=3M - Ø127MM	03700200	18	SUSPENSION PLATE	00103069
	TUBE Ø32 x 1.2 - 2.9M	03103066	19	SELF DRILLING SCREW 6.3 X 25	00103077
	TUBE 3.05M WITHOUT HOLES	00102269	20	SUSPENSION HOOK M6x60	05000302
	METAL TUBE Ø56MM LG=3000MM	04801346	21	NUT M6 - DIN 934	20100210

Key	Name	Part Nr.	Key	Name	Part Nr.
6	NOVICOR ELBOW 45° - Ø56MM	03300977	22	WASHER 6.4 X 18 X 1.5 - DIN 9021	20100756
	NOVICOR ELBOW 45° - Ø75MM	03100542	23	SCREW HOOK M6 X 60	20103156
	NOVICOR ELBOW 45° - Ø90MM	03200326	24	"S" HOOK	05000013
	NOVICOR ELBOW 45° - Ø125MM	03700051	25	SCREW HOOK 90MM	05000872
	DENSICOR ELBOW 45° - Ø127MM	03701116		SCREW HOOK 160MM	05000237
7	METAL ELBOW 45° - Ø70MM	03800273	26	SUSPENSION CHAIN	05000021
	HARDENED STEEL ELBOW 45° - Ø90MM	03200433	27	CADDY CLIPS TYPE 4H58	20104220
	HARDENED STEEL ELBOW 45° - Ø125MM	03700002	28	BRACE KIT DOWN 1"-1"	04800587
	HARDENED STEEL ELBOW 45° - Ø127MM R2200	03701124		BRACE KIT DOWN 1"-3/4"	04800595
7'	PE - ELBOW 45° Ø90MM	03202718	29	BRACE KIT UP 1"-1"	04800603
	PE - ELBOW 45° Ø125MM	03700877		BRACE KIT UP 1"-3/4"	04800611
*8	TUBE CONNECTOR Ø56MM	03300274	30	FLEXIBLE CLAMP Ø93	13103346
	TUBE CONNECTOR Ø75MM	03100583		FLEXIBLE CLAMP Ø120	13700489
	TUBE CONNECTOR Ø90MM	03200383	31	FLEXIBLE TUBE	15000227
	TUBE CONNECTOR	03200169		FLEXIBLE Ø85	13103353
*9	CONNECTOR Ø70-75MM	03101946		FLEXIBLE Ø110	13700471
	TUBE CONNECTOR KIT	03700382	*	Option	
10	FLEXIBLE TUBE ASS'Y Ø70MM	05000047			
	FLEXIBLE TUBE ASS'Y Ø85MM	03100633			
	FLEXIBLE TUBE ASSEMBLY Ø110MM	03700143			

Suspension set for profile - 03702045

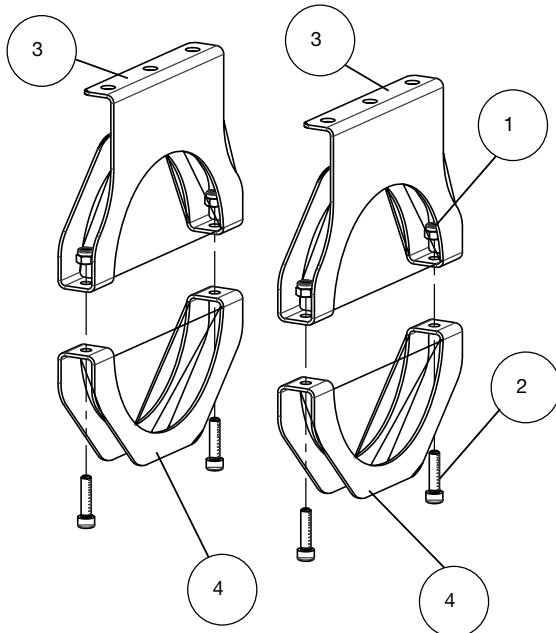

Key	Name	Part Nr.	Qt.
1	LOCKNUT M6 - DIN 985	20100400	4
2	SOCKET CAP SCREW M6x25-DIN 912	20100897	4
3	DENSICOR EXPANSION PLATE 3	13704028	2
4	DENSICOR EXPANSION PLATE 4	13704036	2

Hose clamp Ø131–139 mm with screws – 03702125

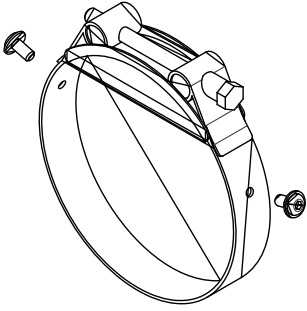

Option: General view suspension

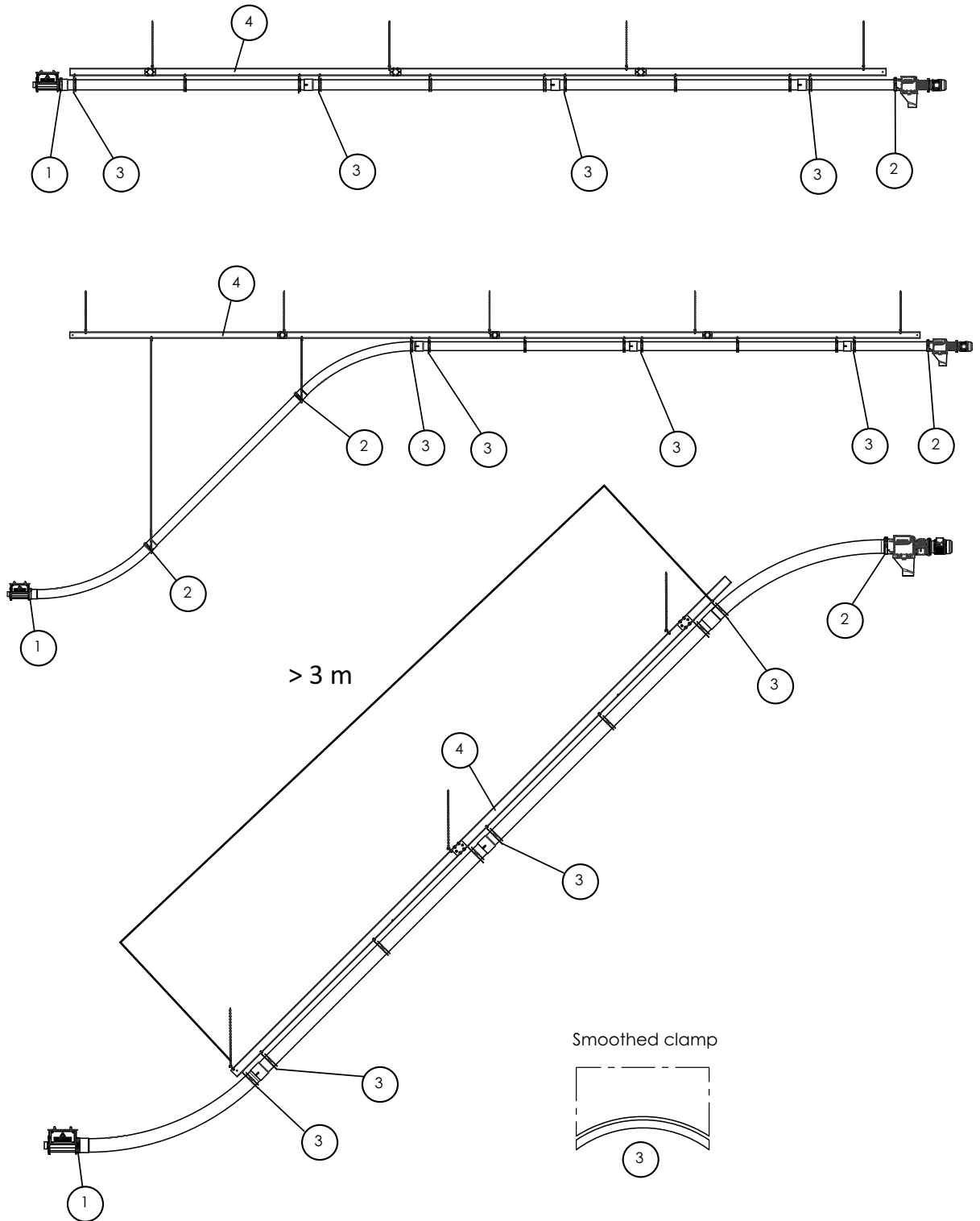

Key	Name	Part Nr.
1	HOSE CLAMP Ø131-139 MM	03701196
2	HOSE CLAMP Ø131-139 MM W/SCREWS	03702125
3	DENSICOR SUSPENSION SET FOR PROFILE	03702045
4	SUSPENSION PROFILE FLEX-AUGER	03001251

Option: Suspension profile Flex-Auger – 03001251

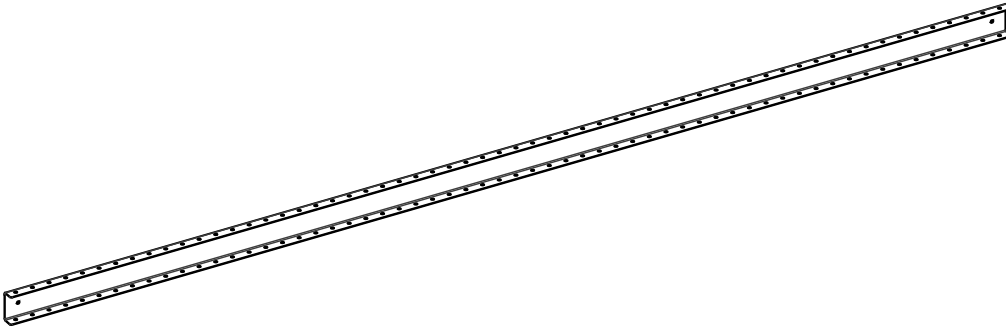

Option: Hardware kit suspension profile – 03702053

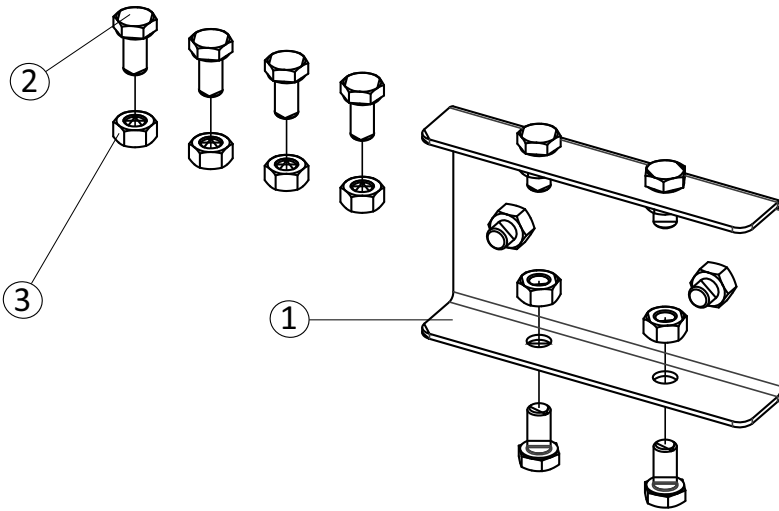

Key	Name	Part Nr.	Qt.
1	SUSP. PROFILE CONNECTOR FA	13018190	1
2	BOLT M8X16 DIN 933 - SP	20200259	10
3	NUT M8 DIN 934 - SP	20200119	10

Power unit

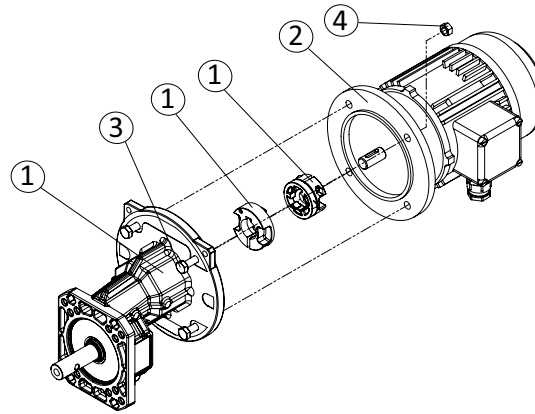

Name		Part Nr.	
SERVICE PARTS		On Demand	
FAN COVER		On Demand	
CONNECTION BOX		On Demand	
CAPACITOR 1-PHASE MOTOR		See table Capacitor	
CABLE RING		On Demand	
Key	Name	Part Nr.	Qt.
	POWER UNIT	0..(See table)	1
1	GEARBOX	1..(See table)	1
2	MOTOR	1..(See table)	1
3	BOLT M8X30-DIN 933-8.8	20100244	4
4	NUT M8 - DIN 934	20200028	4

Capacitor

Capacitor 1 phase motor	
09802330	RUN CAPACITOR 10 μ F
09802338	RUN CAPACITOR 12.5 μ F
09802346	RUN CAPACITOR 18 μ F
09802354	RUN CAPACITOR 20 μ F
09802362	RUN CAPACITOR 25 μ F
09802370	RUN CAPACITOR 30 μ F
09802378	RUN CAPACITOR 45 μ F
09802386	RUN CAPACITOR 50 μ F
09802394	START CAPACITOR 12.5 μ F
09802402	START CAPACITOR 14 μ F
09802410	START CAPACITOR 16 μ F
09802418	START CAPACITOR 20 μ F
09802426	START CAPACITOR 25 μ F
09802442	START CAPACITOR 36-43 μ F
09802450	START CAPACITOR 56-63 μ F
09802458	START CAPACITOR 108-130 μ F

FA	✓	✓	✓	✓	✓	✓	✓	✓	✓	✓
CDS	✗	✓	✓	✓	✓	✗	✗	✓	✓	✗
System	FA-55	FA-75	FA-75/90	FA-90	FA-90	FA-90 HD	FA-90	FA-125	FA-125	FA-125
Gearbox With Key	10106441	13105176	13106505						13702923	
Gearbox With F-Coupling steel				13204132	13203633	13203633	13203641	13702939	13701636	
Gearbox With F-Coupling alu	10111821	13109820	13109828		13204148	13204156	13204164		13702972	13702980
Type Elastic Coupling Set (CS 71-80-90)	CS71 13204180	CS71 13204180	CS71 13204180	CS71 13204180	CS80 13204196	CS90 13204204	CS90 13204204	CS71 13204180	CS80 13204196	CS90 13204204
Motor Shaft	Ø14	Ø14	Ø14	Ø14	Ø19	Ø24	Ø24	Ø14	Ø19	Ø24
Ratio	3.867	7.875	3.867	9.524	2.944	2.944	2.55	12.844	4.75	3.6
Output speed 50 Hz	350	175	350	150	450	450	550	100	290	390
Output speed 60 Hz	420	210	420	180	540	540	660	120	350	470
Construction size	71	71	71	71	80	90	90	71	80	90
Motor speed 50 Hz (RPM)	1,500	1,500	1,500	1,500	1,500	1,500	1,500	1,500	1,500	1,500
Motor speed 60 Hz (RPM)	1,800	1,800	1,800	1,800	1,800	1,800	1,800	1,800	1,800	1,800
Feed capacity kg	520	600	1,300/ 2,400	1,200	3,100	3,100	3,900	1,800	5,400	10,000
Max. Run Time	2 h/day	2 h/day	2 h/day	4 h/day	2 h/day	2 h/day	2 h/day	4 h/day	2/4 h/day	2/4 h/day
3x230/400 V 50 Hz IE1	00107092	03104262	03104310	03202710	03202734	03202798	03202862	03700869	03700885	03701020
Motor IE1	10106482 (0.37 kW)	10106482 (0.37 kW)	13106687 (0.74 kW)	10106482 (0.37 kW)	13203385 (1.1 kW)	14800742 (1.5 kW)	14800742 (1.5 kW)	11901196 (0.55 kW)	13203385 (1.1 kW)	14800742 (1.5 kW)
3x230/400 V 50 Hz IE2					03202742	03202806	03202870		03700893	03701028
Motor IE2					13204212 (1.1 kW IE2)	14802946 (1.5 kW IE2)	14802946 (1.5 kW IE2)		13204212 (1.1 kW IE2)	14802946 (1.5 kW IE2)
3x200/346 V 50 Hz	00107100	03104270	03104318	03202926	03202750	03202814	03202878	03700950	03700901	03701036
Motor	10104487 (0.37 kW)	10104487 (0.37 kW)	13106158 (0.75 kW)	10104487 (0.37 kW)	11024247 (1.1 kW)	14801443 (1.5 kW)	14801443 (1.5 kW)	11901436 (0.55 kW)	11024247 (1.1 kW)	14801443 (1.5 kW)
1x230 V 50 Hz	00107108	03104278	03104326	03202934	03202758	03202822	03202886	03700958	03700909	03701044
Motor	10106656 (0.37 kW)	10106656 (0.37 kW)	13106661 (0.75 kW)	10106656 (0.37 kW)	13203351 (1.3 kW)	14800841 (1.5 kW)	14800841 (1.5 kW)		13203351 (1.3 kW)	14800841 (1.5 kW)
3x220-230/380-400 V 60 Hz	00107116	03104286	03104334	03202942	03202766	03202830	03202894	03700966	03700918	03701052
Motor	19910249 (0.45 kW)	19910249 (0.45 kW)	13106216 (0.9 kW)	19910249 (0.45 kW)	19916030 (1.3 kW)	14801450 (1.8 kW)	14801450 (1.8 kW)	11901444 (0.66 kW)	19916030 (1.32 kW)	14801450 (1.8 kW)
3x200/346 V 60 Hz	00107124	03104294	03104342	03202950	03202774	03202838	03202902	03700972	03700926	03701060
Motor	13105234 (0.45 kW)	13105234 (0.45 kW)	13106166 (0.9 kW)	13105234 (0.45 kW)	13203369 (1.3 kW)	14801476 (1.8 kW)	14801476 (1.8 kW)		13203369 (1.32 kW)	14801476 (1.8 kW)

FA	<input checked="" type="checkbox"/>	<input checked="" type="checkbox"/>	<input checked="" type="checkbox"/>	<input checked="" type="checkbox"/>	<input checked="" type="checkbox"/>	<input checked="" type="checkbox"/>	<input checked="" type="checkbox"/>	<input checked="" type="checkbox"/>	<input checked="" type="checkbox"/>	<input checked="" type="checkbox"/>
CDS	<input checked="" type="checkbox"/>	<input checked="" type="checkbox"/>	<input checked="" type="checkbox"/>	<input checked="" type="checkbox"/>	<input checked="" type="checkbox"/>	<input checked="" type="checkbox"/>	<input checked="" type="checkbox"/>	<input checked="" type="checkbox"/>	<input checked="" type="checkbox"/>	<input checked="" type="checkbox"/>
System	FA-55	FA-75	FA-75/90	FA-90	FA-90	FA-90 HD	FA-90	FA-125	FA-125	FA-125
3x254/440 V 60 Hz	00107132	03104298	03104350	03202958	03202782	03202846	03202910	03700980	03700934	03701068
Motor	19913078 (0.45 kW)	19913078 (0.45 kW)	13106240 (0.9 kW)	19913078 (0.45 kW)	13203377 (1.3 kW)	14801468 (1.8 kW)	14801468 (1.8 kW)		13203377 (1.32 kW)	14801468 (1.8 kW)
1x220 V 60 Hz	00107140	03104302	03104358	03202966	03202790	03202854	03202918	03700988	03700942	03701076
Motor	10110187 (0.55 kW)	10110187 (0.55 kW)	13108618 (0.9 kW)	10110187 (0.55 kW)	13203419 (1.3 kW)	14802227 (1.8 kW)	14802227 (1.8 kW)		13203419 (1.32 kW)	14802227 (1.8 kW)

Motor starter

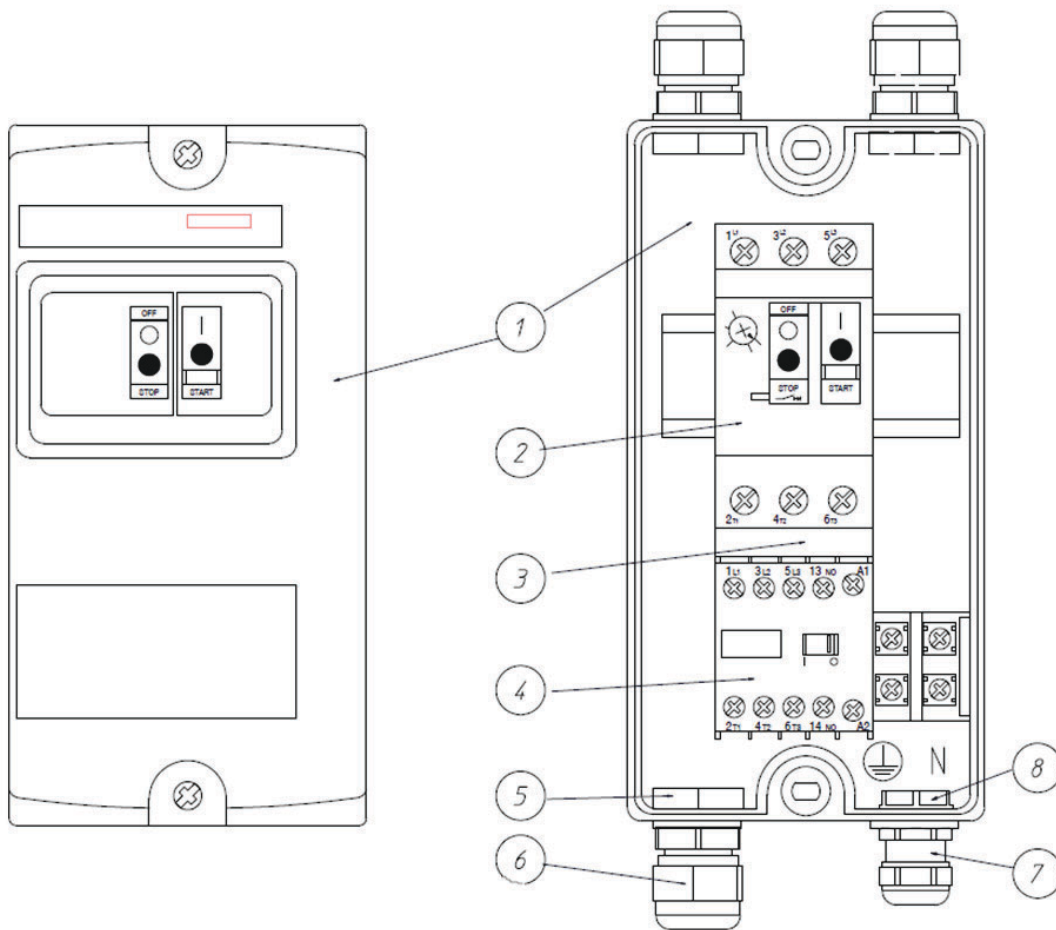

Motor starter used for:					
Motor rating		Supply voltage			
50 Hz	60 Hz	3- PH. 230 V	3- PH. 400 V	1- PH. 230 V	
0.18 kW	0.22 kW	05001233	05001225	05001241	
0.25 kW	0.30 kW	05001233	05001225	05001241	
0.37 kW	0.44 kW	05001241	05001233	05001249	
0.55 kW	0.66 kW	05001249	05001241	05001249	
0.74 kW	0.90 kW	05001249	05001241	05001257	
1.10 kW	1.32 kW	05001257	05001249	05001265	
1.25 kW	1.50 kW	05001257	05001249	05001265	
1.50 kW	1.80 kW	05001265	05001249	05001265	

	Thermal-magnetic motor protection: where used					
Motor starter	05001225	05001233	05001241	05001249	05001257	05001265
Thermal magnetic motor protection	13600861	13900261	13600887	13900279	15004799	15006307
Current	0.63 – 1.00 A	1.00 – 1.60 A	1.60 – 2.50 A	2.50 – 4.00 A	4.00 – 6.30 A	6.00 – 10.00 A

i ATTENTION:

- Always ensure proper earthing.
- For 1 motor control.

Control units

Control unit FA 55 – 03501236

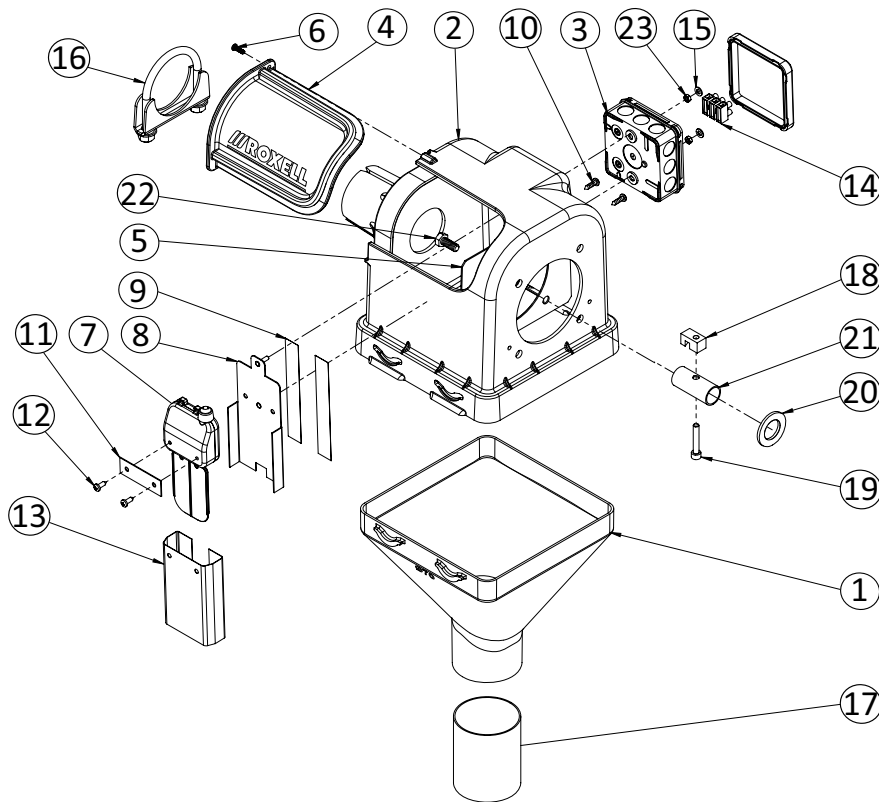

Key	Name	Part Nr.	Qt.
1	DROP FOR DROP TUBE Ø70	13502174	1
2	HOUSING - CONTROL UNIT Ø56	13502166	1
3	HANDY BOX IPW AX4-IP55	15009814	1
4	WINDOW	13000500	1
5	REINFORCEMENT PLATE Ø56-75-90-MOTOR	13109046	1
6	THREAD FORMING SCREW 4X12-A2	12502043	1
7	SAFETY SWITCH ASS'Y	13104567	1
8	SWITCH PLATE WITH PRESS SCREW	13109533	1
9	ADHESIVE TAPE 19X0.23-2SIDE	30800726	2
10	PARCKER SCREW 4.2X16 - DIN 7981	20102331	2
11	SWITCH CONNECTION STRIP	13105259	1
12	PARCKER SCREW 8X1/2"	20100525	2
13	MINIMUM SWITCH SHIELD	10203115	1
14	CLAMP STROKE 27 20 6E/3	10103109	1
15	WASHER 5.3X10X1 - DIN 125 - A2	20102315	2
16	TUBE CLAMP ASSEMBLY Ø67MM	03501293	1
17	INSERT TUBE F/DROP DIA. 70MM	13000534	1
18	DRIVE BLOCK	10100782	1
19	SOCKET CAP SCREW M6X35	20102158	1
20	GALV.WASHER DIA.39x23x3	20103842	1
21	DRIVE TUBE	13500434	1
22	BOLT M8X20-DIN 933-8.8	20200150	4
23	NUT M4	20100681	2

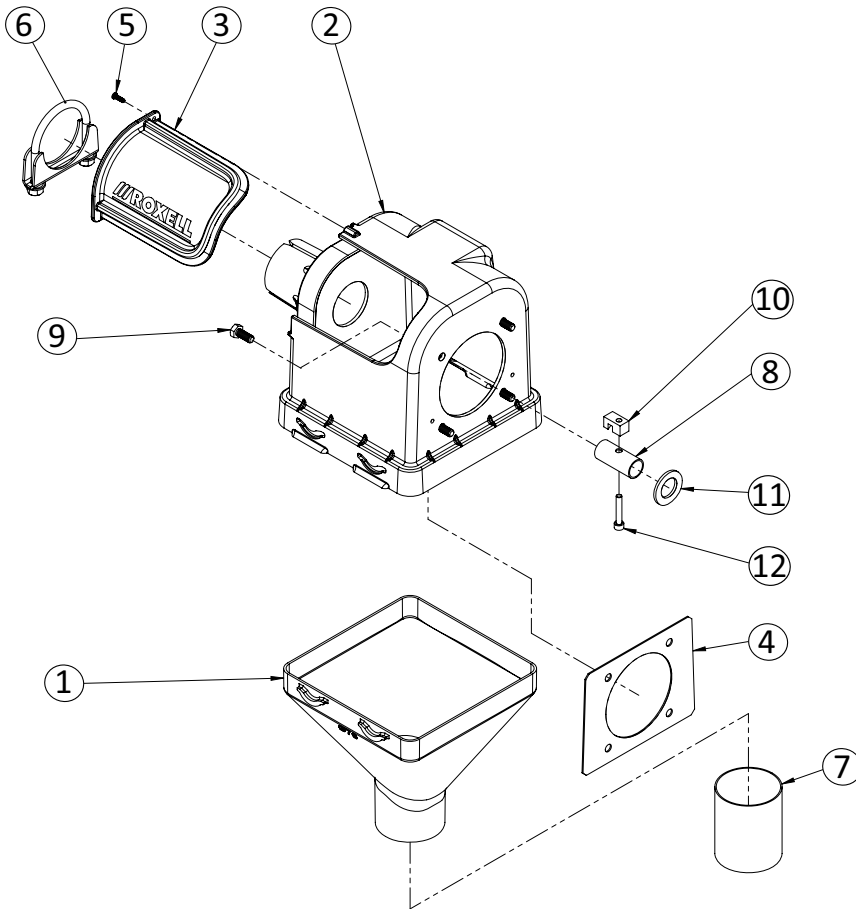
Control unit without safety switch FA 55 – 03501244

Key	Name	Part Nr.	Qt.
1	DROP FOR DROP TUBE Ø70	13502174	1
2	HOUSING - CONTROL UNIT Ø56	13502166	1
3	WINDOW	13000500	1
4	REINFORCEMENT PLATE Ø56-75-90-MOTOR	13109046	1
5	THREAD FORMING SCREW 4X12-A2	12502043	1
6	TUBE CLAMP ASSEMBLY Ø67MM	03501293	1
7	INSERT TUBE F/DROP DIA. 70MM	13000534	1
8	DRIVE TUBE	13500434	1
9	BOLT M8X20-DIN 933-8.8	20200150	4
10	DRIVE BLOCK	10100782	1
11	GALV.WASHER DIA.39x23x3	20103842	1
12	SOCKET CAP SCREW M6X35	20102158	1

Control unit FA 75 – 03103256

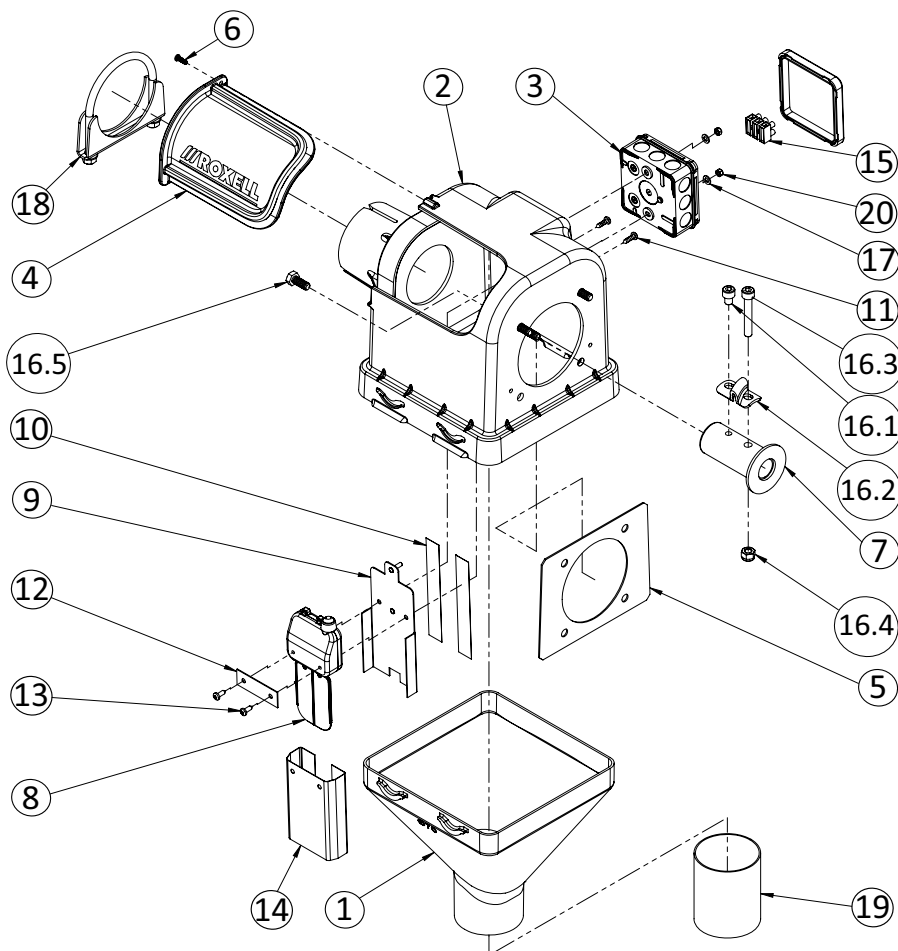

Key	Name	Part Nr.	Qt.
1	DROP FOR DROP TUBE Ø70	13502174	1
2	HOUSING - CONTROL UNIT Ø75	13109038	1
3	HANDY BOX IPW AX4-IP55	15009814	1
4	WINDOW	13000500	1
5	REINFORCEMENT PLATE Ø56-75-90-MOTOR	13109046	1
6	THREAD FORMING SCREW 4X12-A2	12502043	1
7	DRIVER WELDMENT	13105200	1
8	SAFETY SWITCH ASS'Y	13104567	1
9	SWITCH PLATE WITH PRESS SCREW	13109533	1
10	ADHESIVE TAPE 19X0.23-2SIDE	30800726	2
11	PARCKER SCREW 4.2X16 - DIN 7981	20102331	2
12	SWITCH CONNECTION STRIP	13105259	1
13	PARCKER SCREW 8X1/2"	20100525	2
14	MINIMUM SWITCH SHIELD	10203115	1
15	CLAMP STROKE 27 20 6E/3	10103109	1
16	HARDWARE KIT CU FA 75	13109558	2
16.1	SOCKET CAP SCREW M8x10-DIN 912	20102778	1
16.2	ANCHOR CLAMP	13104575	1
16.3	SOCKET CAP SCREW M8X50-DIN 912	20102786	1
16.4	LOCKNUT M8 - DIN 985	20100418	1
16.5	BOLT M8X20-DIN 933-8.8	20200150	4
17	WASHER 5.3X10X1 - DIN 125 - A2	20200150	2
18	TUBE CLAMP ASSEMBLY Ø86MM	03103306	1
19	INSERT TUBE FOR DROP Ø70MM	13000534	1
20	LOCKNUT M4-DIN 985	20100657	1

Control unit FA 90 / FA 75 – 03202553

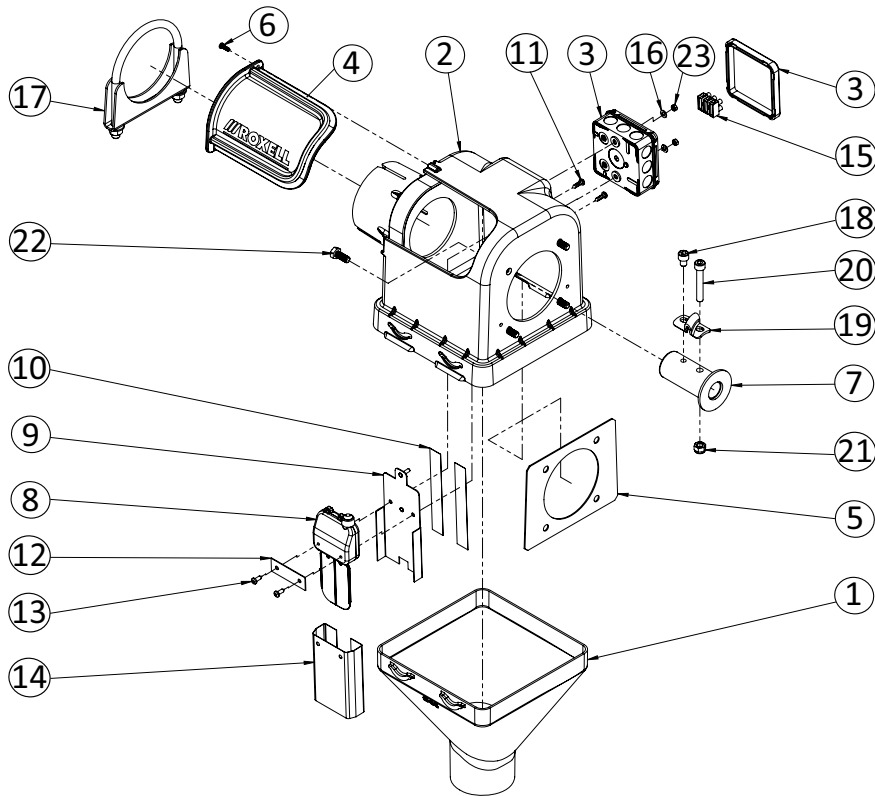

Key	Name	Part Nr.	Qt.
1	DROP FOR DROP TUBE Ø85	13203815	1
2	HOUSING - CONTROL UNIT Ø89	13203807	1
3	HANDY BOX IPW AX4-IP55	15009814	1
4	WINDOW	13000500	1
5	REINFORCEMENT PLATE Ø56-75-90-MOTOR	13109046	1
6	THREAD FORMING SCREW 4X12-A2	12502043	1
7	DRIVER WELDMENT	13105200	1
8	SAFETY SWITCH ASS'Y	13104567	1
9	SWITCH PLATE WITH PRESS SCREW	13109533	1
10	ADHESIVE TAPE 19X0.23-2SIDE	30800726	2
11	PARCKER SCREW 4.2X16 - DIN 7981	20102331	2
12	SWITCH CONNECTION STRIP	13105259	1
13	PARCKER SCREW 8X1/2"	20100525	2
14	MINIMUM SWITCH SHIELD	10203115	1
15	CLAMP STROKE 27 20 6E/3	10103109	1
16	WASHER 5.3X10X1 - DIN 125 - A2	20102315	2
17	TUBE CLAMP ASSEMBLY Ø100MM	03202561	1
18	SOCKET CAP SCREW M8X10 - DIN 912	20102778	1
19	ANCHOR CLAMP	13104575	1
20	SOCKET CAP SCREW M8X50-DIN 912	20102786	1
21	LOCKNUT M8 - DIN 985	20100418	1
22	BOLT M8X20 - DIN 933-8.8	20200150	4

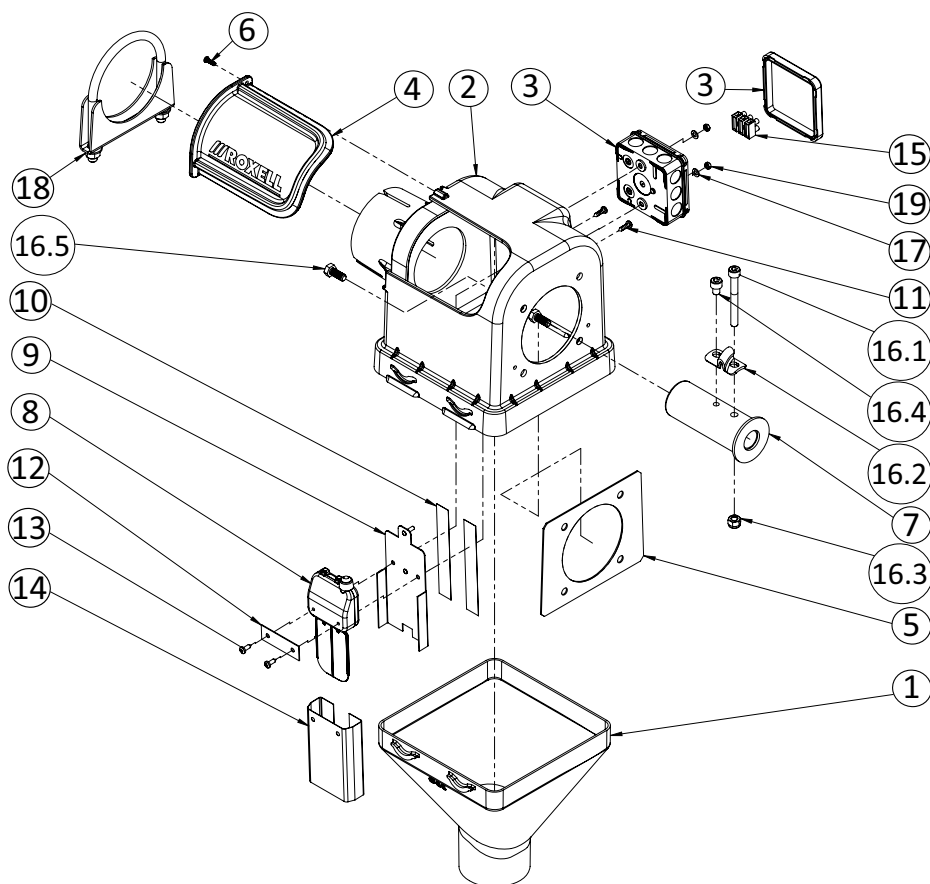
Control unit FA 90 – 03202496

Key	Name	Part Nr.	Qt.
1	DROP FOR DROP TUBE Ø85	13203815	1
2	HOUSING - CONTROL UNIT Ø89	13203807	1
3	HANDY BOX IPW AX4-IP55	15009814	1
4	WINDOW	13000500	1
5	REINFORCEMENT PLATE Ø56-75-90-MOTOR	13109046	1
6	THREAD FORMING SCREW 4X12-A2	12502043	1
7	DRIVER WELDMENT	13201561	1
8	SAFETY SWITCH ASS'Y	13104567	1
9	SWITCH PLATE WITH PRESS SCREW	13109533	1
10	ADHESIVE TAPE 19X0.23-2SIDE	30800726	2
11	PARCKER SCREW 4.2X16 - DIN 7981	20102331	2
12	SWITCH CONNECTION STRIP	13105259	1
13	PARCKER SCREW 8X1/2"	20100525	2
14	MINIMUM SWITCH SHIELD	10203115	1
15	CLAMP STROKE 27 20 6E/3	10103109	1
16	HARDWARE KIT CU FA90	13203849	1
16.1	SOCKET CAP SCREW M8X70 - DIN 912	20101986	1
16.2	ANCHOR CLAMP	13104575	1
16.3	LOCKNUT M8 - DIN 985	20100418	1
16.4	SOCKET CAP SCREW M8X10 - DIN 912	20102778	1
16.5	BOLT M8X20 - DIN 933-8.8	20200150	4
17	WASHER 5.3X10X1 - DIN 125 - A2	20102315	2
18	TUBE CLAMP ASSEMBLY Ø100MM	03202561	1

Upper boots

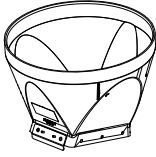
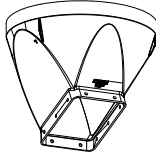
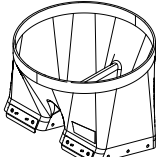
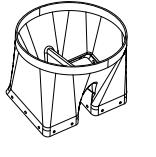
<p>Upper boot 0° - 03000579</p> 	<p>Upper boot 15° PE - black - 03000577</p> 
<p>Quadruple boot 0° - 03102847</p> 	<p>Quadruple boot - 03001243</p> 

Cover assembly for upper boot - 03001195

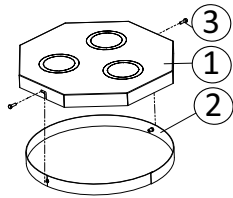

Key	Name	Part Nr.	Qt.
1	COVER FOR UPPER BOOT	13703012	1
2	RING FOR COVER UPPER BOOT	13703020	1
3	BOLT M6 X 20 - DIN 933 - 8.8	20100186	2

Transfer plate assembly - PE - black - 03000585

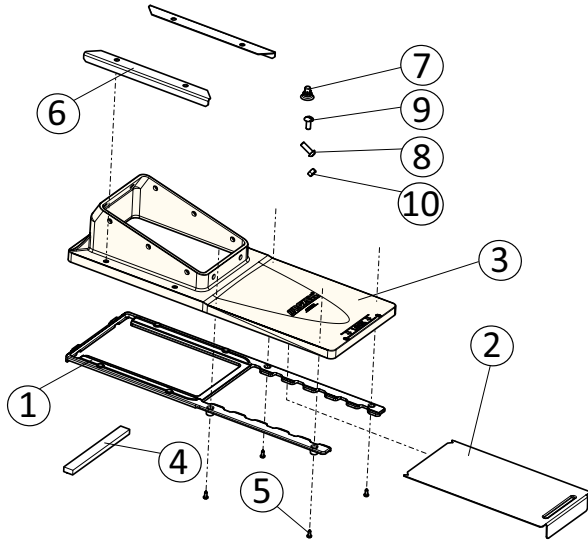

Key	Name	Part Nr.	Qt.
1	SEALING PLATE	13000575	1
2	SLIDE VALVE	13000583	1
3	TRANSFER PLATE HOUSING	13000567	1
4	GASKET 20x10	30800064	1
5	PARCKERSCREWD.4.2X13-D7981-A2	20200267	4
*6	REINFORCEMENT PROFILE	13000591	2
*7	RUBBER CAP M 8	16103699	18
*8	TRUSS HEAD BOLT M8X20 - SP	20200176	8
*9	FLAT ROUND HEAD SCREW M8X25	20109708	10
*10	NUT M8 - PA6 BLACK	20109781	18
*	HARDWARE/PROFILES KIT	13000971	1

Intake boots

Closing plate kit for intake boot - 13000146

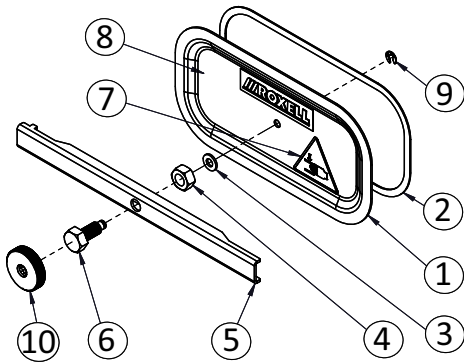

Key	Name	Part Nr.	Qt.
1	CLOSING PLATE	13107776	1
2	GASKET 15X2	30800874	1
3	FIBER RING	20104287	1
4	NUT M10 - DIN 934	20100277	1
5	CLOSING PROFILE	13107768	1
6	CLOSING BOLT - BRASS SMAL	13108154	1
7	DECAL - HANDS WARNING	13106596	1
8	ROXELL DECAL - 160X40	10101129	1
9	E-RING Ø5-DIN 6799-A2 S.S	20102018	1
10	KNURLED KNOB	13107842	1

Feed intake boot FA 55 - 03501335

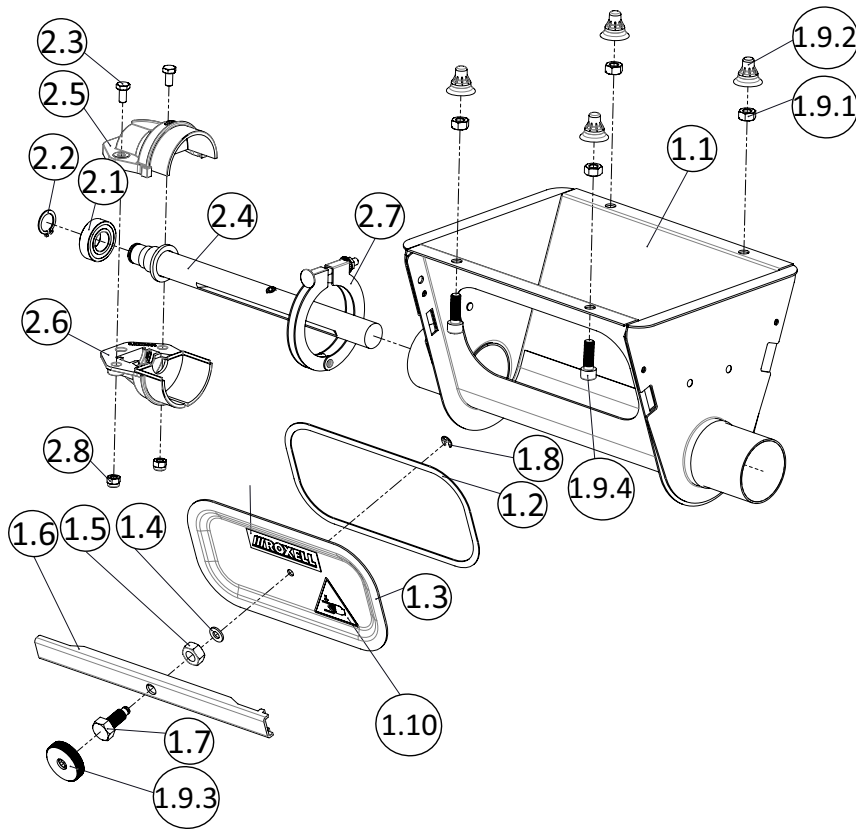

Key	Name	Part Nr.	Qt.
1	INTAKE BOOT & CLOSING PLATE	13501630	1
1.1	BOOT BODY WELDMENT FA 55	13501515	1
1.2	GASKET 15X2	30800874	1
1.3	CLOSING PLATE	13107776	1
1.4	FIBER RING	20104287	1
1.5	NUT M10 - DIN 934	20100277	1
1.6	CLOSING PROFILE	13107768	1
1.7	CLOSING BOLT - BRASS SMAL	13108154	1
1.8	E-RING Ø5-DIN 6799-A2 S.S	20102018	1
1.9	HARDWARE KIT	13108055	1
1.9.1	NUT M8 DIN 934 - SP	20200119	4
1.9.2	SEAL CAP M8	16103699	4
1.9.3	KNURLED KNOB	13107842	1
1.9.4	SOCKET CAP SCREW M8X25 - DIN 912	20101978	4
1.10	DECAL ISO7010-W024 WIDTH=50MM	15011878	1
1.11	DECAL - ROXELL 73x18	10102697	1
2	ANCHOR & BEARING ASS'Y FA55	13502299	1
2.1	BEARING 17X35X10 - 6003 LLU	13201066	1
2.2	SEEGER RING Ø17X1	20101333	1
2.3	BOLT M6X12 - DIN 933-8.8	20100160	2
2.4	SHAFT FA 55 WELDMENT Ø22 - LG=274MM	13502331	1
2.5	BEARING HOLDER CAP UP - Ø56	13502265	1
2.6	BEARING HOLDER CAP DOWN - Ø56	13502273	1
2.7	TUBE CLAMP ASS'Y Ø63	13601661	1
2.8	LOCKNUT M6 - DIN 985	20100400	2

Feed intake boot FA 75 - 03103850

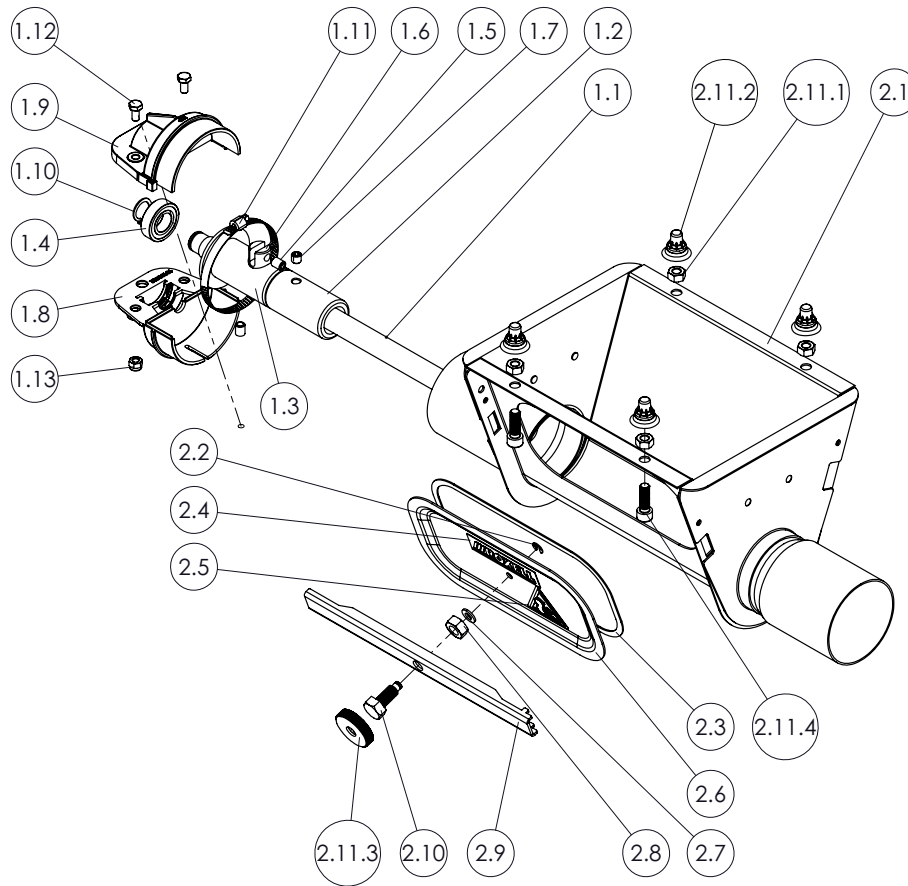

Key	Name	Part Nr.	Qt.
1	ANCHOR & BEARING ASS'Y FA75	13109681	1
1.1	ANCHOR & BEARING SHAFT FA75-90	13109731	1
1.2	RESTRICTOR Ø36	13105838	1
1.3	ANCHOR TUBE WELDMENT Ø36	13105853	1
1.4	BEARING 17X35X10 - 6003 LLU	13201066	1
1.5	SET SCREW M8X10 - DIN 916	20100434	2
1.6	CLAMP PIN	13100482	1
1.7	SET SCREW M8X8-DIN 916	20101697	1
1.8	BEARING HOLDER CAP DOWN - Ø75	13109632	1
1.9	BEARING HOLDER CAP UP - Ø75	13109624	1
1.10	SEGER RING Ø17X1	20101333	1
1.11	HOSE CLAMP ASSEMBLY Ø70-90	03100658	1
1.12	BOLT M6X12 - DIN 933-8.8	20100160	2
1.13	LOCKNUT M6 - DIN 985	20100400	2
2	INTAKE BOOT & CLOSING PLATE	13108022	1
2.1	BOOT BODY WELDMENT FA 75	13108030	1
2.2	E-RING Ø5-DIN 6799-A2 S.S	20102018	1
2.3	GASKET 15X2	30800874	1
2.4	DECAL - ROXELL 73x18	10102697	1
2.5	DECAL - HANDS WARNING	13106596	1
2.6	CLOSING PLATE	13107776	1
2.7	FIBER RING	20104287	1
2.8	NUT M10 - DIN 934	20100277	1
2.9	CLOSING PROFILE	13107768	1
2.10	CLOSING BOLT - BRASS SMAL	13108154	1
2.11	HARDWARE KIT	13108055	1
2.11.1	NUT M8 DIN 934 - SP	20200119	4

Key	Name	Part Nr.	Qt.
2.11.2	SEAL CAP M8	16103699	4
2.11.3	KNURLED KNOB	13107842	1
2.11.4	SOCKET CAP SCREW M8X25 - DIN 912	20101978	4

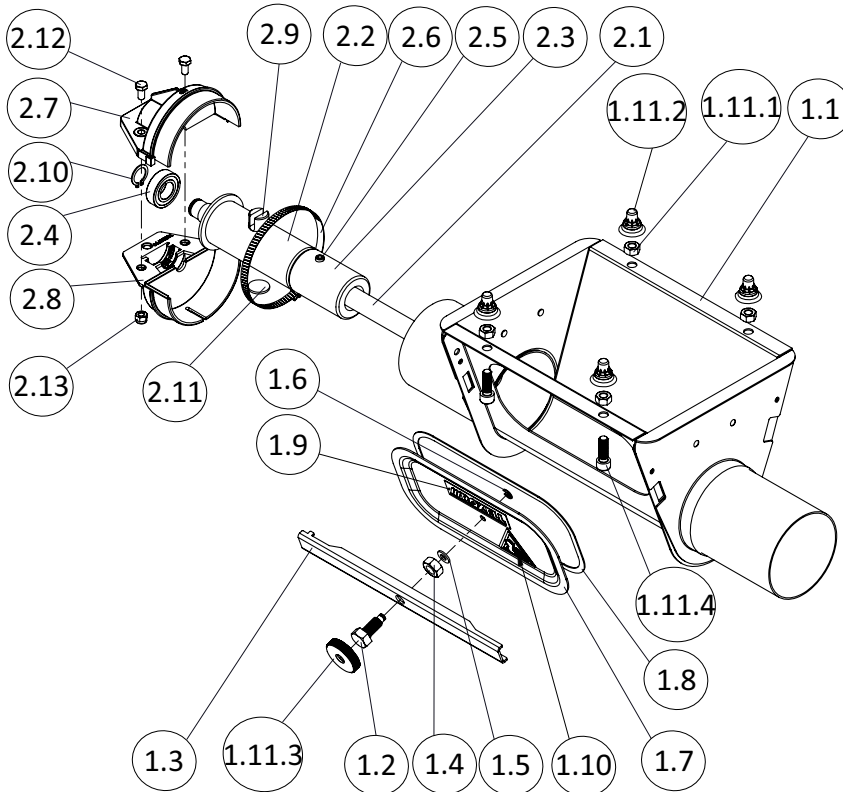
Feed intake boot FA 90 - 03202629

Key	Name	Part Nr.	Qt.
1	INTAKE BOOT & CLOSING PLATE FA90	13202957	1
1.1	BOOT BODY WELDMENT FA 90	13202965	1
1.2	CLOSING BOLT - BRASS SMAL	13108154	1
1.3	CLOSING PROFILE	13107768	1
1.4	NUT M10 - DIN 934	20100277	1
1.5	FIBER RING	20104287	1
1.6	E-RING Ø5-DIN 6799-A2 S.S	20102018	1
1.7	CLOSING PLATE	13107776	1
1.8	GASKET 15X2	30800874	1
1.9	DECAL - ROXELL 73x18	10102697	1
1.10	DECAL - HANDS WARNING	13106596	1
1.11	HARDWARE KIT	13108055	1
1.11.1	NUT M8 DIN 934 - SP	20200119	4
1.11.2	SEAL CAP M8	16103699	4
1.11.3	KNURLED KNOB	13107842	1
1.11.4	SOCKET CAP SCREW M8X25 - DIN 912	20101978	4
2	ANCHOR & BEARING ASS'Y FA90	13204011	1
2.1	ANCHOR & BEARING SHAFT FA75-90	13109731	1
2.2	ANCHOR TUBE WELDMENT Ø44	13201769	1
2.3	RESTRICTOR Ø44	13201744	1
2.4	BEARING 17X35X10 - 6003 LLU	13201066	1
2.5	SET SCREW M8X10 - DIN 916	20100434	3
2.6	HOSE CLAMP Ø80 - 100MM	03200250	1
2.7	BEARING HOLDER CAP UP - Ø90	13203781	1
2.8	BEARING HOLDER CAP DOWN - Ø90	13203799	1
2.9	CLAMP PIN	13100482	1

Key	Name	Part Nr.	Qt.
2.10	SEEGER RING Ø17X1	20101333	1
2.11	SPACER	13200134	2
2.12	BOLT M6X12 - DIN 933-8.8	20100160	2
2.13	LOCKNUT M6 - DIN 985	20100400	2

Feed intake boot FA 75 / FA 90 - 03202694

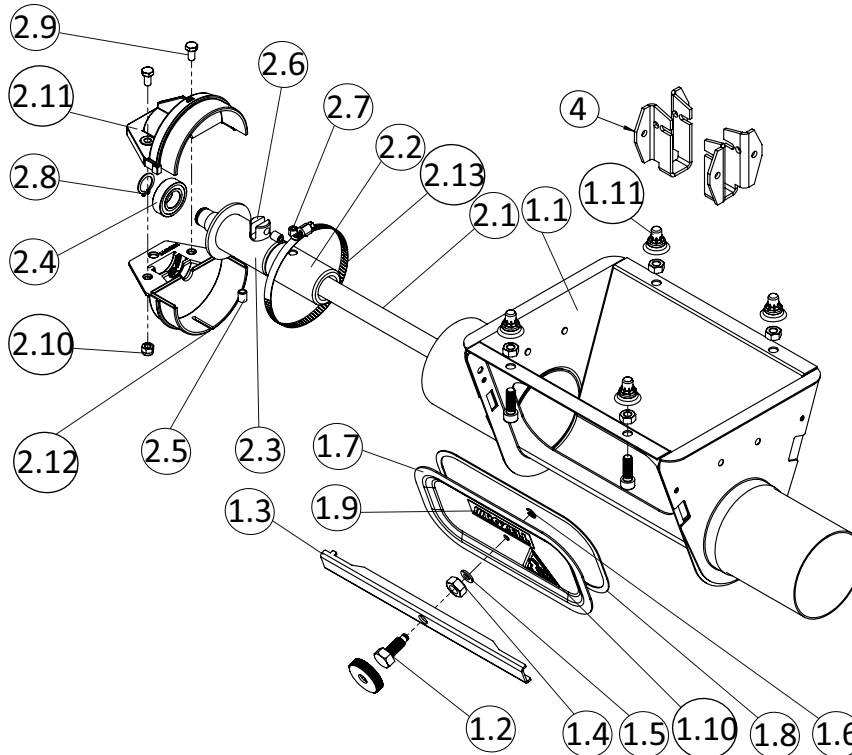

Key	Name	Part Nr.	Qt.
1	INTAKE BOOT & CLOSING PLATE FA90	13202957	1
1.1	BOOT BODY WELDMENT FA 90	13202965	1
1.2	CLOSING BOLT - BRASS SMAL	13108154	1
1.3	CLOSING PROFILE	13107768	1
1.4	NUT M10-DIN 934	20100277	1
1.5	FIBER RING	20104287	1
1.6	E-RING DIA.5-DIN 6799-S.S	20102018	1
1.7	CLOSING PLATE	13107776	1
1.8	GASKET 15 x 2	30800874	1
1.9	DECAL - ROXELL 73x18	10102697	1
1.10	DECAL - HANDS WARNING	13106596	1
1.11	HARDWARE KIT	13108055	1
2	ANCHOR & BEARING ASS'Y FA 90-75	13204029	1
2.1	ANCHOR&BEARING SHAFT FA75-90	13109731	1
2.2	RESTRICTOR DIA.36	13105838	1
2.3	ANCHOR TUBE WELDMENT DIA.36	13105853	1
2.4	BEARING 17 X 35 X 10 - 6003 LLU	13201066	1
2.5	SET SCREW M8 x 10 - DIN 916	20100434	2
2.6	CLAMP PIN	13100482	1
2.7	SET SCREW M8X8-DIN 916	20101697	1
2.8	SEEGER RING DIA. 17 X 1	20101333	1
2.9	BOLT M6 X 12 - DIN 933-8.8	20100160	2
2.10	LOCKNUT M6 - DIN 985	20100400	2
2.11	BEARING HOLDER CAP UP - DIA.90	13203781	1

Key	Name	Part Nr.	Qt.
2.12	BEARING HOLDER CAP DOWN-DIA.90	13203799	1
2.13	HOSE CLAMP \varnothing 80-100	03200250	1
3	THUMPER HOLDER	13109844	2

Feed intake boot FA 125 - 03702141

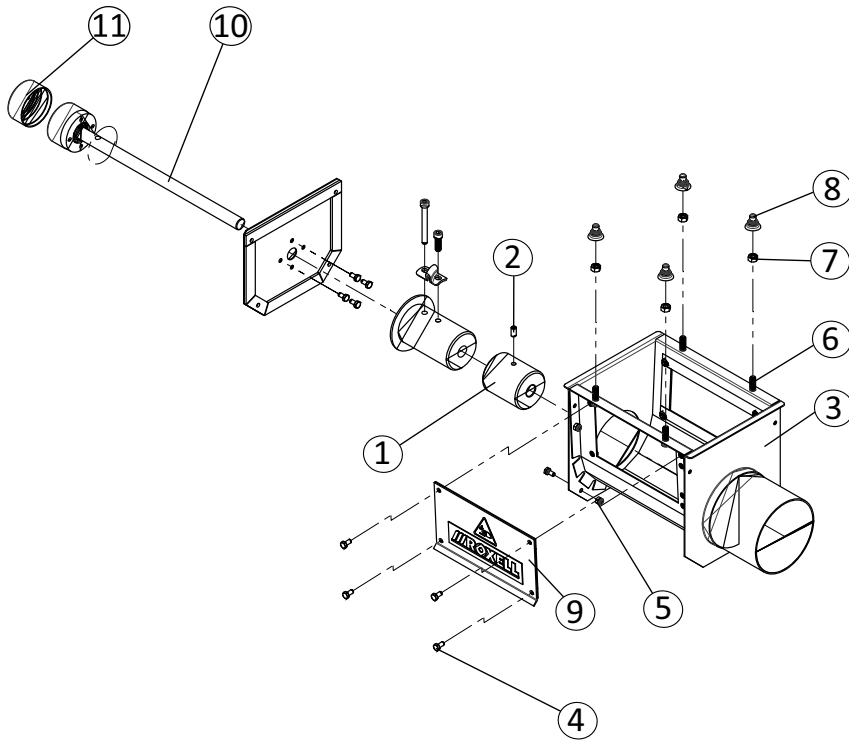

Key	Name	Part Nr.	Qt.
1	RESTRICTOR FA125 \varnothing 65	13704212	1
2	SET SCREW M8 x 15 - DIN 916	20100442	1
3	BOOT BODY WELDMENT	13701081	1
4	BOLT M6X12 - DIN 933-8.8	20100160	12
5	LOCKNUT M6 - DIN 985	20100400	4
6	SOCKET CAP SCREW M8 X 25 - DIN 912	20101978	4
7	NUT M8 DIN 934 - SP	20200119	4
8	RUBBER CAP M 8	16103699	4
9	CLOSING PLATE ASS'Y	13102629	2
10	ANCHOR + BEARING ASS'Y FA125	13704236	1
11	CAP DIA. 63.5	13701131	1

Double intake boot FA 55 - 03501343

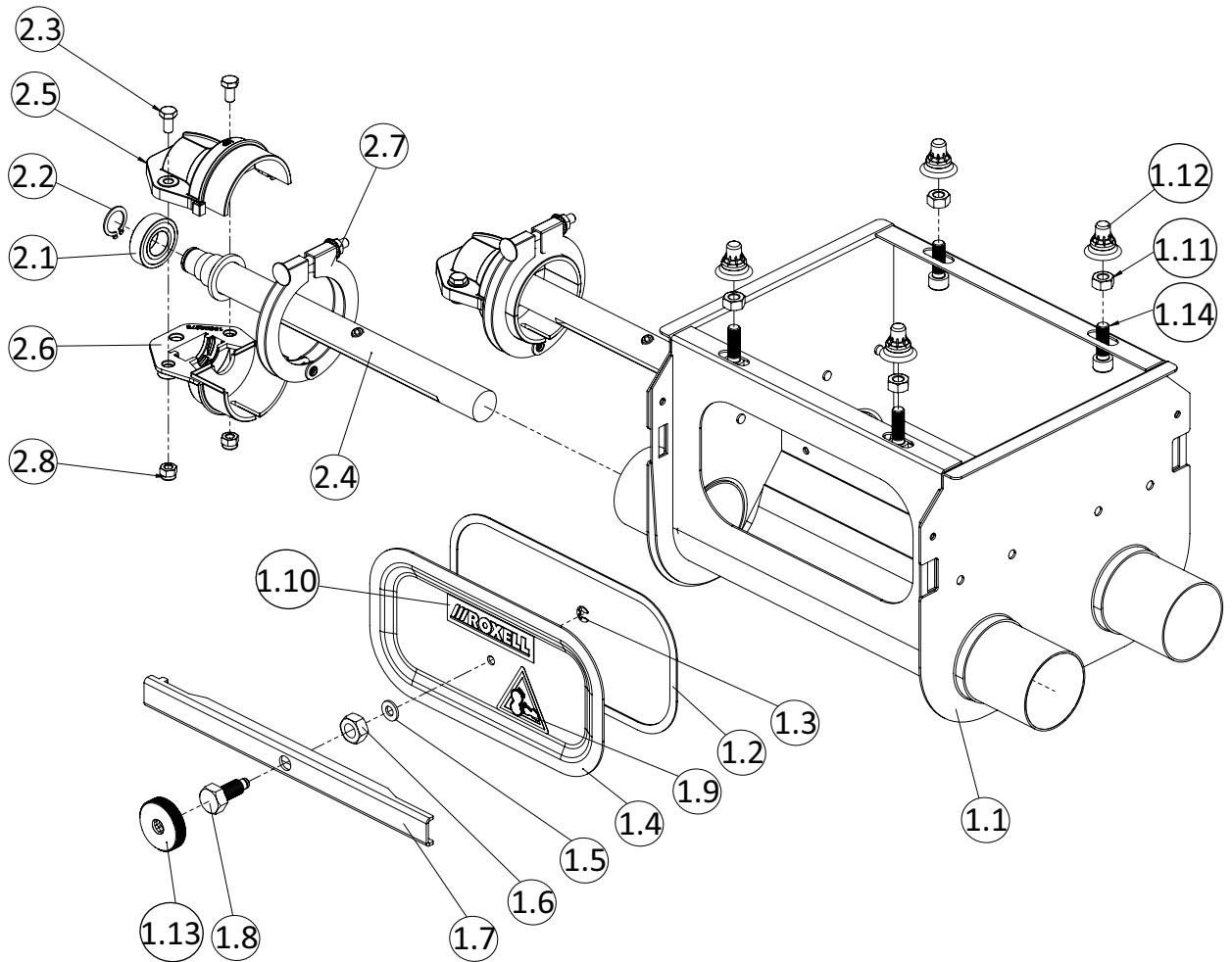

Key	Name	Part Nr.	Qt.
1	DOUBLE INTAKE BOOT & CLOSING PLATE FA55	13501655	1
1.1	DOUBLE BOOT WELDMENT WELDMENT FA55	13501663	1
1.2	GASKET 15X2	30800874	1
1.3	E-RING Ø5-DIN 6799-A2 S.S	20102018	1
1.4	CLOSING PLATE	13107776	1
1.5	FIBER RING	20104287	1
1.6	NUT M10 - DIN 934	20100277	1
1.7	CLOSING PROFILE	13107768	1
1.8	CLOSING BOLT - BRASS SMAL	13108154	1
1.9	DECAL - HANDS WARNING	10101129	1
1.10	DECAL - ROXELL 73x18	10102697	1
1.11.	NUT M8 DIN 934 - SP	20200119	4
1.12	SEAL CAP M8	16103699	4
1.13	KNURLED KNOB	13107842	1
1.14	SOCKET CAP SCREW M8X25 - DIN 912	20101978	4
2	ANCHOR & BEARING ASS'Y FA55	13502299	2
2.1	BEARING 17X35X10 - 6003 LLU	13201066	1
2.2	SEEGER RING Ø17X1	20101333	1
2.3	BOLT M6X12 - DIN 933-8.8	20100160	2
2.4	SHAFT FA 55 WELDMENT Ø22 - LG=274MM	13502331	1
2.5	BEARING HOLDER CAP UP - Ø56	13502265	1
2.6	BEARING HOLDER CAP DOWN - Ø56	13502273	1
2.7	TUBE CLAMP ASS'Y Ø63	13601661	1
2.8	LOCKNUT M6 - DIN 985	20100400	1

Double intake boot FA 75 - 03103868

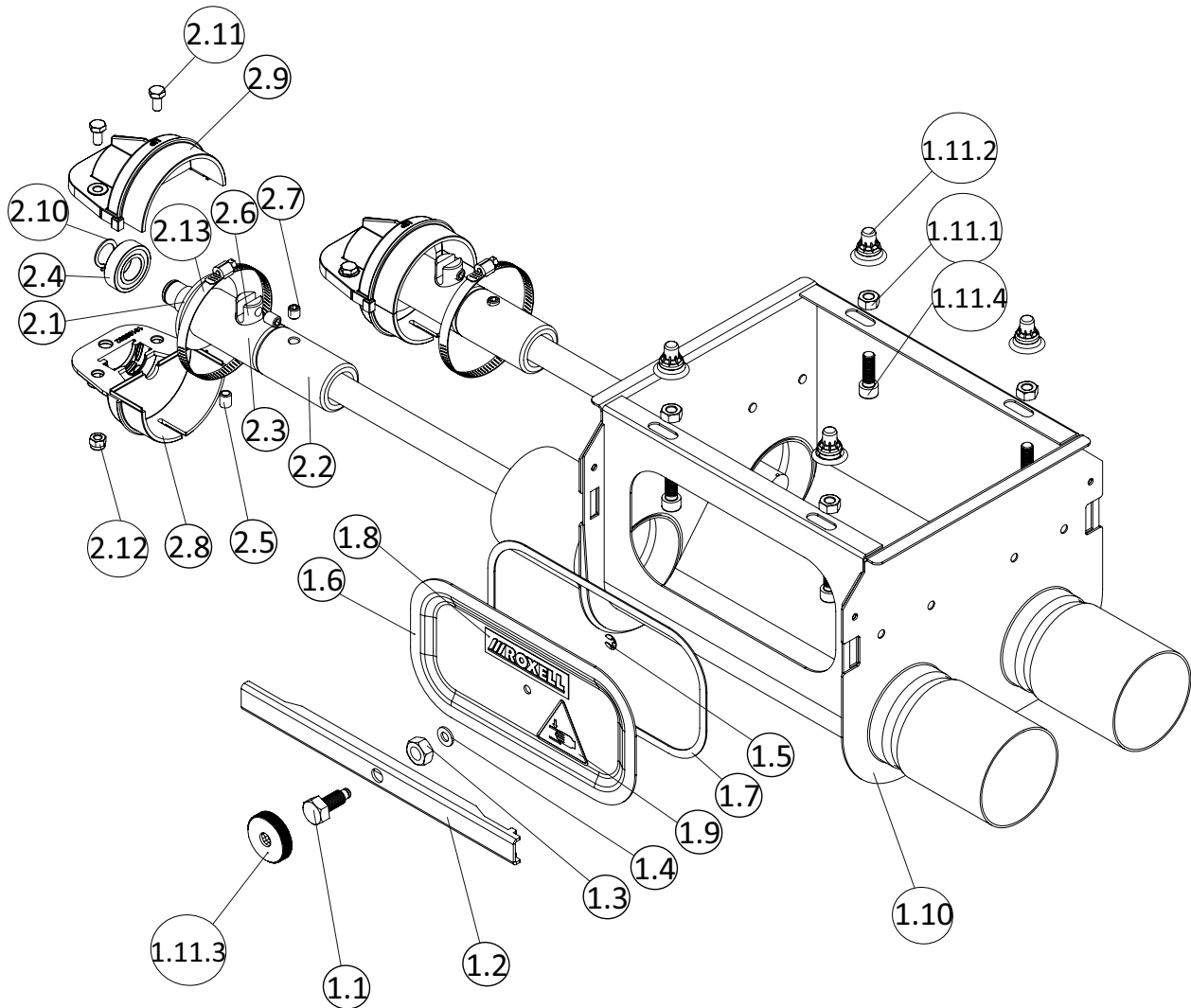

Key	Name	Part Nr.	Qt.
1	DOUBLE INTAKE BOOT & CLOSING PLATE FA75	13108071	1
1.1	CLOSING BOLT - BRASS SMAL	13108154	1
1.2	CLOSING PROFILE	13107768	1
1.3	NUT M10 - DIN 934	20100277	1
1.4	FIBER RING	20104287	1
1.5	E-RING Ø5-DIN 6799-A2 S.S	20102018	1
1.6	CLOSING PLATE	13107776	1
1.7	GASKET 15X2	30800874	1
1.8	DECAL - ROXELL 73x18	10102697	1
1.9	DECAL - HANDS WARNING	13106596	1
1.10	DOUBLE BOOT WELDMENT FA 75	13108063	1
1.11	HARDWARE KIT	13108055	1
1.11.1	NUT M8 DIN 934 - SP	20200119	4
1.11.2	SEAL CAP M8	16103699	4
1.11.3	KNURLED KNOB	13107842	1
1.11.4	SOCKET CAP SCREW M8X25 - DIN 912	20101978	4
2	ANCHOR & BEARING ASS'Y FA75	13109681	2
2.1	ANCHOR & BEARING SHAFT FA75-90	13109731	1
2.2	RESTRICTOR Ø36	13105838	1
2.3	ANCHOR TUBE WELDMENT Ø36	13105853	1
2.4	BEARING 17X35X10 - 6003 LLU	13201066	1
2.5	SET SCREW M8X10 - DIN 916	20100434	2

Key	Name	Part Nr.	Qt.
2.6	CLAMP PIN	13100482	1
2.7	SET SCREW M8X8-DIN 916	20101697	1
2.8	BEARING HOLDER CAP DOWN - Ø75	13109632	1
2.9	BEARING HOLDER CAP UP - Ø75	13109624	1
2.10	SEEGER RING Ø17X1	20101333	1
2.11	BOLT M6X12 - DIN 933-8.8	20100160	2
2.12	LOCKNUT M6 - DIN 985	20100400	2
2.13	HOSE CLAMP ASSEMBLY Ø70-90	03100658	1

Double intake boot FA 90 - 03202637

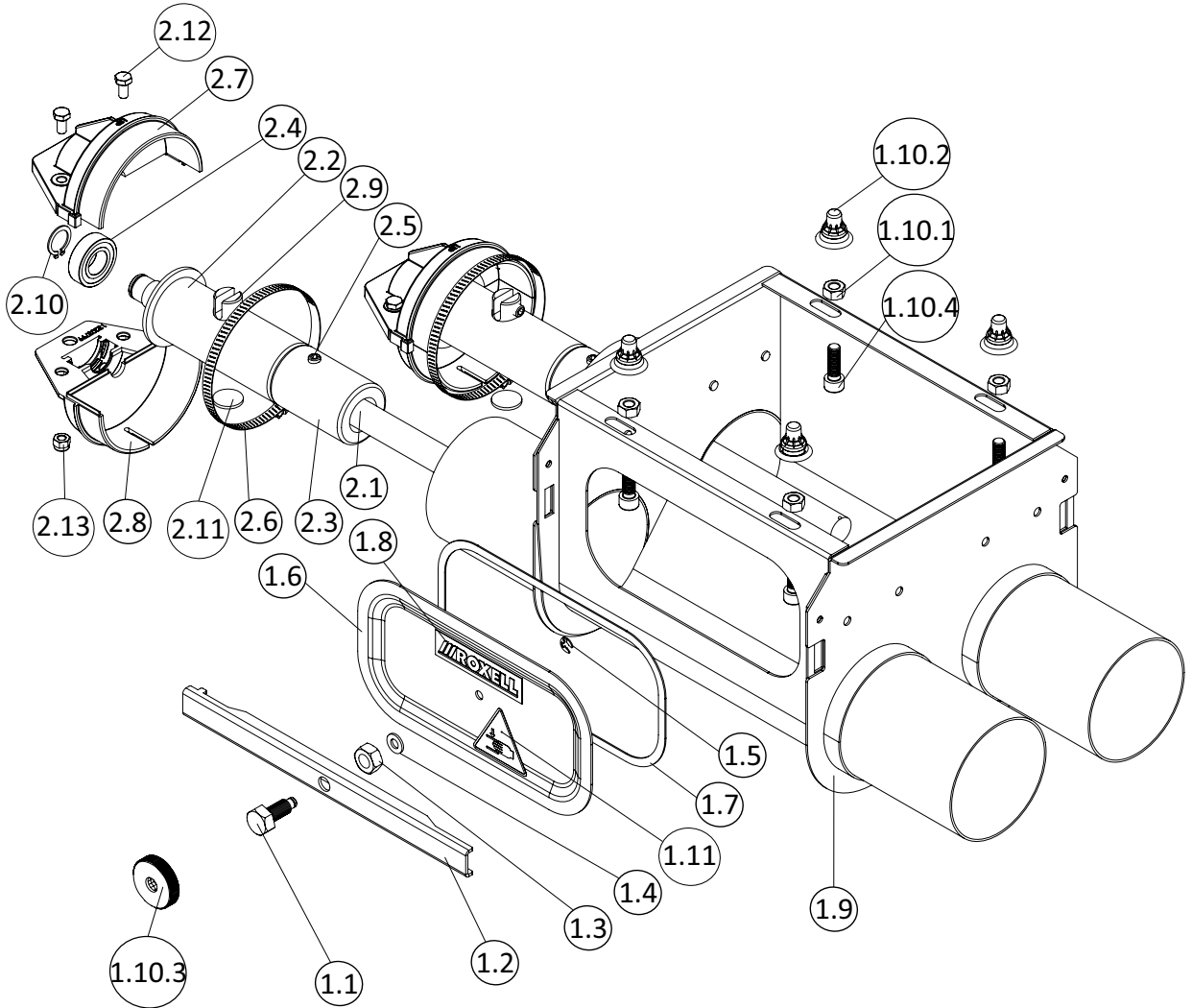

Key	Name	Part Nr.	Qt.
1	DOUBLE INTAKE BOOT & CLOSING PLATE FA90	13203005	1
1.1	CLOSING BOLT - BRASS SMAL	13108154	1
1.2	CLOSING PROFILE	13107768	1
1.3	NUT M10 - DIN 934	20100277	1
1.4	FIBER RING	20104287	1
1.5	E-RING Ø5-DIN 6799-A2 S.S	20102018	1
1.6	CLOSING PLATE	13107776	1
1.7	GASKET 15X2	30800874	1
1.8	DECAL - ROXELL 73x18	10102697	1
1.9	DOUBLE BOOT WELDMENT FA 90	13203013	1
1.10	HARDWARE KIT	13108055	1
1.10.1	NUT M8 DIN 934 - SP	20200119	4

Key	Name	Part Nr.	Qt.
1.10.2	SEAL CAP M8	16103699	4
1.10.3	KNURLED KNOB	13107842	1
1.10.4	SOCKET CAP SCREW M8X25 - DIN 912	20101978	4
2	ANCHOR & BEARING ASS'Y FA90	13204011	2
2.1	ANCHOR & BEARING SHAFT FA75-90	13109731	1
2.2	ANCHOR TUBE WELDMENT Ø44	13201769	1
2.3	RESTRICTOR Ø44	13201744	1
2.4	BEARING 17X35X10 - 6003 LLU	13201066	1
2.5	SET SCREW M8X10 - DIN 916	20100434	3
2.6	HOSE CLAMP Ø80 - 100MM	03200250	1
2.7	BEARING HOLDER CAP UP - Ø90	13203781	1
2.8	BEARING HOLDER CAP DOWN - Ø90	13203799	1
2.9	CLAMP PIN	13100482	1
2.10	SEEGER RING Ø17X1	20101333	1
2.11	SPACER	13200134	2
2.12	BOLT M6X12 - DIN 933-8.8	20100160	2
2.13	LOCKNUT M6 - DIN 985	20100400	2

Double intake boot FA55 / FA 75 - 03000882

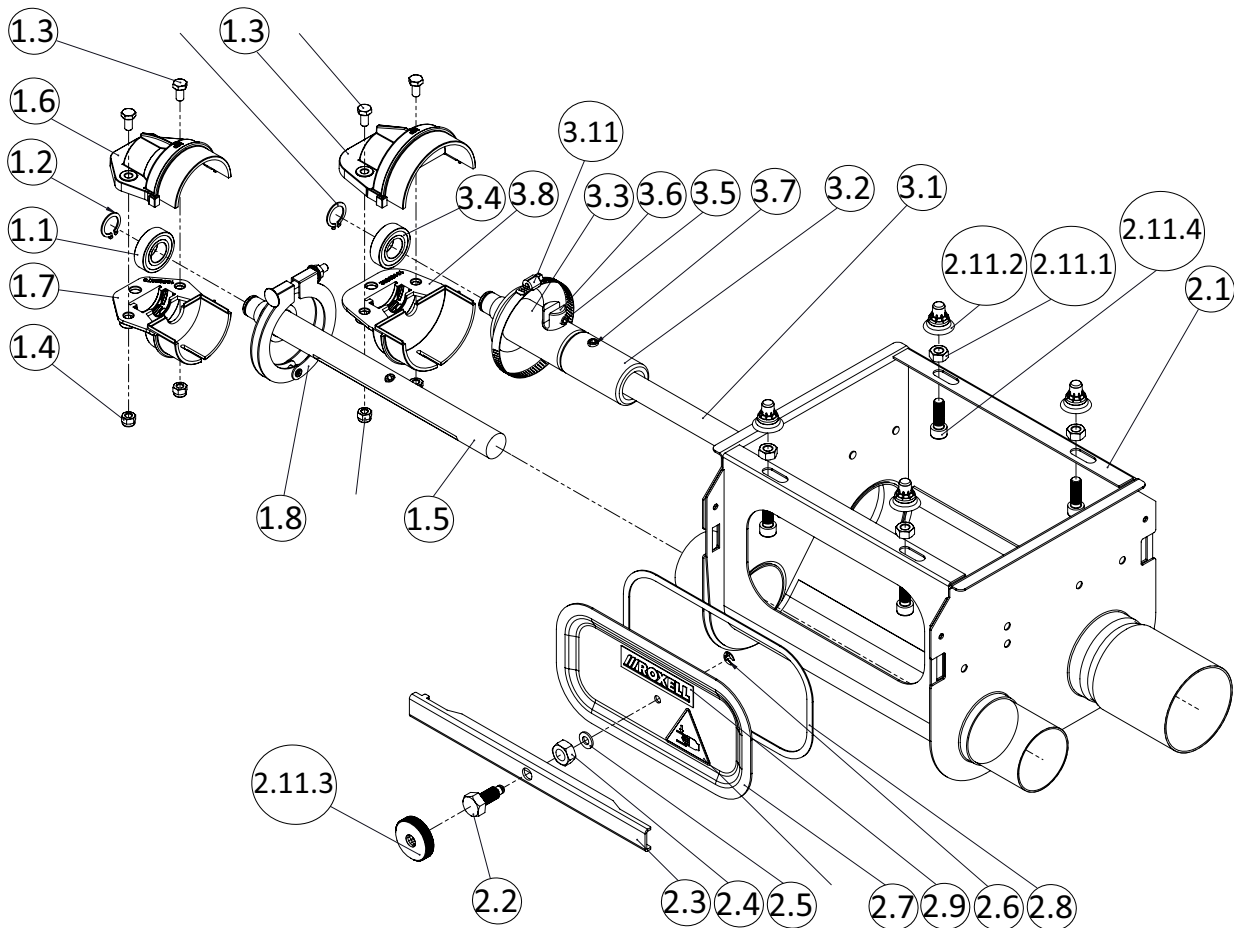

Key	Name	Part Nr.	Qt.
1	ANCHOR & BEARING ASS'Y FA55	13502299	1
1.1	BEARING 17X35X10 - 6003 LLU	13201066	1
1.2	SEEGER RING Ø17X1	20101333	1
1.3	BOLT M6X12 - DIN 933-8.8	20100160	2
1.4	LOCKNUT M6 - DIN 985	20100400	2
1.5	SHAFT FA 55 WELDMENT Ø22 - LG=274MM	13502331	1
1.6	BEARING HOLDER CAP UP - Ø56	13502265	1

Key	Name	Part Nr.	Qt.
1.7	BEARING HOLDER CAP DOWN - Ø56	13502273	1
1.8	TUBE CLAMP ASS'Y Ø63	13601661	1
2	DOUBLE BOOT&CLOS.PL.FA75-FA55	13000955	1
2.1	DOUBLE BOOT WELDM. FA75-FA55	13000922	1
2.2	CLOSING BOLT - BRASS SMAL	13108154	1
2.3	CLOSING PROFILE	13107768	1
2.4	NUT M10-DIN 934	20100277	1
2.5	FIBER RING	20104287	1
2.6	E-RING DIA.5-DIN 6799-S.S	20102018	1
2.7	CLOSING PLATE	13107776	1
2.8	GASKET 15 x 2	30800874	1
2.9	DECAL - ROXELL 73x18	10102697	1
2.10	DECAL - HANDS WARNING	13106596	1
2.11	HARDWARE KIT	13108055	1
2.11.1	NUT M8 DIN 934 - SP	20200119	4
2.11.2	RUBBER CAP M8	16103699	4
2.11.3	KNURLED KNOB	13107842	1
2.11.4	SOCKET CAP SCREW M8X25 - DIN 912	20101978	4
3	ANCHOR & BEARING ASS'Y FA75	13109681	1
3.1	ANCHOR&BEARING SHAFT FA75-90	13109731	1
3.2	RESTRICTOR DIA.36	13105838	1
3.3	ANCHOR TUBE WELDMENT DIA.36	13105853	2
3.4	BEARING 17 X 35 X 10 - 6003 LLU	13201066	1
3.5	SET SCREW M8 x 10 - DIN 916	20100434	1
3.6	CLAMP PIN	13100482	1
3.7	SET SCREW M8X8-DIN 916	20101697	1
3.8	BEARING HOLDER CAP DOWN-DIA.75	13109632	1
3.9	BEARING HOLDER CAP UP - DIA.75	13109624	1
3.10	SEEGER RING DIA. 17 X 1	20101333	1
3.11	HOSE CLAMP Ø70-90	03100658	1
2.12	BOLT M6X12 - DIN 933-8.8	20100160	2
2.13	LOCKNUT M6 - DIN 985	20100400	2

Double intake boot FA 55 / FA 90 - 03000593

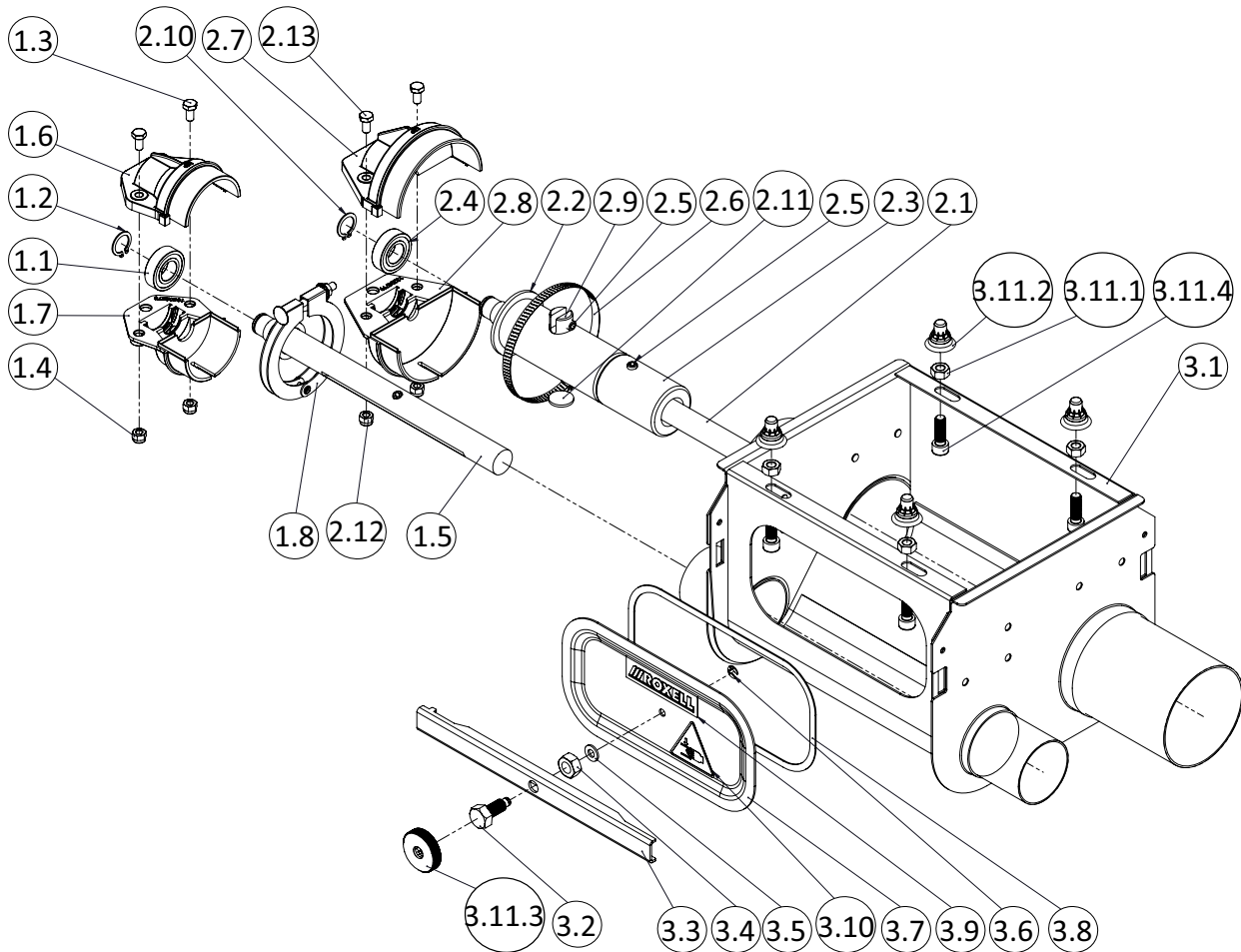

Key	Name	Part Nr.	Qt.
1	ANCHOR & BEARING ASS'Y FA55	13502299	1
1.1	BEARING 17X35X10 - 6003 LLU	13201066	1
1.2	SEEGER RING Ø17X1	20101333	1
1.3	BOLT M6X12 - DIN 933-8.8	20100160	2
1.4	LOCKNUT M6 - DIN 985	20100400	2
1.5	SHAFT FA 55 WELDMENT Ø22 - LG=274MM	13502331	1
1.6	BEARING HOLDER CAP UP - Ø56	13502265	1
1.7	BEARING HOLDER CAP DOWN - Ø56	13502273	1
1.8	TUBE CLAMP ASS'Y Ø63	13601661	1
2	ANCHOR & BEARING ASS'Y FA90	13204011	1
2.1	ANCHOR & BEARING SHAFT FA75-90	13109731	1
2.2	ANCHOR TUBE WELDMENT DIA.44	13201769	1
2.3	RESTRICTOR DIA.44	13201744	1
2.4	BEARING 17 X 35 X 10 - 6003 LLU	13201066	1
2.5	SET SCREW M8 x 10 - DIN 916	20100434	3
2.6	HOSE CLAMP Ø80-100	03200250	1
2.7	BEARING HOLDER CAP UP - DIA.90	13203781	1
2.8	BEARING HOLDER CAP DOWN-DIA.90	13203799	1
2.9	CLAMP PIN	13100482	1
2.10	SEEGER RING DIA. 17 X 1	20101333	1
2.11	SPACER	13200134	2
2.12	LOCKNUT M6 - DIN 985	20100400	2
2.13	BOLT M6X12 - DIN 933-8.8	20100160	2
3	DOUBLE BOOT&CLOS.PL.FA90-FA55	13000963	1
3.1	DOUBLE BOOT WELDMENT FA90-FA55	13000930	1
3.2	CLOSING BOLT - BRASS SMAL	13108154	1

Key	Name	Part Nr.	Qt.
3.3	CLOSING PROFILE	13107768	2
3.4	NUT M10-DIN 934	20100277	1
3.5	FIBER RING	20104287	1
3.6	E-RING DIA.5-DIN 6799-S.S	20102018	1
3.7	CLOSING PLATE	13107776	1
3.8	GASKET 15 x 2	30800874	1
3.9	DECAL - ROXELL 73x18	10102697	1
3.10	DECAL - HANDS WARNING	13106596	1
3.11	HARDWARE KIT	13108055	1
3.11.1	NUT M8 DIN 934 - SP	20200119	4
3.11.2	RUBBER CAP M8	16103699	4
3.11.3	KNURLED KNOB	13107842	1
3.11.4	SOCKET CAP SCREW M8X25 - DIN 912	20101978	4

Double intake boot FA 75 / FA 90 - 03000569

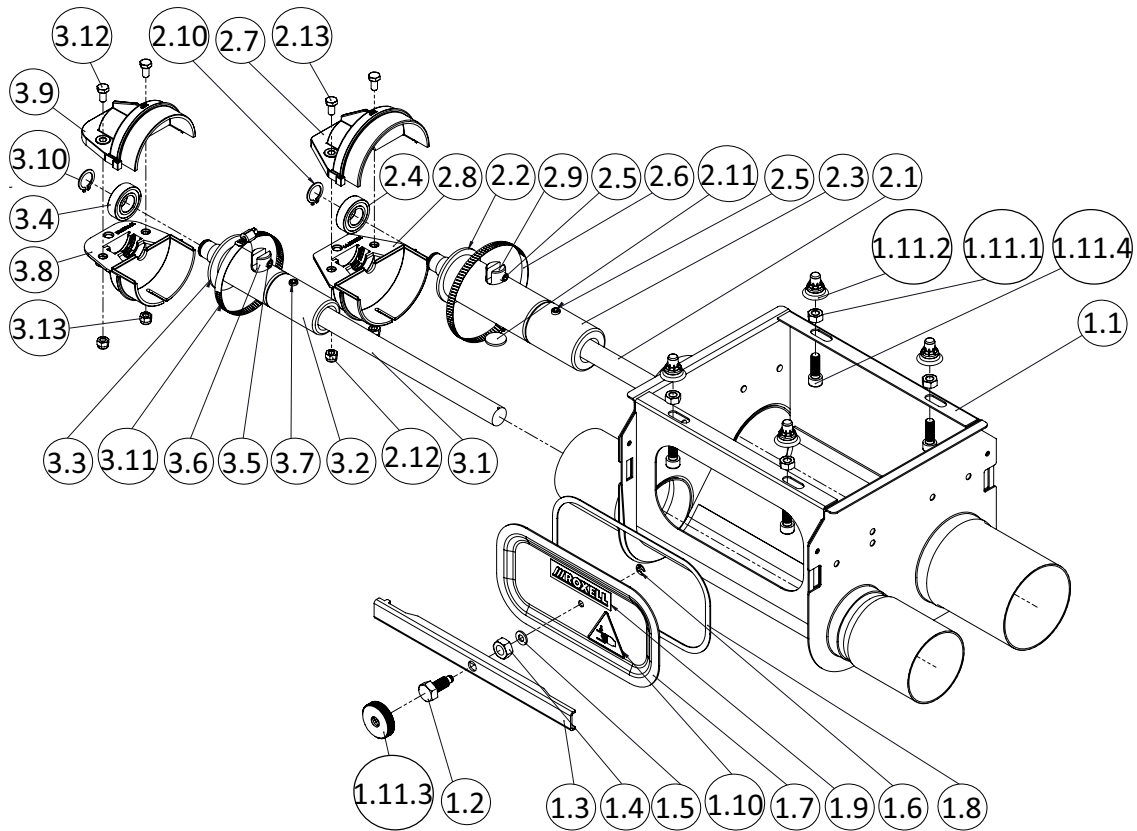

Key	Name	Part Nr.	Qt.
1	DOUBLE BOOT & CLOSING PLATE FA90-FA75	13000948	1
1.1	DOUBLE BOOT WELDMENT FA90-FA75	13000823	1
1.2	CLOSING BOLT - BRASS SMAL	13108154	1
1.3	CLOSING PROFILE	13107768	1
1.4	NUT M10 - DIN 934	20100277	1
1.5	FIBER RING	20104287	1
1.6	E-RING Ø5-DIN 6799-A2 S.S	20102018	1
1.7	CLOSING PLATE	13107776	1
1.8	GASKET 15X2	30800874	1
1.9	DECAL - ROXELL 73x18	10102697	1
1.10	DECAL - HANDS WARNING	13106596	1
1.11	HARDWARE KIT	13108055	1
1.11.1	NUT M8 DIN 934 - SP	20200119	4
1.11.2	RUBBER CAP M8	16103699	4
1.11.3	KNURLED KNOB	13107842	1

Key	Name	Part Nr.	Qt.
1.11.4	SOCKET CAP SCREW M8X25 - DIN 912	20101978	4
2	ANCHOR & BEARING ASS'Y FA90	13204011	1
2.1	ANCHOR & BEARING SHAFT FA75-90	13109731	1
2.2	ANCHOR TUBE WELDMENT Ø44	13201769	1
2.3	RESTRICTOR Ø44	13201744	1
2.4	BEARING 17X35X10 - 6003 LLU	13201066	1
2.5	SET SCREW M8X10 - DIN 916	20100434	3
2.6	HOSE CLAMP Ø80 - 100MM	03200250	1
2.7	BEARING HOLDER CAP UP - Ø90	13203781	1
2.8	BEARING HOLDER CAP DOWN - Ø90	13203799	1
2.9	CLAMP PIN	13100482	1
2.10	SEEGER RING Ø17X1	20101333	1
2.11	SPACER	13200134	1
2.12	LOCKNUT M6 - DIN 985	20100400	1
2.13	BOLT M6X12 - DIN 933-8.8	20100160	1
3	ANCHOR & BEARING ASS'Y FA75	13109681	1
3.1	ANCHOR & BEARING SHAFT FA75-90	13109731	1
3.2	RESTRICTOR Ø36	13105838	1
3.3	ANCHOR TUBE WELDMENT Ø36	13105853	1
3.4	BEARING 17X35X10 - 6003 LLU	13201066	1
3.5	SET SCREW M8X10 - DIN 916	20100434	1
3.6	CLAMP PIN	13100482	1
3.7	SET SCREW M8X8-DIN 916	20101697	1
3.8	BEARING HOLDER CAP DOWN - Ø75	13109632	4
3.9	BEARING HOLDER CAP UP - Ø75	13109624	4
3.10	SEEGER RING Ø17X1	20101333	1
3.11	HOSE CLAMP ASSEMBLY Ø70-90	03100658	4
3.12	BOLT M6X12 - DIN 933-8.8	20100160	1
3.13	LOCKNUT M6 - DIN 985	20100400	1

Multiple intake boot 3 FA 125 – 03001293

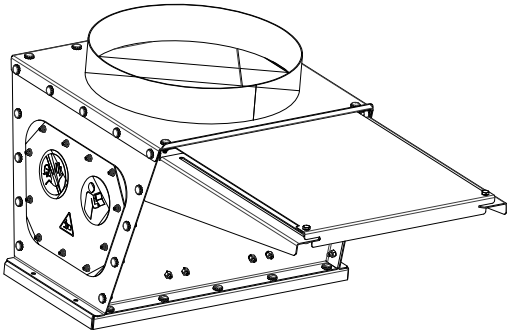

Multiple intake boot 4 FA 125 – 03001277

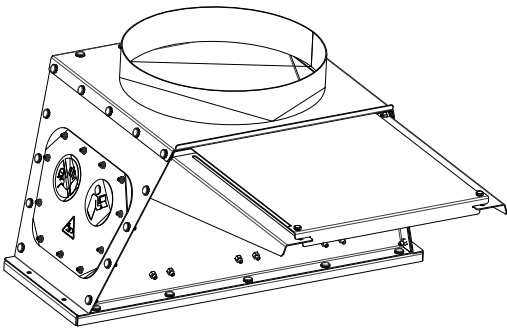

Spares set bearing cap holder

Ø56

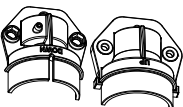
Drawing	Name	Part Nr.	Qt.
	SPARES SET BEAR.CAP HOLD-Ø56	03501368	10
		used in :	
	EXTENSION BOOT FA 55	03501350	
	BOOT ASSEMBLY FA 55	03501335	
	SPARES SET BEAR.CAP HOLD-Ø56	03501368	
	DOUBLE BOOT ASSEMBLY FA90-FA55	03000593	
	DOUBLE BOOT ASSEMBLY FA75-FA55	03000882	

Ø75

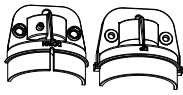
Drawing	Name	Part Nr.	Qt.
	SPARES SET BEAR.CAP HOLD-Ø75	03104254	10
		used in :	
	EXTENSION BOOT - FA 75	03103884	
	BOOT ASSEMBLY FA 75	03103850	
	DOUBLE BOOT ASSEMBLY FA75	03103868	
	DOUBLE BOOT ASSEMBLY FA75-FA55	03000882	
	TANDEM IN LINE FA 75	03103876	
DOUBLE BOOT ASSEMBLY FA90-FA75	03000569		

Ø90

Drawing	Name	Part Nr.	Qt.
	SPARES SET BEAR.CAP HOLD-Ø90	03202726	10
		used in :	
	EXTENSION BOOT FA 90	03202652	
	BOOT ASSEMBLY FA 90	03202629	
	BOOT ASSEMBLY Ø90 FOR AUGER Ø75	03202694	
	DOUBLE BOOT ASSEMBLY FA 90	03202637	
	DOUBLE BOOT ASSEMBLY FA90-FA75	03000569	
	DOUBLE BOOT ASSEMBLY FA90-FA55	03000593	
	TANDEM IN LINE FA 90	03202645	
EXTENSION BOOT FOR OVERHEAD FA90	03202678		

Pellet guides

Pellet guides FA 55 / FA 75 - 03101425

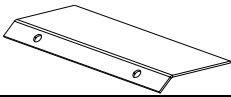
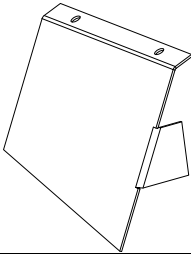
Key	Name	Part Nr.	Qt.
1 	PELLET GUIDE FA 75 - RIGHT HAND	13102470	1
2 	PELLET GUIDE - LEFT HAND	13104716	1

Pellet guides FA 90 - 03200854

Key	Name	Part Nr.	Qt.
1	PELLET GUIDE FA 90 - RIGHT HAND	13200670	1
2	PELLET GUIDE FA 90 - LEFT HAND	13200688	1

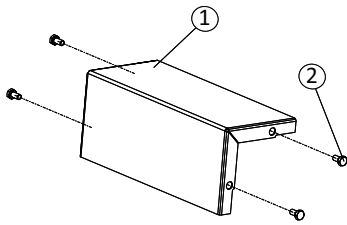
Pellet guides double - 03102910

Key	Name	Part Nr.	Qt.
1	PELLET GUIDE DOUBLE	03102910	1
*2	BOLT M6X12 - DIN 933-8.8	20100160	4
*	INCLUDED IN NR. 1		

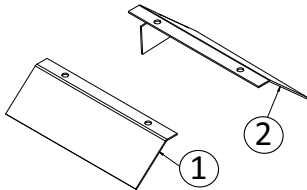
Pellet guides FA 125 - 03700564

Key	Name	Part Nr.	Qt.
1	PELLET GUIDE FA 75 - RIGHT HAND	13102470	1
2	PELLET GUIDE - LEFT HAND	13700083	1

Option: Thumper assemblies

Option: Thumper assembly – 03000007

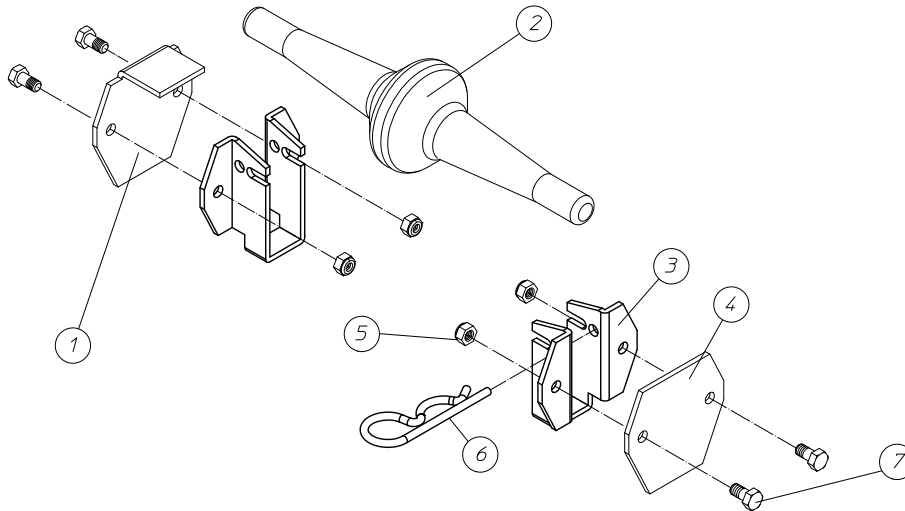

Key	Name	Part Nr.	Qt.
1	THUMPER HOLDER LOCKED	13107990	1
2	THUMPER	13107966	1
3	THUMPER HOLDER	13107974	2
4	THUMPER STOP	13107982	1
5	LOCKNUT M6 - DIN 985	20100400	4
6	SPRING COTTER ø4	20103933	1
7	BOLT M6 X 16 - DIN 933 - 8.8	20100178	4

Option: Thumper assembly FA 125 – 03700556

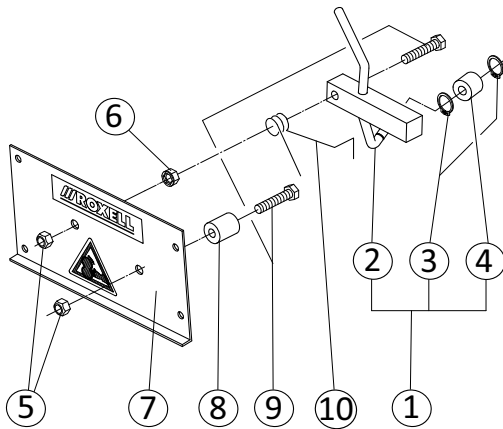

Key	Name	Part Nr.	Qt.
1	THUMPER ASS'Y - FA 125	13701214	1
2	THUMPER WELDMENT FA 125	13701180	1
3	SEEGER RING ø8X0.8 - DIN 471	20101507	2
4	AUGER STUD	13100375	1
5	LOCKNUT M8 - DIN 985	20100418	2
6	NUT WITH SEPARATED FLANGE - M8	20101044	1
7	THUMPER MOUNTING PLATE ASS'Y	13701230	1
8	THUMPER STUD	13100334	1
9	BOLT M8X40 - DIN 933-8.8	20100251	2
10	COMPRESSING SPRING	13102421	1

Extension boots

Extension boot FA 55 - 03501350

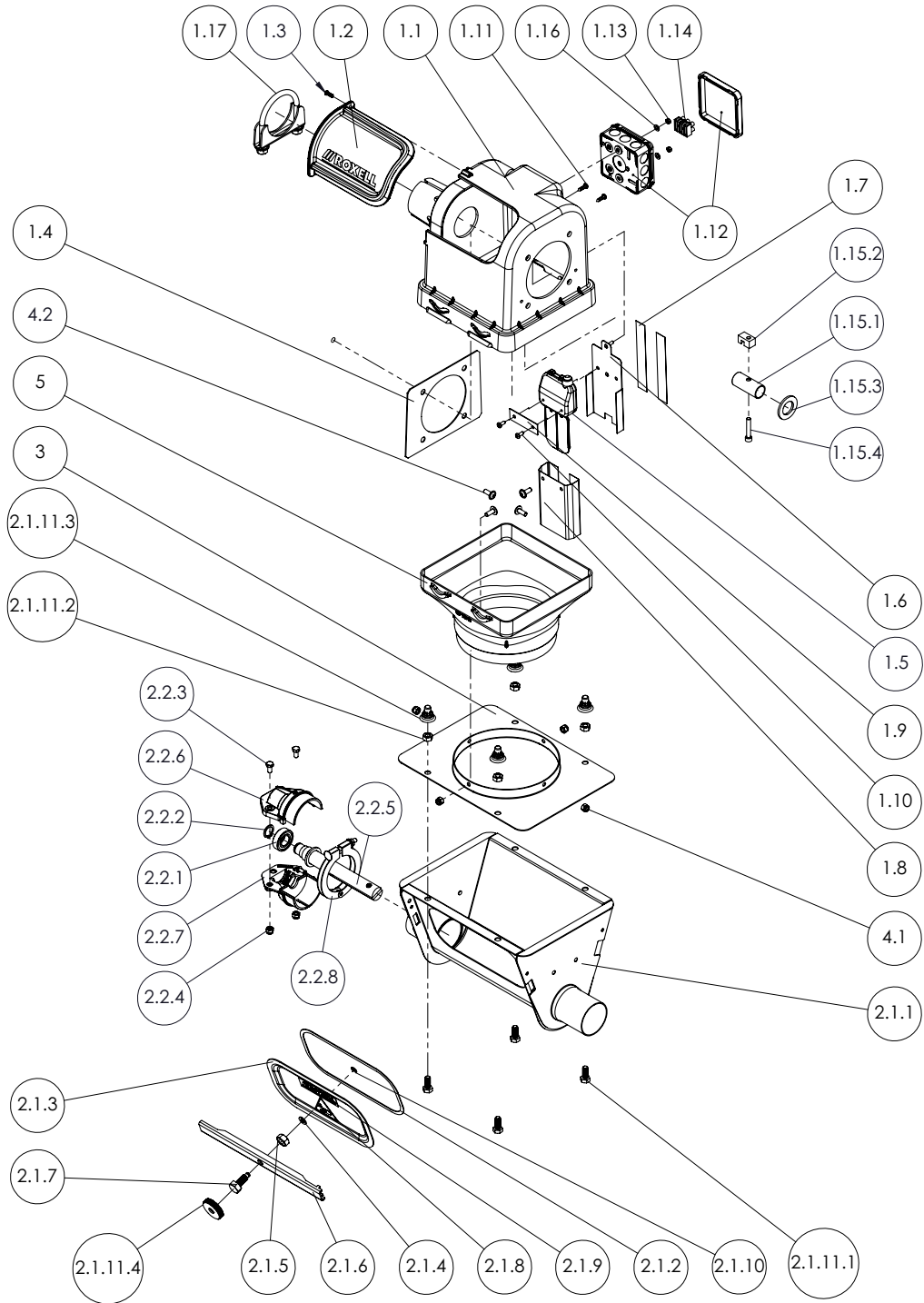

Key	Name	Part Nr.	Qt.
1	CONTROL UNIT FA55 WITHOUT DROP	13502182	1
1.1	HOUSING - CONTROL UNIT Ø56	13502166	1
1.2	WINDOW	13000500	1
1.3	THREAD FORMING SCREW 4X12-A2	12502043	1
1.4	REINFORCEMENT PLATE Ø56-75-90-MOTOR	13109046	1
1.5	SAFETY SWITCH ASS'Y	13104567	1

Key	Name	Part Nr.	Qt.
1.6	SWITCH PLATE W/ PRESS SCREW	13109533	1
1.7	ADHESIVE TAPE 19X0.23-2SIDE	30800726	2
1.8	MINIMUM SWITCH SHIELD	10203115	1
1.9	SWITCH CONNECTION STRIP	13105259	1
1.10	PARCKER SCREW 8 X 1/2"	20100525	2
1.11	PARCKER SCREW 4.2 X 16 - DIN 7981 - A2	20102331	2
1.12	HANDY BOX IPW AX4-IP55	15009814	1
1.13	NUT M4	20100681	2
1.14	CLAMP STROKE 27 20 6E/3	10103109	1
1.15	HARDWARE KIT CU FA 55	13502208	1
1.15.1	DRIVE TUBE	13500434	1
1.15.2	DRIVE BLOCK	10100782	1
1.15.3	GALV.WASHER DIA.39x23x3	20103842	1
1.15.4	SOCKET CAP SCREW M6X35	20102158	1
1.16	WASHER 5.3X10X1 - DIN 125 - A2	20102315	2
1.17	TUBE CLAMP ASSEMBLY Ø67MM	03501293	1
2	BOOT ASS'Y FA55 FOR EXT.BOOT	13502224	1
2.1	INTAKE BOOT & CLOSING PLATE	13502257	1
2.1.1	BOOT BODY WELDMENT FA 55	13501515	1
2.1.2	GASKET 15X2	30800874	1
2.1.3	CLOSING PLATE	13107776	1
2.1.4	FIBER RING	20104287	1
2.1.5	NUT M10 - DIN 934	20100277	1
2.1.6	CLOSING PROFILE	13107768	1
2.1.7	CLOSING BOLT - BRASS SMAL	13108154	1
2.1.8	DECAL - HANDS WARNING	13106596	1
2.1.9	DECAL - ROXELL 73x18	10102697	1
2.1.10	E-RING Ø5-DIN 6799-A2 S.S	20102018	1
2.1.11	HARDWARE KIT EXTENSION BOOT	13000526	1
2.1.11.1	BOLT M8X20 - DIN 933-8.8	20200150	4
2.1.11.2	NUT M8 DIN 934 - SP	20200119	4
2.1.11.3	SEAL CAP M8	16103699	4
2.1.11.4	KNURLED KNOB	13107842	1
2.2	ANCHOR & BEARING ASS'Y FA55	13502307	1
2.2.1	BEARING 17X35X10 - 6003 LLU	13201066	1
2.2.2.	SEEGER RING Ø17X1	20101333	1
2.2.3	BOLT M6X12 - DIN 933-8.8	20100160	2
2.2.4	LOCKNUT M6 - DIN 985	20100400	2
2.2.5	SHAFT WELDMENT	13502281	1
2.2.6	BEARING HOLDER CAP UP - Ø56	13502265	1
2.2.7	BEARING HOLDER CAP DOWN - Ø56	13502273	1
2.2.8	TUBE CLAMP ASS'Y Ø63	13601661	1
3	EXTENSION PLATE Ø160 GALVANISED	13109525	1
4	HW KIT FOR FA EXTENSION 360°	13000518	1
4.1	LOCKNUT M6-DIN 985-A2	20101960	4
4.2	BUT.HEAD CAP SCREW WITH FLANGE M6X16	20109146	4
5	DROP Ø160 FOR EXTENSION BOOT	13000492	1

Key	Name	Part Nr.	Qt.
1.8	MINIMUM SWITCH SHIELD	10203115	1
1.9	SWITCH CONNECTION STRIP	13105259	1
1.10	PARCKER SCREW 8 X 1/2"	20100525	2
1.11	PARCKER SCREW 4.2 X 16 - DIN 7981 - A2	20102331	2
1.12	HANDY BOX IPW AX4-IP55	15009814	1
1.13	NUT M4	20100681	2
1.14	CLAMP STROKE 27 20 6E/3	10103109	1
1.15	DRIVER WELDMENT	13105200	1
1.16	HARDWARE KIT CU FA 75	13109558	1
1.16.1	SOCKET CAP SCREW M8x10-DIN 912	20102778	1
1.16.2	ANCHOR CLAMP	13104575	1
1.16.3	SOCKET CAP SCREW M8X50-DIN 912	20102786	1
1.16.4	LOCKNUT M8 - DIN 985	20100418	2
1.16.5	BOLT M8X20-DIN 933-8.8	20200150	4
1.17	WASHER 5.3X10X1 - DIN 125 - A2	20102315	2
1.18	TUBE CLAMP ASSEMBLY Ø86MM	03103306	1
2	DROP Ø160 FOR EXTENSION BOOT	13000492	1
3	BOOT ASS'Y FA75 FOR EXT.BOOT	13109079	1
3.1	INTAKE BOOT & CLOSING PLATE	13109590	1
3.1.1	BOOT BODY WELDMENT FA 75	13108030	1
3.1.2	GASKET 15 x 2	30800874	1
3.1.3	CLOSING PLATE	13107776	1
3.1.4	FIBER RING	20104287	1
3.1.5	NUT M10-DIN 934	13107768	1
3.1.6	CLOSING PROFILE	13107768	1
3.1.7	CLOSING BOLT - BRASS SMAL	13108154	1
3.1.8	DECAL - HANDS WARNING	13106596	1
3.1.9	DECAL - ROXELL 73x18	10102697	1
3.1.10	E-RING DIA.5-DIN 6799-S.S	20102018	1
3.1.11	HARDWARE KIT EXTENSION BOOT	13000526	1
3.1.11.1	BOLT M8X20-DIN 933-8.8	20200150	4
3.1.11.2	NUT M8 DIN 934 - SP	20200119	4
3.1.11.3	RUBBER CAP M 8	16103699	4
3.1.11.4	KNURLED KNOB	13107842	1
3.2	ANCHOR & BEARING ASS'Y FA75	13109699	1
3.2.1	BEARING HOLDER CAP DOWN - Ø75	13109632	1
3.2.2	BEARING 17X35X10 - 6003 LLU	13201066	1
3.2.3	ANCHOR TUBE WELDMENT Ø36	13109749	1
3.2.4	SEEGER RING Ø17X1	20101333	1
3.2.5	HOSE CLAMP ASSEMBLY Ø70-90	03100658	1
3.2.6	BEARING HOLDER CAP UP - Ø75	13109624	1
3.2.7	BOLT M6X12 - DIN 933-8.8	20100160	2
3.2.8	LOCKNUT M6 - DIN 985	20100400	2
4	EXTENSION PLATE Ø160 GALVANISED	13109525	1
5	HW KIT FOR FA EXTENSION 360°	13000518	1
5.1	LOCKNUT M6-DIN 985-A2	20101960	4
5.2	BUT.HEAD CAP SCREW WITH FLANGE M6X16-A2	20109146	4

Extension boot FA 90 - 03202652

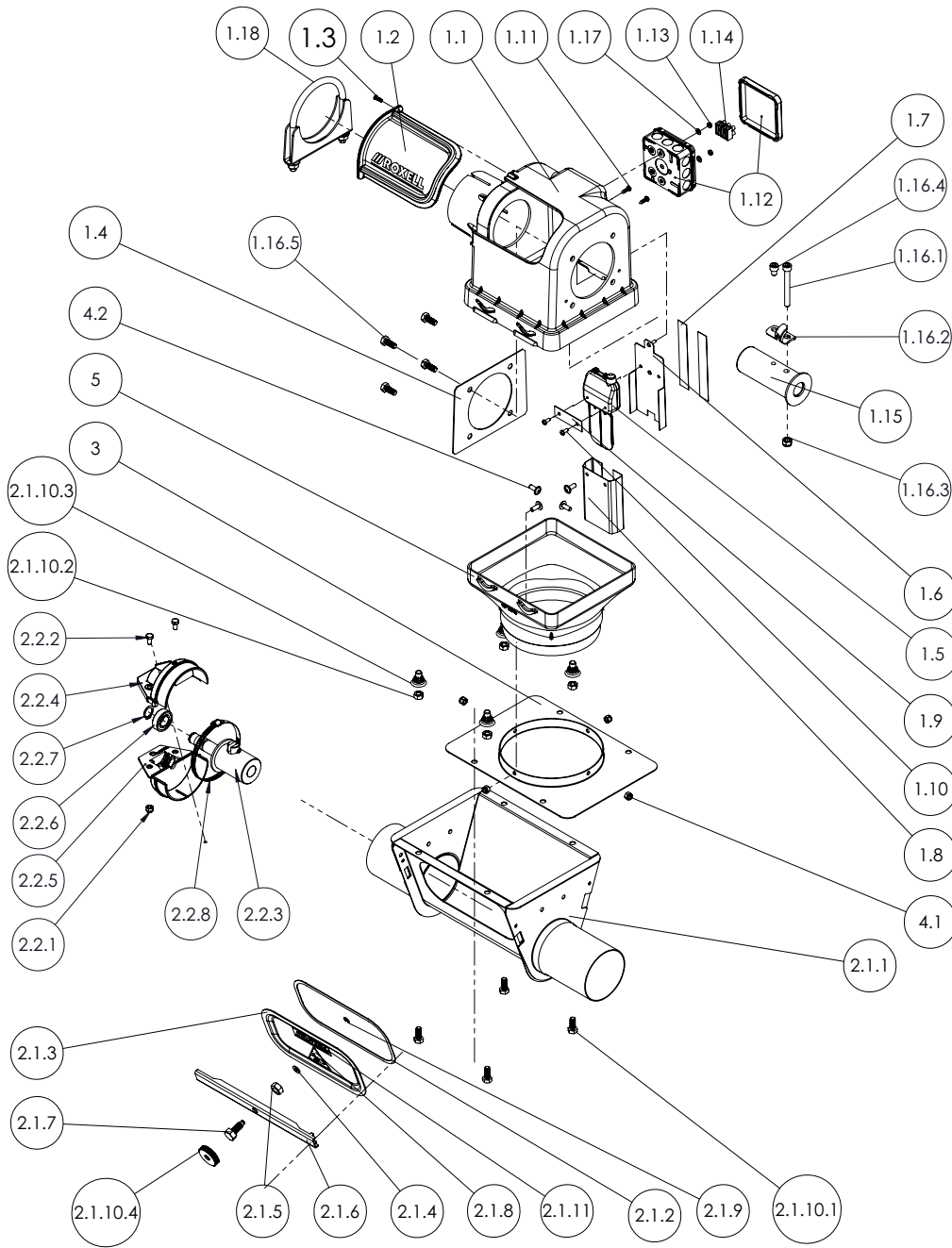

Key	Name	Part Nr.	Qt.
1	CONTROL UNIT FA90 W/O DROP	13203823	1
1.1	HOUSING - CONTROL UNIT Ø89	13203807	1
1.2	WINDOW	13000500	1
1.3	THREAD FORMING SCREW 4X12-A2	12502043	1
1.4	REINFORCEMENT PLATE Ø56-75-90-MOTOR	13109046	1
1.5	SAFETY SWITCH ASS'Y	13104567	1
1.6	SWITCH PLATE W/ PRESS SCREW	13109533	1
1.7	ADHESIVE TAPE 19X0.23-2SIDE	30800726	2
1.8	MINIMUM SWITCH SHIELD	10203115	1
1.9	SWITCH CONNECTION STRIP	13105259	1
1.10	PARCKER SCREW 8X1/2"	20100525	2
1.11	PARCKER SCREW 4.2X16 - DIN 7981	20102331	2

Key	Name	Part Nr.	Qt.
1.12	HANDY BOX IPW AX4-IP55	15009814	1
1.13	NUT M4	20100681	2
1.14	CLAMP STROKE 27 20 6E/3	10103109	1
1.15	DRIVER WELDMENT	13201561	1
1.16	HARDWARE KIT CU FA 90	13203849	1
1.16.1	SOCKET CAP SCREW M8X70 - DIN 912	20101986	1
1.16.2	ANCHOR CLAMP	13104575	1
1.16.3	LOCKNUT M8 - DIN 985	20100418	1
1.16.4	SOCKET CAP SCREW M8X10 - DIN 912	20102778	1
1.16.5	BOLT M8X20 - DIN 933-8.8	20200150	4
1.17	WASHER 5.3X10X1 - DIN 125 - A2	20102315	2
1.18	TUBE CLAMP ASSEMBLY Ø100MM	03202561	1
2	BOOT ASS'Y FA90 FOR EXT.BOOT	13203963	1
2.1	INTAKE BOOT & CLOSING PLATE FA90	13204003	1
2.1.1	BOOT BODY WELDMENT FA 90	13202965	1
2.1.2	GASKET 15X2	30800874	1
2.1.3	CLOSING PLATE	13107776	1
2.1.4	FIBER RING	20104287	1
2.1.5	NUT M10 - DIN 934	20100277	1
2.1.6	CLOSING PROFILE	13107768	1
2.1.7	CLOSING BOLT - BRASS SMAL	13108154	1
2.1.8	DECAL - HANDS WARNING	13106596	1
2.1.9	E-RING Ø5-DIN 6799-A2 S.S	20102018	1
2.1.10	HARDWARE KIT EXTENSION BOOT	13000526	1
2.1.10.1	BOLT M8X20 - DIN 933-8.8	20200150	4
2.1.10.2	NUT M8 DIN 934 - SP	20200119	4
2.1.10.3	SEAL CAP M8	16103699	4
2.1.10.4	KNURLED KNOB	13107842	1
2.1.11	DECAL - ROXELL 73x18	10102697	1
2.2	ANCHOR & BEARING ASS'Y FA90	13204037	1
2.2.1	LOCKNUT M6 - DIN 985	20100400	2
2.2.2	BOLT M6X12 - DIN 933-8.8	20100160	2
2.2.3	ANCHOR TUBE WELDMENT DIA.44	13204045	1
2.2.4	BEARING HOLDER CAP UP - Ø90	13203781	1
2.2.5	BEARING HOLDER CAP DOWN - Ø90	13203799	1
2.2.6	BEARING 17X35X10 - 6003 LLU	13201066	1
2.2.7	SEEGER RING Ø17X1	20101333	1
2.2.8	HOSE CLAMP Ø80 - 100MM	03200250	1
3	EXTENSION PLATE Ø160 GALVANISED	13109525	1
4	HW KIT FOR FA EXTENSION 360°	13000518	1
4.1	LOCKNUT M6-DIN 985-A2	20101960	4
4.2	BUT.HEAD CAP SCREW WITH FLANGE M6X16-A2	20109146	4
5	DROP Ø160 FOR EXTENSION BOOT	13000492	1

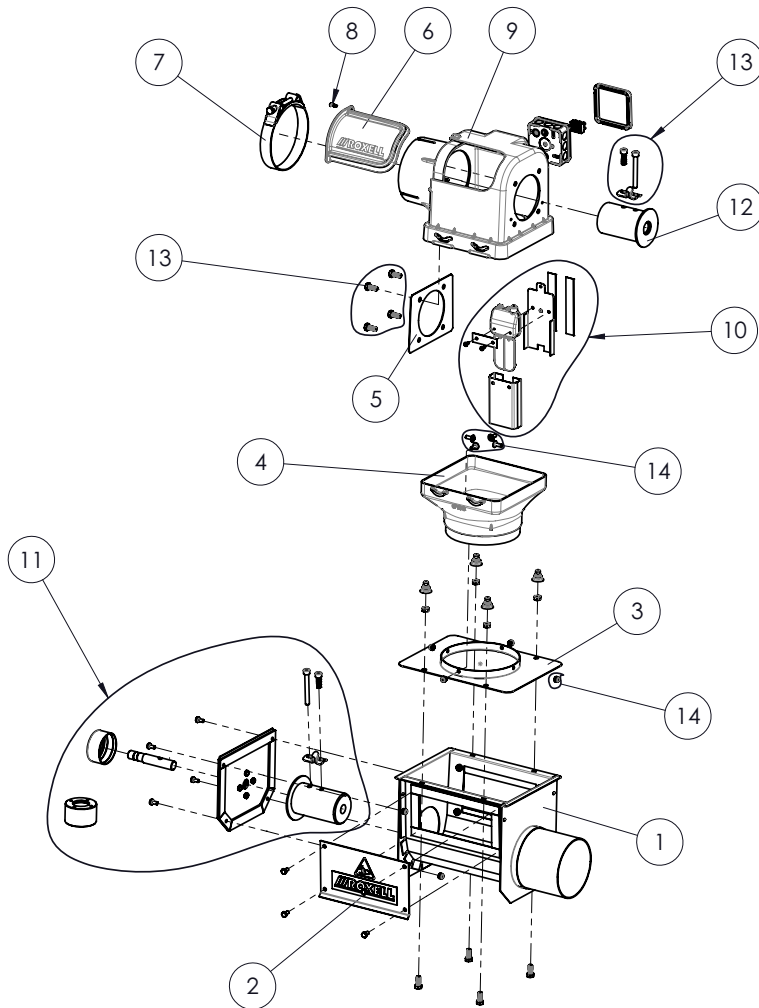
Extension boot FA 125 - 03701092

Key	Name	Part Nr.
1	BOOT BODY WELDMENT	13701081
2	CLOSING PLATE ASS'Y	13102629
3	ANCHOR + BEARING ASS'Y FA125	13701016
4	BOLT M6X12 - DIN 933-8.8	20100160
5	EXTENSION PLATE Ø160 GALVA	13109525
6	BOLT M8X20-DIN 933-8.8	20200150
7	NUT M8 - DIN 934	20200028
8	RUBBER CAP M 8	16103699
9	DROP Ø160 FOR EXTENSION BOOT	13000492
10	BUT.HEAD CAP SCREW W/FLANGE M6x16-A2	20109146
11	LOCKNUT M6 - DIN 985 -A2	20101960
12	CONTROL UNIT FA125 W/O DROP	13703212
13	LOCKNUT M6 - DIN 985	20100400

Outlet drop assemblies with shut-off

Model FA 55

Drawing	Key	Name	Part Nr.	Qt.	
	1	BOTTOM PIECE - OUTLET DIA56	03501319	1	
	2	TOP PIECE - OUTLET DIA56	03501301	1	
	3	CLOSING SLIDE - OUTLET DIA56	03501327	1	
	*4	INDICATOR BEAD RED	13201355	1	
	*5	INDICATOR BEAD GREEN	13201363	1	
	*6	SLIDE ROPE	13103916	1	
	*7	PARCKER SCREW 4.2 X 16 - DIN 7981 - A2	20102331	6	
	*	SLIDE ROPE + HARDWARE KIT	03000395	1	

Model FA 75

Drawing	Key	Name	Part Nr.	Qt.	
	1	BOTTOM PIECE - OUTLET DIA75	03103363	1	
	2	TOP PIECE - OUTLET DIA75	03103330	1	
	3	CLOSING SLIDE - OUTLET DIA75	03103371	1	
	*4	INDICATOR BEAD RED	13201355	1	
	*5	INDICATOR BEAD GREEN	13201363	1	
	*6	SLIDE ROPE	13103916	1	
	*7	PARCKER SCREW 4.2 X 16 - DIN 7981 - A2	20102331	6	
	*	SLIDE ROPE + HARDWARE KIT	03000395	1	

Model FA 90

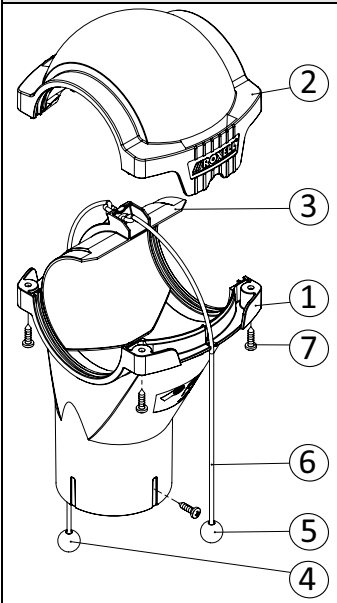
Drawing	Key	Name	Part Nr.	Qt.
	1	BOTTOM PIECE - OUTLET DIA90	03202603	1
	2	TOP PIECE - OUTLET DIA90	03202595	1
	3	CLOSING SLIDE - OUTLET DIA90	03202611	1
	*4	INDICATOR BEAD RED	13201355	1
	*5	INDICATOR BEAD GREEN	13201363	1
	*6	SLIDE ROPE	13103916	1
	*7	PARCKER SCREW 4.2 X 16 - DIN 7981	20102331	6
	*	SLIDE ROPE + HARDWARE KIT	03000395	1

Model FA 125

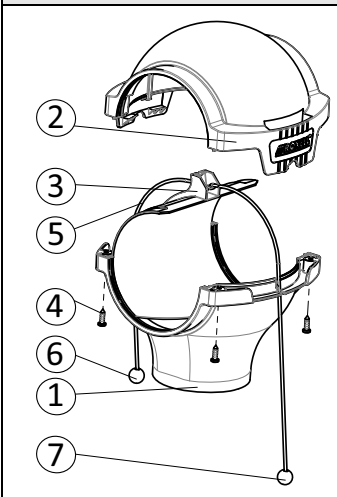
Drawing	Key	Name	Part Nr.	Qt.
	1	BOTTOM PIECE - OUTLET DIA125	03701004	1
	2	TOP PIECE - OUTLET DIA125	03700996	1
	3	CLOSING SLIDE - OUTLET DIA125	03701012	1
	*4	PARCKER SCREW 4.2 X 16 - DIN 7981 - A2	20102331	4
	*5	SLIDE ROPE	13103916	1
	*6	INDICATOR BEAD RED	13201355	1
	*7	INDICATOR BEAD GREEN	13201363	1
	*	SLIDE ROPE + HARDWARE KIT	03000395	1

Automatic outlets

Automatic outlet – Ø56 – 24 V DC(I) – 04906954

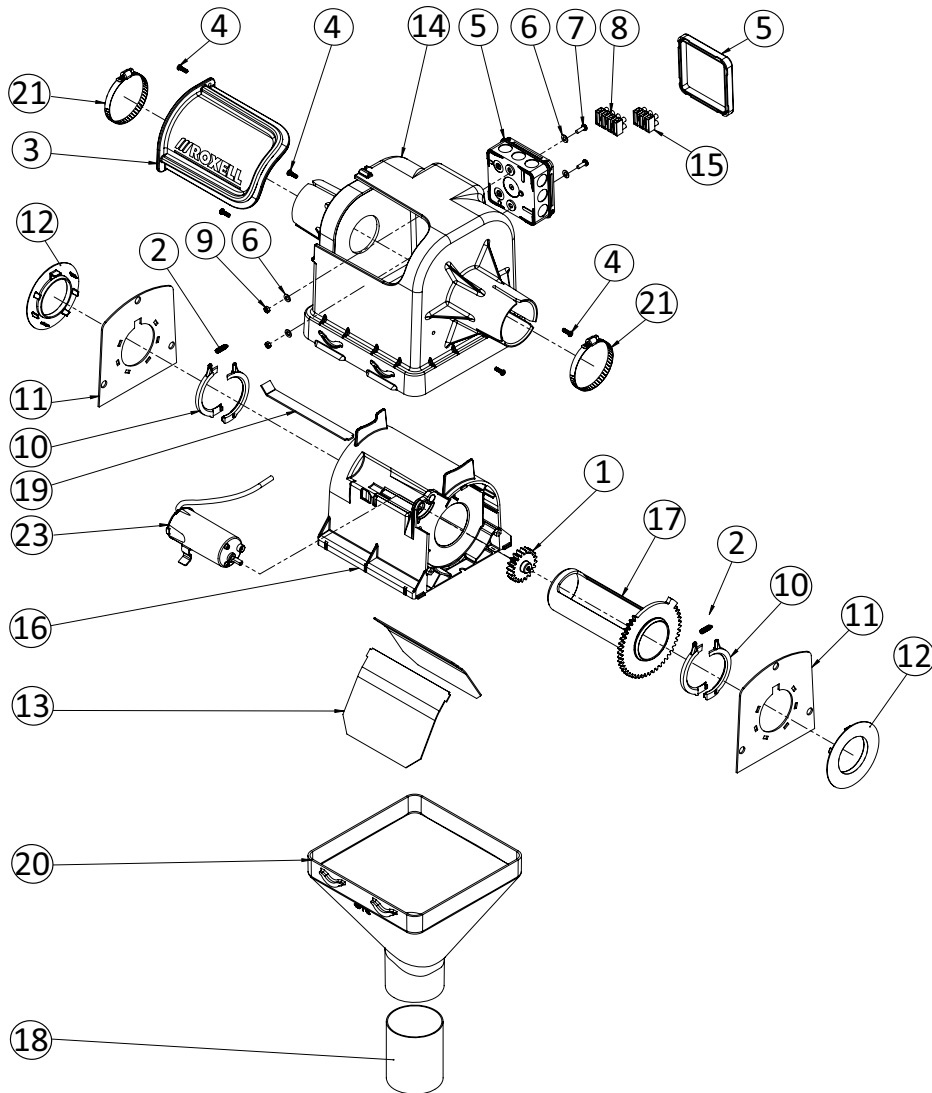

Key	Name	Part Nr.	Qt.	Key	Name	Part Nr.	Qt.
1	GEARWHEEL 2M 20T 20PA	14905459	1	12	BEARING RING DIA 56	14915029	2
2	SPRING DIA 5 x 20.2	14905624	2	13	CLOSING PLATE Ø56 1.5MM	14905673	2
3	WINDOW	13000500	1	14	HOUSING - AUTO OUTLET DIA 56	14905616	1
4	THREAD FORMING SCREW 4X12-A2	12502043	5	15	CLAMP STROKE 27 20 6E/3	10103109	1
5	HANDY BOX IPW AX4-IP55	15009814	1	16	INNER HOUSING DIA 56	14905566	1
6	WASHER 5.3X10X1 - DIN 125 - A2	20102315	4	17	OUTLET TUBE WITH GEAR DIA 56	14905533	1
7	HEAD SCR. M4X12 DIN7985Z-A2	20109567	2	18	INSERT TUBE F/DROP DIA. 70MM	13000534	1
8	CLAMP STROKE 6E/4	10110799	1	19	STAINLESS STEEL STRIP	14905855	1
9	NUT M4 DIN 934 - A2	20102646	2	20	DROP FOR DROP TUBE DIA 70	13502174	1
10	FLEXIBLE CLOSING RING DIA 56	14905509	4	21	TUBE CLAMP DIA. 50/70 MM	13600622	2
11	REINFORCEMENT PLATE Ø56	14915052	2	23	MOTOR SET F/AUTOMATIC OUTLET (I)	04906715	1

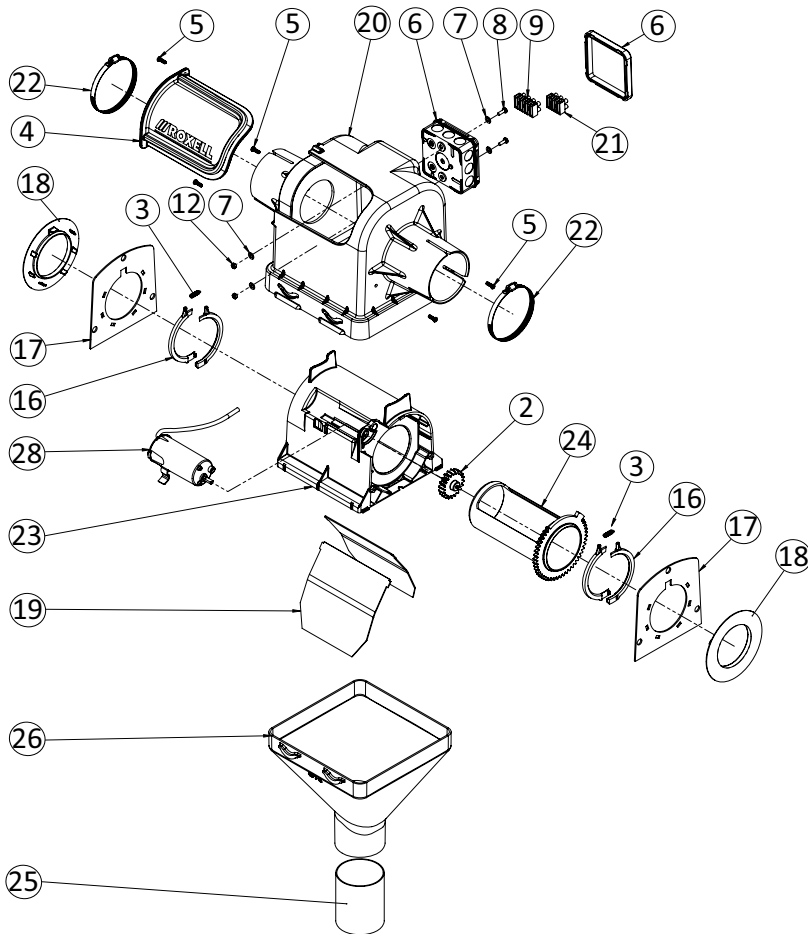
Automatic outlet – Ø75 – 24 V DC(I) – 04906962

Key	Name	Part Nr.	Qt.	Key	Name	Part Nr.	Qt.
2	GEARWHEEL 2M 20T 20PA	14905459	1	18	BEARING RING DIA 75	14915037	2
3	SPRING DIA 5 x 20.2	14905624	2	19	CLOSING PLATE Ø90 1.0MM	14905681	2
4	WINDOW	13000500	1	20	HOUSING - AUTO OUTLET DIA 75	14905608	1
5	THREAD FORMING SCREW 4X12-A2	12502043	5	21	CLAMP STROKE 27 20 6E/3	10103109	1
6	HANDY BOX IPW AX4-IP55	15009814	1	22	HOSE CLAMP ø80-100	03200250	2
7	WASHER 5.3X10X1 - DIN 125 - A2	20102315	4	23	INNER HOUSING DIA 75	14905574	1
8	HEAD SCR. M4X12 DIN7985Z-A2	20109567	2	24	OUTLET TUBE WITH GEAR DIA 75	14905541	1
9	CLAMP STROKE 6E/4	10110799	1	25	INSERT TUBE F/DROP DIA. 70MM	13000534	1
12	NUT M4 DIN 934 - A2	20102646	2	26	DROP FOR DROP TUBE DIA 70	13502174	1
16	FLEXIBLE CLOSING RING DIA 75	14905517	4	27	INSTRUCTION SHEET OUTLET (I)	14905384	1
17	REINFORCEMENT PLATE Ø75	14915060	2	28	MOTOR SET F/AUTOMATIC OUTLET (I)	04906715	1

Automatic outlet – Ø89 – 24 V DC(I) – 04906913

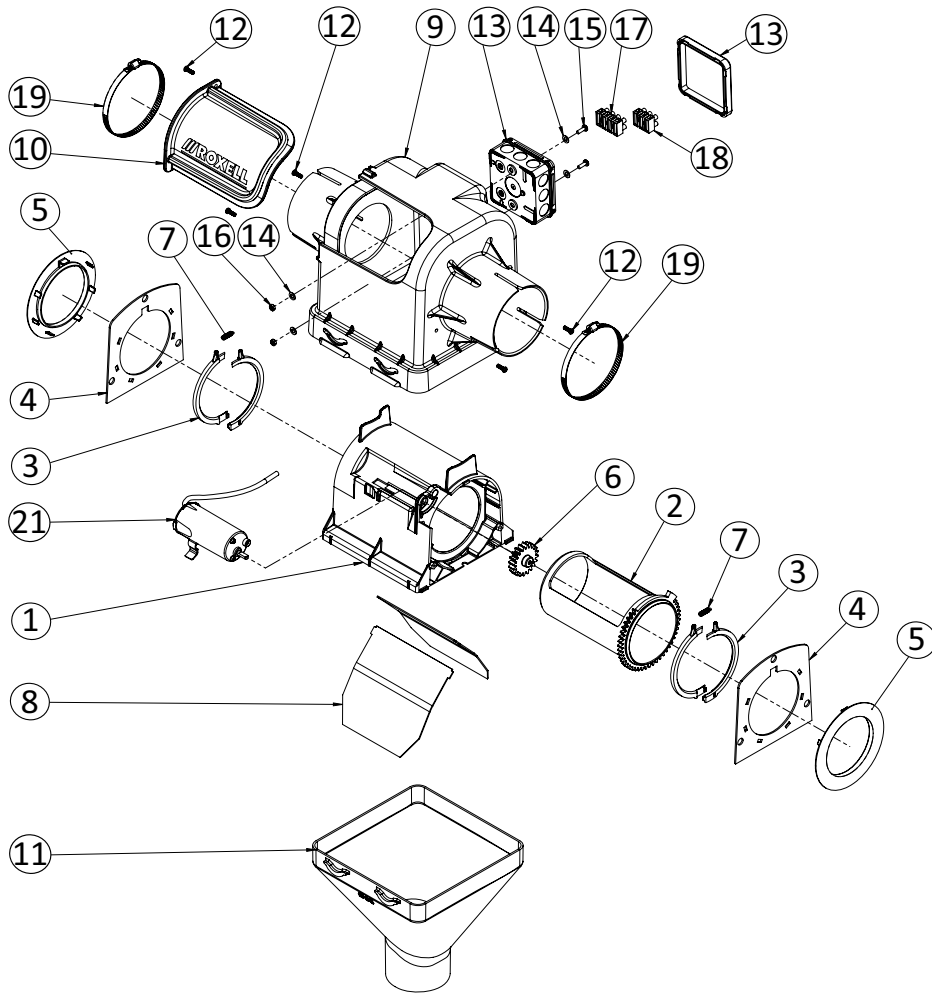

Key	Name	Part Nr.	Qt.	Key	Name	Part Nr.	Qt.
1	INNER HOUSING DIA 89	14905582	1	12	THREAD FORMING SCREW 4X12-A2	12502043	5
2	OUTLET TUBE WITH GEAR DIA 89	14905558	1	13	HANDY BOX IPW AX4-IP55	15009814	1
3	FLEXIBLE CLOSING RING DIA 89	14905525	4	14	WASHER 5.3X10X1 - DIN 125 - A2	20102315	4
4	REINFORCEMENT PLATE DIA.89	14914972	2	15	HEAD SCR. M4X12 DIN7985Z-A2	20109567	2
5	BEARING RING Ø89MM	14914964	2	16	NUT M4 DIN 934 - A2	20102646	2
6	GEARWHEEL 2M 20T 20PA	14905459	1	17	CLAMP STROKE 6E/4	10110799	1
7	SPRING DIA 5 x 20.2	14905624	2	18	CLAMP STROKE 27 20 6E/3	10103109	1
8	CLOSING PLATE Ø90 1.0MM	14905681	2	19	HOSE CLAMP ø80-100	03200250	2
9	HOUSING - AUTO OUTLET DIA 89	14905590	1	20	INSTRUCTION SHEET OUTLET (I)	14905384	1
10	WINDOW	13000500	1	21	MOTOR SET F/AUTOMATIC OUTLET (I)	04906715	1
11	DROP FOR DROP TUBE DIA 85	13203815	1				

Automatic outlet – $\phi 125$ – 24 V DC(I) – 04918896

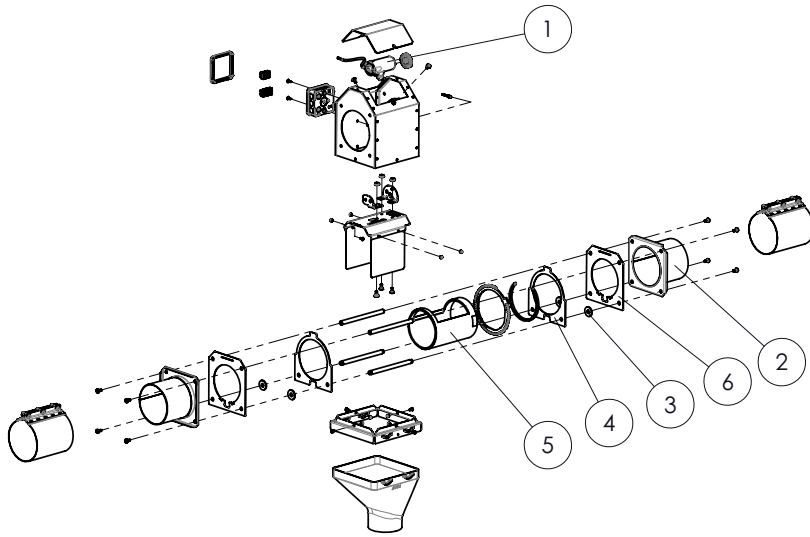

Key	Name	Part Nr.
1	MOTOR SET F/AUTOMATIC OUTLET $\phi 125$	04909372
2	TUBE ANCHOR WELDMENT $\phi 125$	14916527
3	SEAL WASHER	14919156
4	BEARING PLATE $\phi 125$	14919148
5	OUTLET TUBE $\phi 125$	14916495
6	INTERMEDIATE PLATE $\phi 125$	14919140

Telescopical drop tube - 03100435

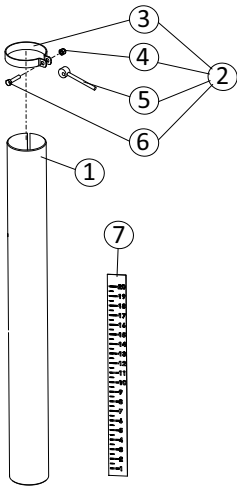

Key	Name	Part Nr.	Qt.
1	TELESCOPICAL TUBE	13100029	1
2	CLAMP ASS'Y	13103650	1
3	CLAMP DIAMETER 75	10107563	1
4	LOCKNUT M6 - DIN 985	20100400	1
5	EXENTRIC ARM	13107933	1
6	BOLT M6 X 30 - DIN 933 - 8.8	20100194	1
7	FEED LEVEL DECAL	13104179	1

Level switches

Hopper level switch - 03100864

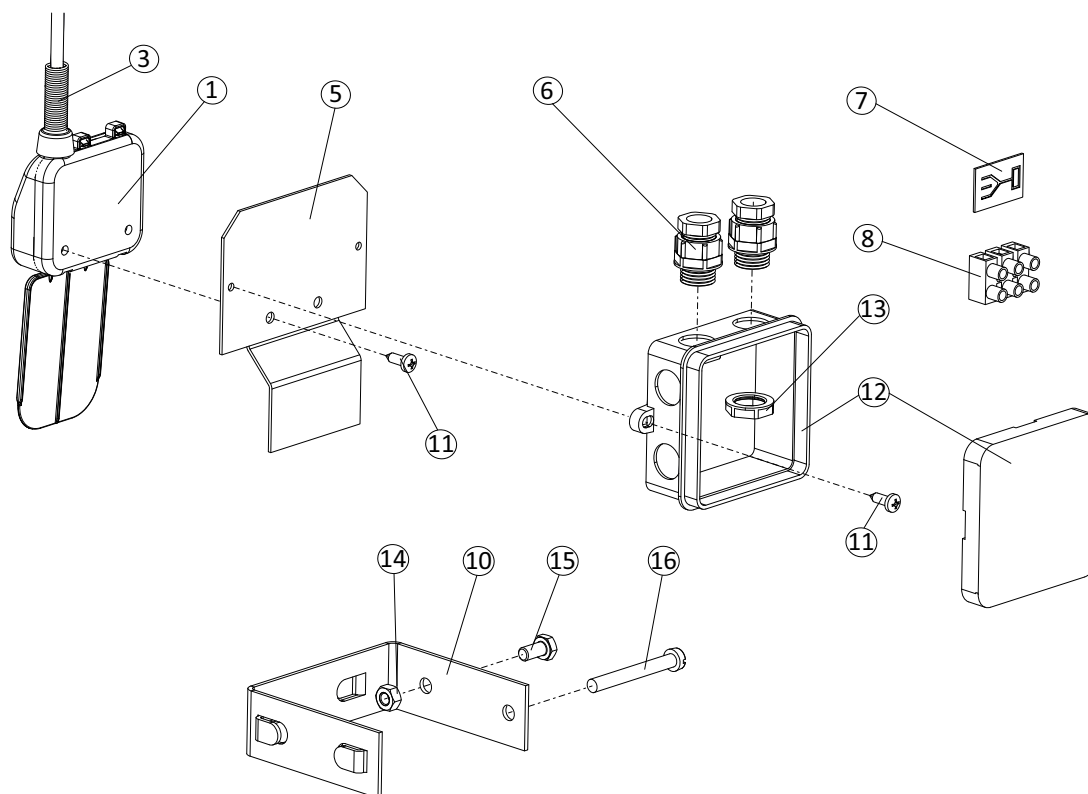

Key	Name	Part Nr.	Qt.
1	LEVEL SWITCH ASS'Y	13104500	1
3	SWITCH CORD GUARD	13104369	1
5	CONNECTION PLATE	13104401	1
6	CABLE RING PG 9	15001472	2
7	ELECTRICAL CONNECTION DECAL	13104534	1
8	CLAMP STROKE 27 20 6E/3	10103109	1
10	INSTALLATION BRACKET	13104419	1
11	PARCKER SCREW 8 X 1/2"	20100525	4
12	HANDY BOX OBO A8	15000037	1
13	CABLE RING NUT PG 9 poly. G.V.	10102978	2
14	NUT M6 - DIN 934	20100210	2
15	BOLT M6 X 12 - DIN 933-8.8	20100160	2
16	SCREW CHEESE HEAD M6X25 DIN84 - A2	20200283	2

Level switch for tube - 03000551

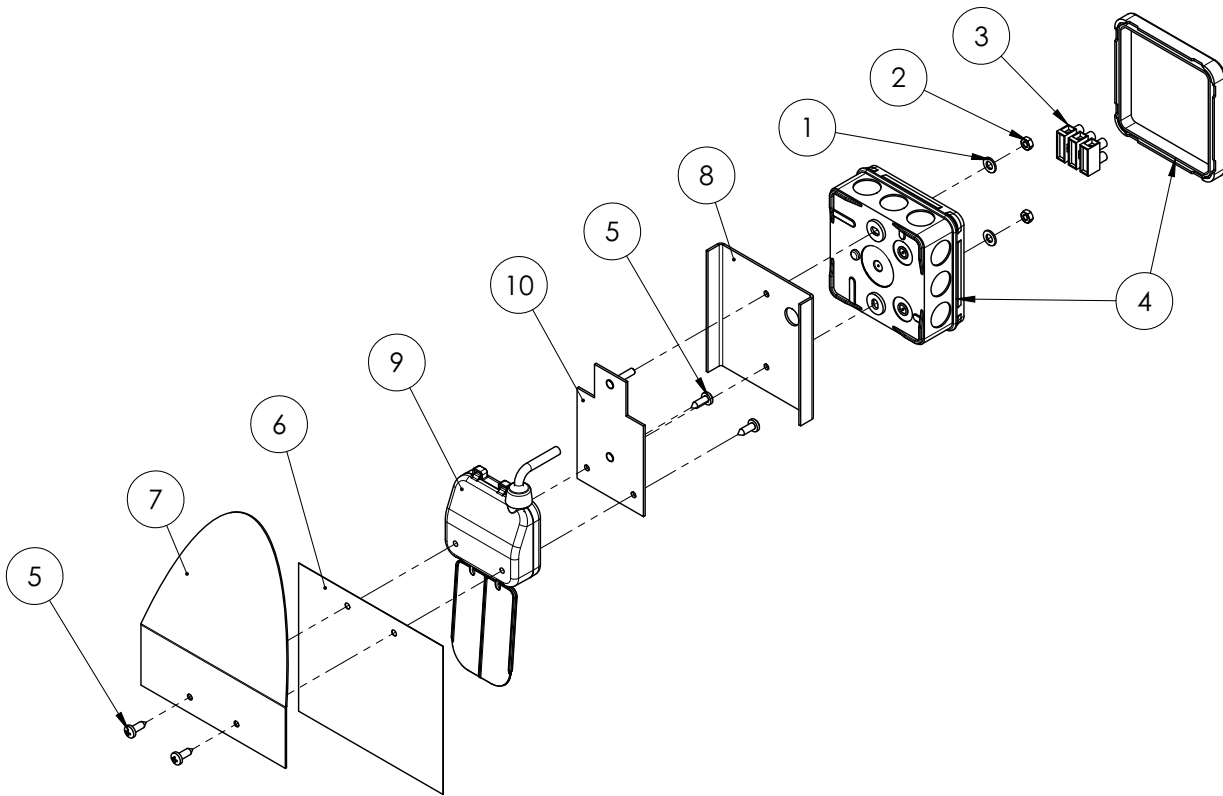

Key	Name	Part Nr.	Qt.
1	WASHER 5.3X10X1 - DIN 125 - A2	20102315	2
2	NUT M4	20100681	2
3	CLAMP STROKE 27 20 6E/3	10103109	1
4	HANDY BOX IPW AX4-IP55	15009814	1
5	PARCKER SCREW 8 X 1/2"	20100525	4
6	SWITCH SHIELD	14905863	1
7	PROTECTION PLATE - LEVEL SWITCH	14915177	1
8	CONN. BOX MOUNTING PLATE	14905897	1
9	LEVEL SWITCH ASS'Y	13104500	1
10	SWITCH MOUNTING PLATE	14905889	1

Drop tube level switch w/delay - 03100872

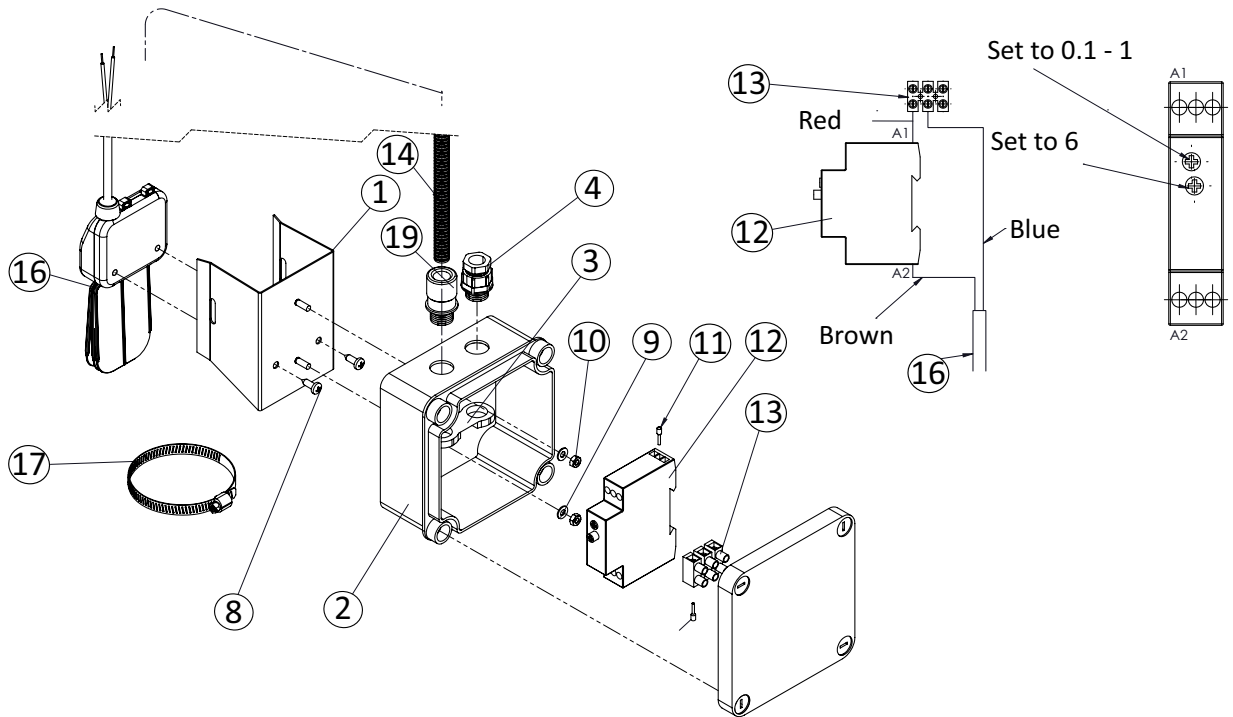

Key	Name	Part Nr.	Qt.
1	DROP TUBE BRACKET	13109764	1
2	JUNCTION BOX DROP TUBE LEVEL SWITCH	14915839	1
3	CABLE RING HOLDER (2xPG9)	15010119	1
4	CABLE RING PG 9	15001472	1
8	PARCKER SCREW 8 X 1/2"	20100525	2
9	WASHER 4.3x9x0.8	20100566	2
10	NUT M4	20100681	2
11	END SLEEVE 0.75MM ² BU	15011942	2
12	ADJUSTABLE TIME DELAY (0.1s-100h)	13109756	1
13	CLAMP STROKE 27 20 6E/3	10103109	1
14	FLEXTUBE KIXoo/VIToo CTRL PAN	15010556	1
19	FLEXTUBE CONNECTOR	15009319	1
16	LEVEL SWITCH ASS'Y	13104500	1
17	HOSE CLAMP Ø70-90	03100658	1

Drop tube level switch - 03101102

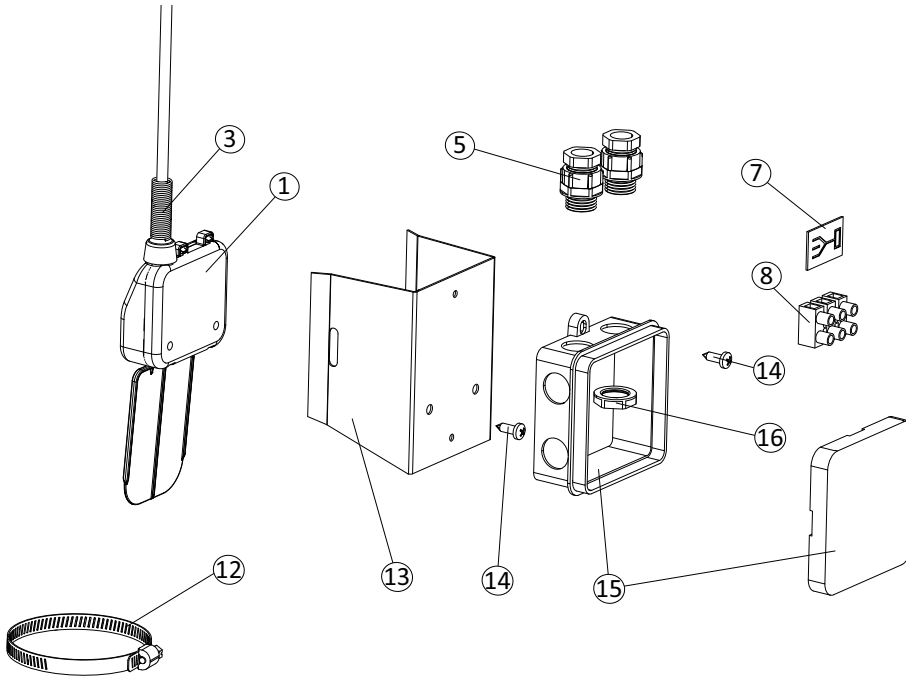

Key	Name	Part Nr.	Qt.
1	LEVEL SWITCH ASS'Y	13104500	1
3	SWITCH CORD GUARD	13104369	1
5	CABLE RING PG 9	15001472	2
7	ELECTRICAL CONNECTION DECAL	13104534	1
8	CLAMP STROKE 27 20 6E/3	10103109	1
12	HOSE CLAMP Ø70-90	03100658	1
13	DROP TUBE BRACKET	13104377	1
14	PARCKER SCREW 8 X 1/2"	20100525	4
15	HANDY BOX OBO A8	15000037	1
16	CABLE RING NUT PG 9 poly. G.V.	10102978	2

Safety switch - 13000757

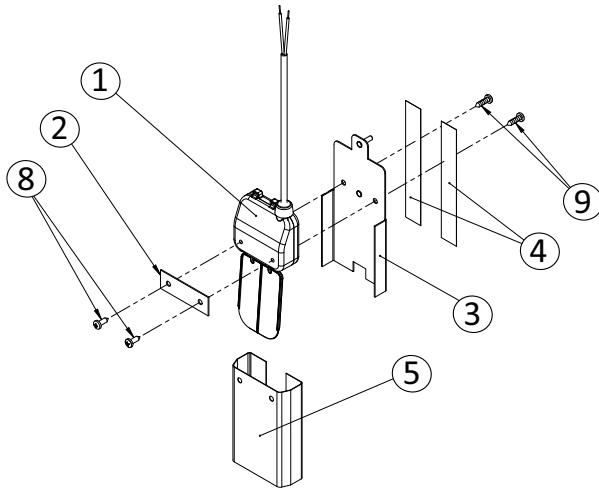

Key	Name	Part Nr.	Qt.
1	SAFETY SWITCH ASS'Y	13104567	1
2	SWITCH CONNECTION STRIP	13105259	1
3	SWITCH PLATE W/ PRESS SCREW	13109533	1
4	ADHESIVE TAPE 19X0.23-2SIDE	30800726	2
5	MINIMUM SWITCH SHIELD	10203115	1
8	PARCKER SCREW 8 X 1/2"	20100525	2
9	PARCKER SCREW 4.2 X 16 - DIN 7981 - A2	20102331	2

Sensor holder + connection kit - 03103074

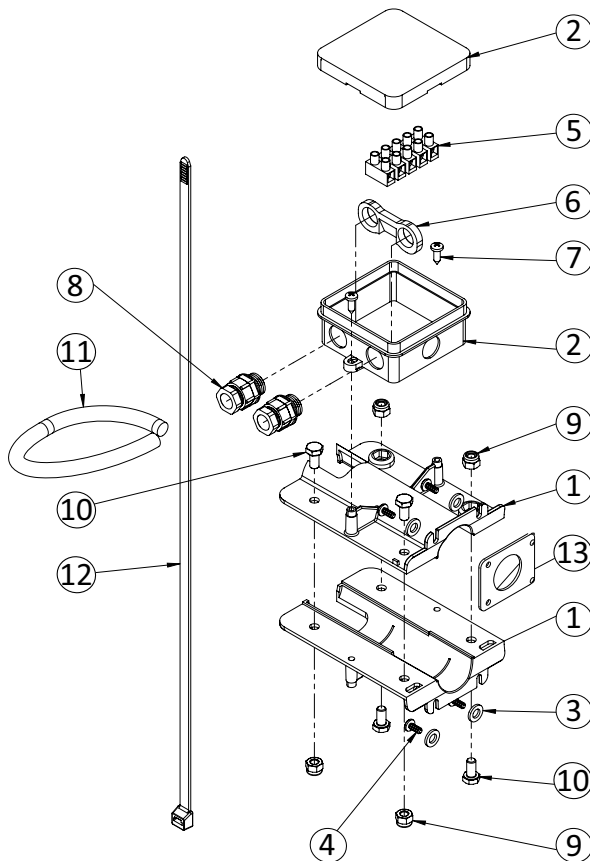

Key	Name	Part Nr.	Qt.
1	SENSOR HOLDER	13000443	2
2	HANDY BOX OBO A8	15000037	1
3	WASHER D.6.6x12x1.6-DIN 126	20100459	4
4	PARCKER SCREW 4.2x9.5 DIN 7981FH	20103859	4
5	CLAMP STROKE 47 40 6E/5	13303086	1
6	CABLE RING HOLDER (2xPG9)	15010119	1
7	PARCKER SCREW 8 X 1/2"	20100525	2
8	CABLE RING PG 9	15001472	2
9	LOCKNUT M6 - DIN 985 -A2	20101960	4
10	BOLT M6X12-DIN 933-A2	20103883	4
11	CABLE GUARD LG=220MM	13109145	1
12	WRAP-IT-TIE	13105309	2
13	SEALING RUBBER FOR SENSOR	13018174	1

Sensors

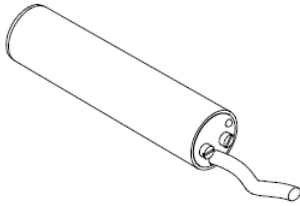

24 V DC sensors		
Key	Name	Specifications
03104538	SENSOR VC12 RTM24106821-1 24-230 V AC/DC	D = 6 mm, T = 5 s
03104586	SENSOR VC12 RTM24106821-2 24-230 V AC/DC	D = 3 mm, T = 1 s
03104578	SENSOR VC12 RTM24106821-3 24-230 V AC/DC	D = 3 mm, T = 30 s
230 V AC sensors		
Key	Name	Specifications
03101185	SENSOR VC12 RT230106821 OFF DELAY	D = 6 mm, T = 5 s
03103678	SENSOR VC12 RT230106821 S3 D1	D = 3 mm, T = 1 s
03103660	SENSOR VC12 RT230106821 S3 D30	D = 3 mm, T = 30 s

Modular control unit

Excentric drop ass'y – Ø110 – 04905402

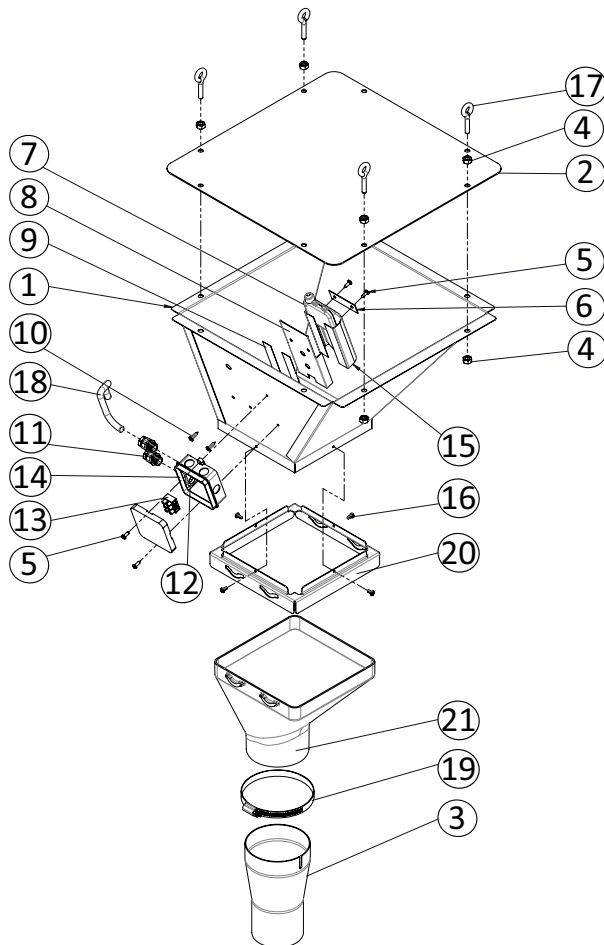

Key	Name	Part Nr.	Qt.
1	EXCENTRIC DROP - MODULAR CONTROL UNIT	14915938	1
2	COVER FUNNEL	14903553	1
3	REDUCTION PIECE Ø104.5-85 MM	00703074	1
4	NUT M8 DIN 934 - SP.	20200119	8
5	PARCKER SCREW 8 X 1/2"	20100525	4
6	SWITCH CONNECTION STRIP	13105259	1
7	SAFETY SWITCH ASS'Y	13104567	1
8	SWITCH SUPPORT	10203107	1
9	ADHESIVE TAPE 19X0.23-2SIDE	30800726	2
10	PARCKER SCREW 4.2 X 16 - DIN 7981 - A2	20102331	2
11	CABLE RING PG 9	15001472	2
12	CABLE RING HOLDER (2xPG9)	15010119	1
13	CLAMP STROKE 27 20 6E/3	10103109	1
14	HANDY BOX OBO A8	15000037	1
15	MINIMUM SWITCH SHIELD	10203115	1
16	PARCKER SCREW 4.2x9.5 DIN 7981FH	20103859	4
17	EYEBOLT M8X30	20100715	4
18	SWITCH CORD GUARD	13104369	1
19	HOSE CLAMP Ø90-110	00105726	1
20	CONNECTION PLATE FOR DROP	14915110	1
21	DROP FOR DROP TUBE Ø110	13702988	1

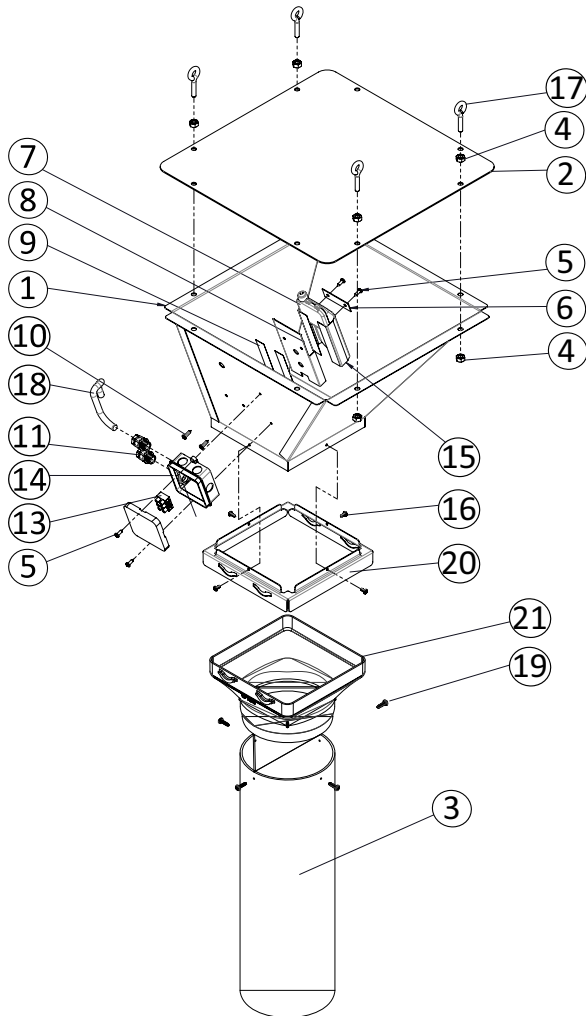
Excentric drop ass'y – Ø160 – 04918856

Key	Name	Part Nr.	Qt.
1	EXCENTRIC DROP - MODULAR CONTROL UNIT	14915938	1
2	COVER FUNNEL	14903553	1
3	TUBE Ø160 FOR DANCER ROLLER	11804684	1
4	NUT M8 DIN 934 - SP.	20200119	8
5	PARCKER SCREW 8 X 1/2"	20100525	4
6	SWITCH CONNECTION STRIP	13105259	1
7	SAFETY SWITCH ASS'Y	13104567	1
8	SWITCH SUPPORT	10203107	1
9	ADHESIVE TAPE 19X0.23-2SIDE	30800726	2
10	PARCKER SCREW 4.2 X 16 - DIN 7981 - A2	20102331	2
11	CABLE RING PG 9	15001472	2
12	CABLE RING HOLDER (2xPG9)	15010119	1
13	CLAMP STROKE 27 20 6E/3	10103109	1
14	HANDY BOX OBO A8	15000037	1
15	MINIMUM SWITCH SHIELD	10203115	1
16	PARCKER SCREW 4.2x9.5 DIN 7981FH	20103859	4
17	EYEBOLT M8X30	20100715	4
18	SWITCH CORD GUARD	13104369	1
19	PARCKER SCREW D.4.8X19-DIN7981-A2	20101747	4
20	CONNECTION PLATE FOR DROP	14915110	1
21	DROP Ø160 FOR EXTENSION BOOT	13000492	1

Extension modular control unit – FA 55 / FA 75 / FA 90 – 04904249

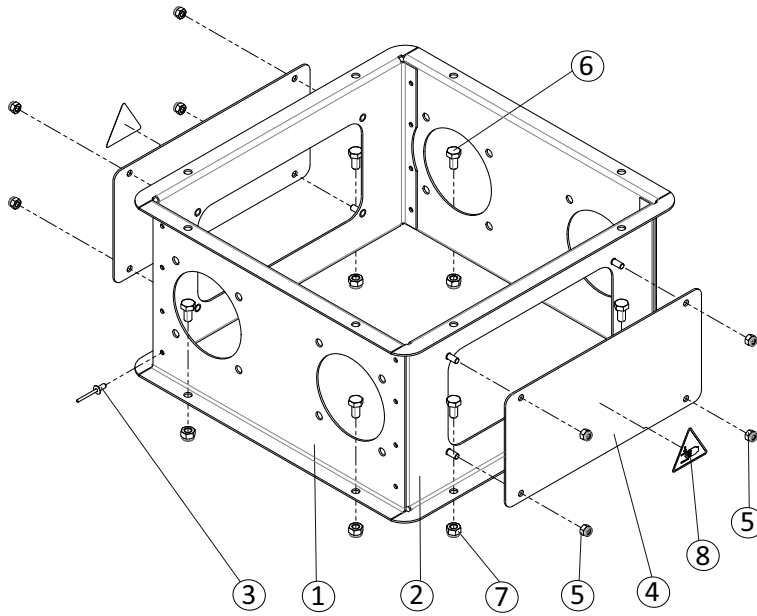

Key	Name	Part Nr.	Qt.
1	SIDE MODULAIRE CONTROL UNIT	14903686	2
2	FRONT & REAR MOD.CONTR.UN.	14903694	2
3	POP RIVET DIA 4.8X10-ALUMINIUM	20101085	16
4	CLOSING PLATE FOR CONTROL UNIT	14903546	2
5	LOCKNUT M6 - DIN 985	20100400	8
6	BOLT M8X16-DIN 933-8.8	20100228	8
7	LOCKNUT M8 - DIN 985	20100418	8
8	DECAL - HANDS WARNING	13106596	2

Extension modular control unit – FA 125 – 04909238

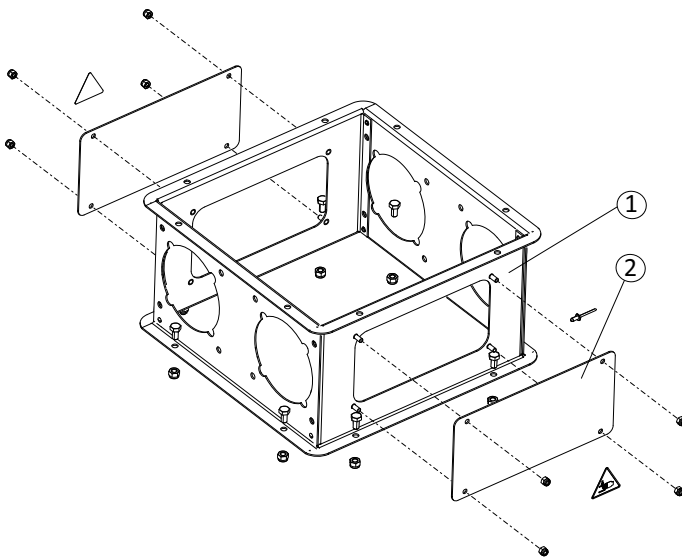

Key	Name	Part Nr.	Qt.
1	MOD. CONTR.UNIT(EXT.F/2 FA)125	14906076	1
2	CLOSING PLATE FOR CONTROL UNIT	14903546	2

Closing plate kit for modular control unit – FA 55 / FA 75 / FA 90 – 04904280

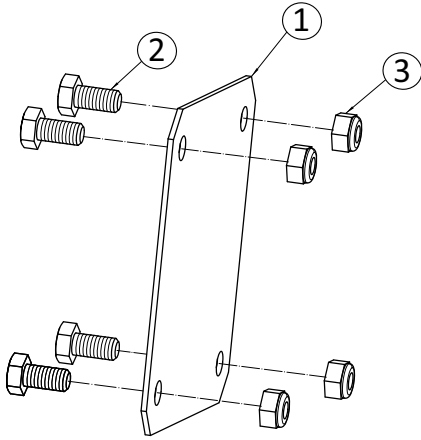

Key	Name	Part Nr.	Qt.
1	CLOSING PLATE KIT FOR MODULAR CONTR.UNIT	04904280	8
2*	BOLT M8X16 - DIN 933-8.8	20100228	2
3*	LOCKNUT M8 - DIN 985	20100418	8
*	INCLUDED IN 1		

Closing plate kit for modular control unit – FA 125 – 04909600

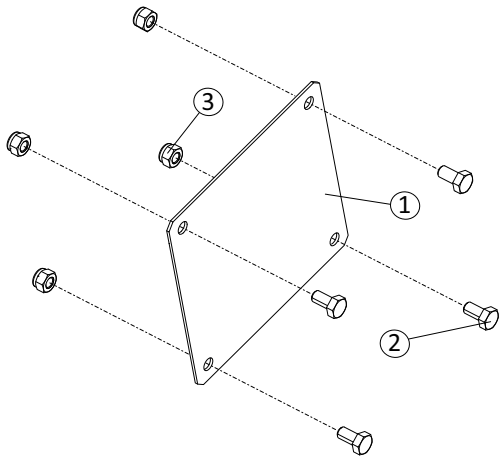

Key	Name	Part Nr.	Qt.
1	CLOSING PLATE F/MOD. CU125	14917816	1
2	BOLT M8X16-DIN 933-8.8	20100228	4
3	LOCKNUT M8 - DIN 985	20100418	4

Extension for intake boot

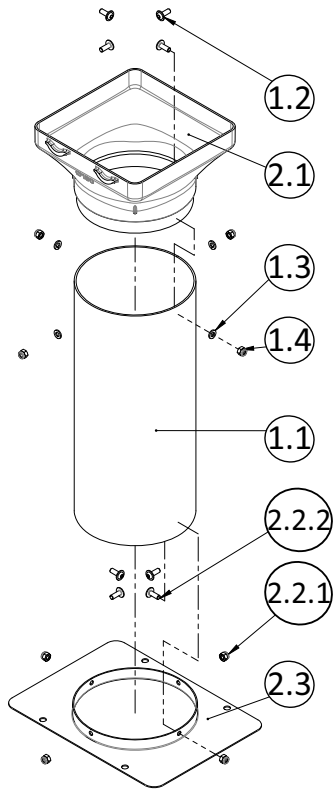

Key	Name	Part Nr.	Qt.
1	FEED BUFFER TUBE	04801973	1
1.1	TUBE Ø160X370	14802698	1
1.2	BUT.HEAD CAP SCREW W/FLANGE M6x16-A2	20109146	4
1.3	WASHER DIA.6.4x12x1.6 - DIN125 - A2	20103081	4
1.4	LOCKNUT M6 - DIN 985 -A2	20101960	4
2	DISCAFLEX INTAKE 360° ST.ST.	04801924	1
2.1	DROP Ø160 FOR EXTENSION BOOT	13000492	1
2.2	HW KIT F/ FA EXTENSION 360°	13000518	1
2.2.1	LOCKNUT M6 - DIN 985 -A2	20101960	4
2.2.2	BUT.HEAD CAP SCREW W/FLANGE M6x16-A2	20109146	4
2.3	EXTENSION PLATE Ø160 GALVA	13109525	1
*	EXTENSION PLATE Ø160 ST.ST.	13109541	1
*	OPTION		

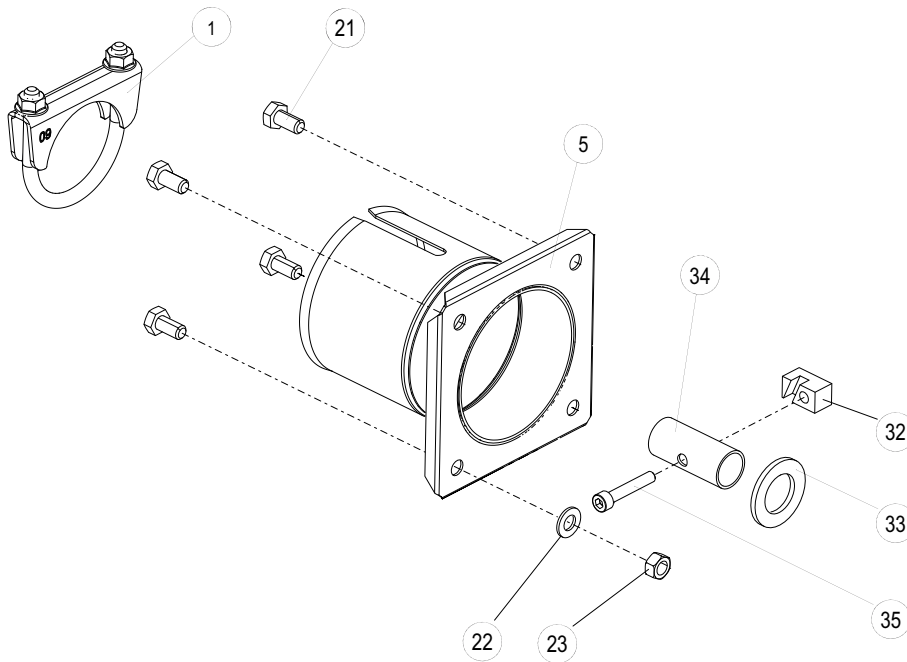
Connection kit for modular control unit FA 55 - 04904736

Key	Name	Part Nr.	Qt.
1	TUBE CLAMP Ø60	13000021	1
5	TUBE ANCHOR WELDMENT	13501747	1
*21	BOLT M8X16 - DIN 933-8.8	20100228	8
*22	WASHER Ø9XØ17X1.6 - DIN 126	20100467	4
*23	NUT M8 - DIN 934	20200028	4
*32	DRIVE BLOCK	10100782	1
*33	GALV.WASHER Ø39X23X3	20103842	1
*34	DRIVE TUBE	13500434	1
*35	SOCKET CAP SCREW M6X35 DIN 912	20102158	1
*47	PARCKER SCREW 8X1/2"	20100525	4
*48	WASHER 4.3X9X0.8	20100566	4
*	HARDWARE KIT	13501689	1

Connection kit for modular control unit FA 75 - 04904744

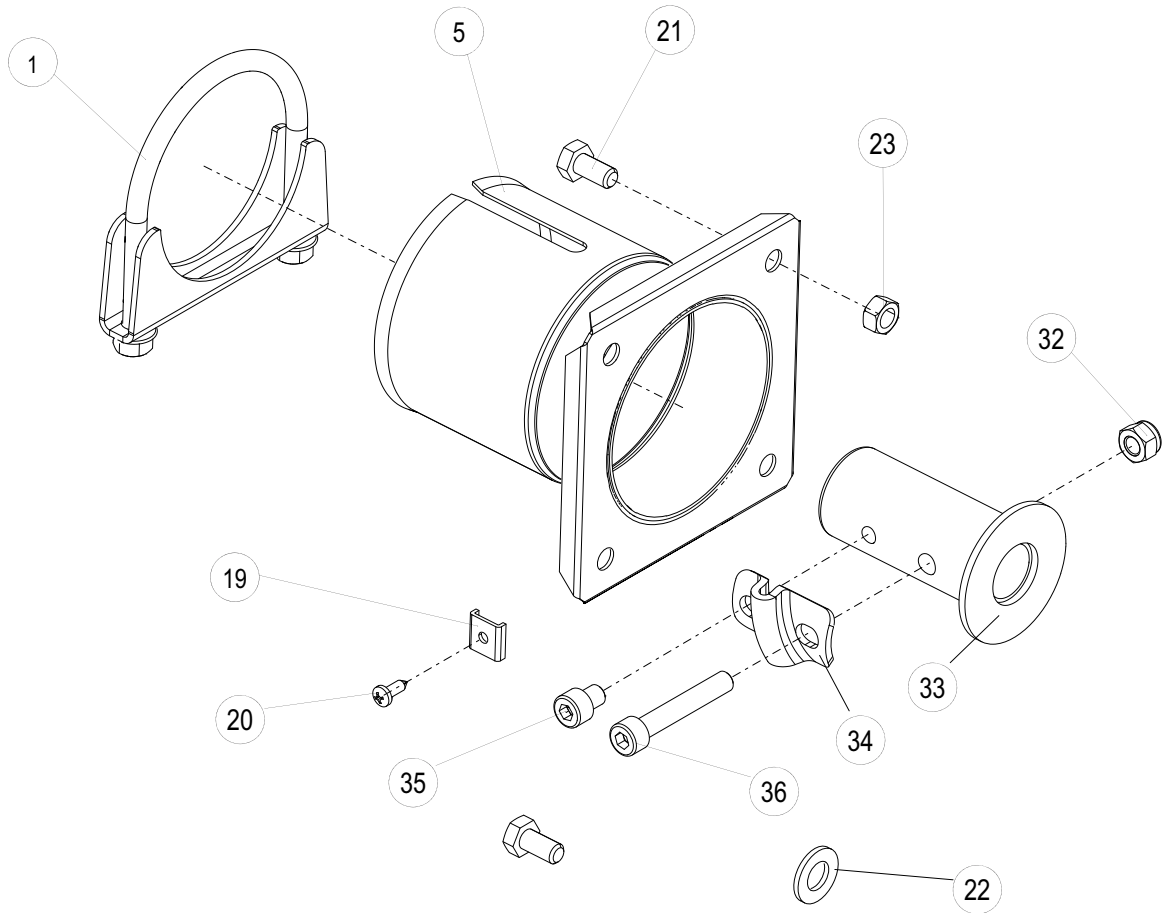

Key	Name	Part Nr.	Qt.
1	TUBE CLAMP ASSEMBLY Ø80MM	03900065	1
5	TUBE ANCHOR WELDMENT	13107701	1
*19	BOW CLAMP	13103643	6
*20	PARCKER SCREW 8X1/2"	20100525	6
*21	BOLT M8X16 - DIN 933-8.8	20100228	8
*22	WASHER Ø9XØ16X1.6 - DIN 126	20100467	4
*23	NUT M8 - DIN 934	20200028	4
*32	LOCKNUT M8 - DIN 985	20100418	1
33	DRIVER WELDMENT	13105200	1
*34	ANCHOR CLAMP	13104575	1
*35	SOCKET CAP SCREW M8X10 - DIN 912	20102778	1
*36	SOCKET CAP SCREW M8X50 - DIN 912	20102786	1
*	HARDWARE KIT	13106612	1

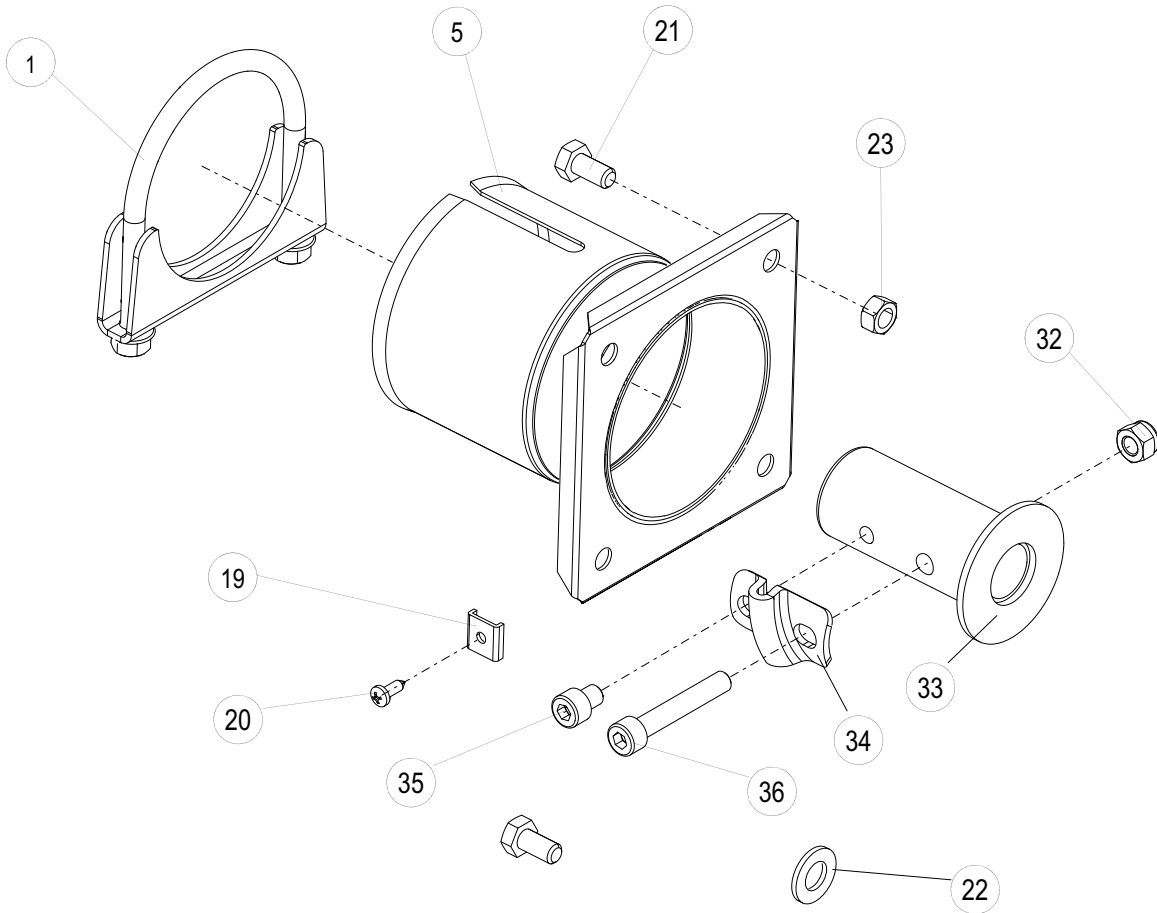
Connection kit for modular control unit FA 90 - 04904751

Key	Name	Part Nr.	Qt.
1	TUBE CLAMP ASSEMBLY Ø95MM	03200029	1
5	TUBE ANCHOR WELDMENT	13200308	1
*19	BOW CLAMP	13103643	6
*20	PARCKER SCREW 8X1/2"	20100525	6
*21	BOLT M8X16 - DIN 933-8.8	20100228	8
*22	WASHER Ø9XØ17X1.6 - DIN 126	20100467	4
*23	NUT M8 - DIN 934	20200028	4
*32	LOCKNUT M8 - DIN 985	20100418	1
33	DRIVER WELDMENT	13201561	1
*34	ANCHOR CLAMP	13104575	1
*35	SOCKET CAP SCREW M8X10 - DIN 912	20102778	1
*36	SOCKET CAP SCREW M8X50 - DIN 912	20102786	1
*	HARDWARE KIT	13106612	1

Connection kit for modular control unit FA 125 - 04904759

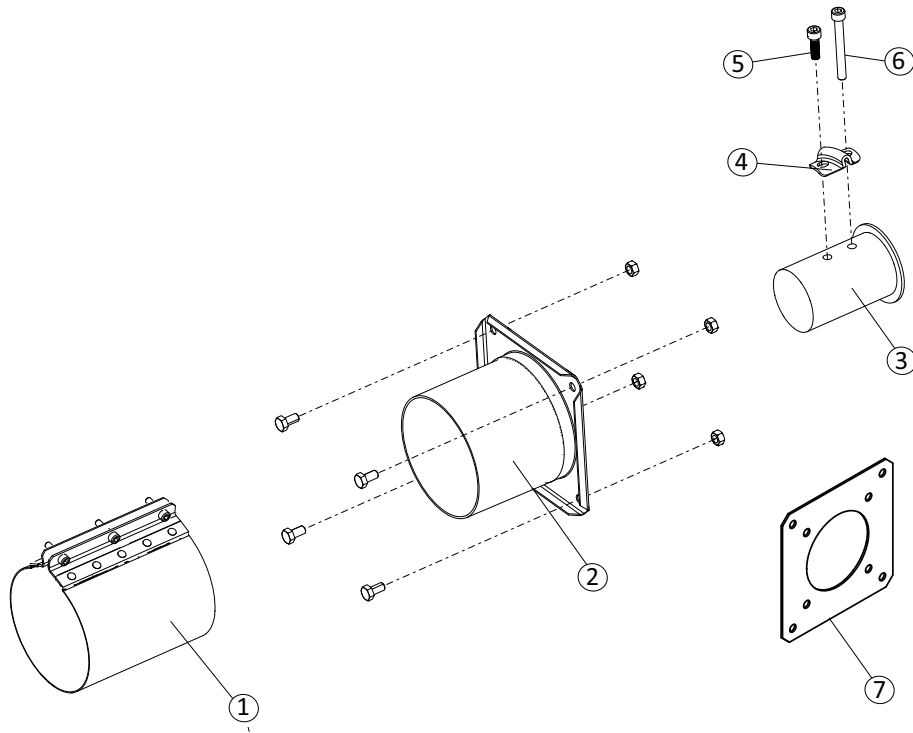

Key	Name	Part Nr.
1	TUBE CONNECTOR KIT	03700382
2	TUBE ANCHOR WELDMENT	13701412
3	DRIVER WELDMENT	13700349
4	ANCHOR CLAMP	13104575
5	SOCKET CAP SCREW M8 X 25 - DIN 912	20101978
6	SOCKET CAP SCREW M8 X 70 - DIN 912	20101986
7	ADAPTION PLATE - 125	13701396

Subtypes Flex-Auger system

Overhead system

General view overhead system

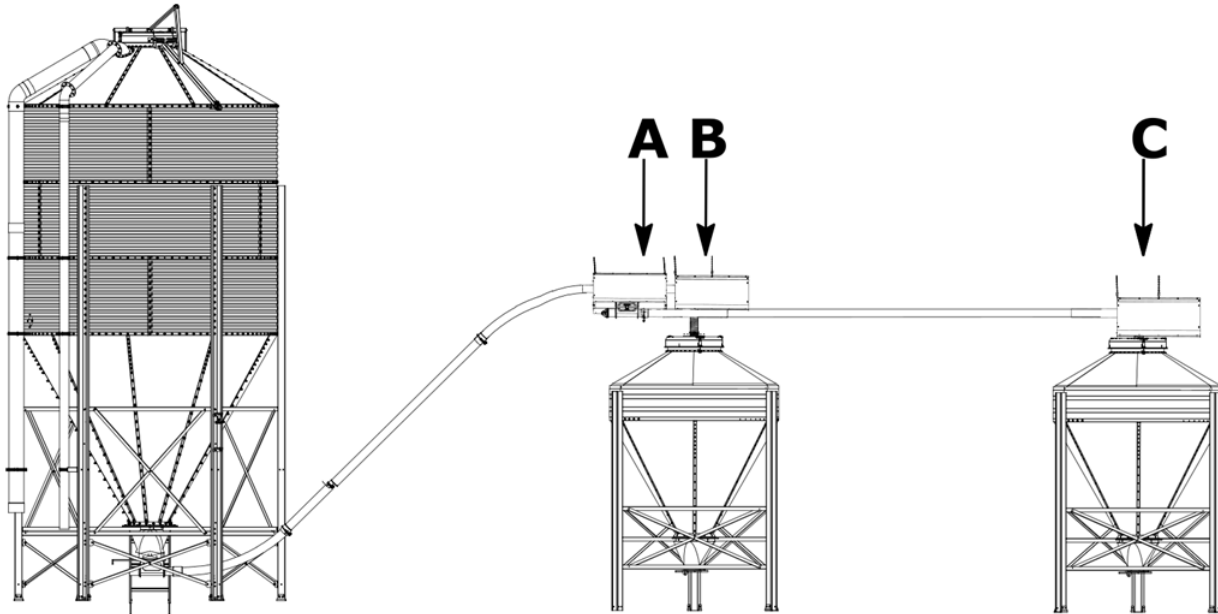

Motor cover mounting kit $\varnothing 90$ - 03000900

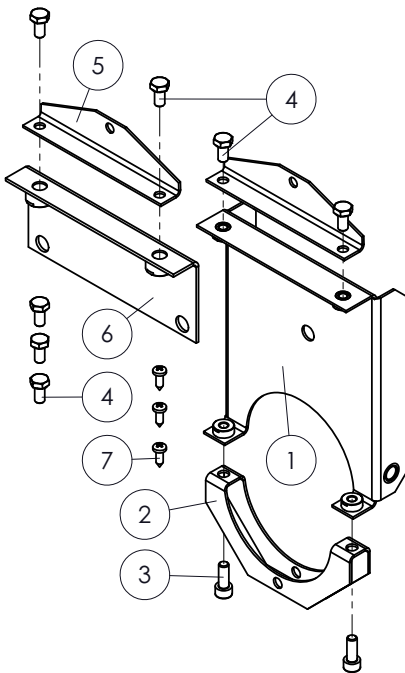

Key	Name	Part Nr.	Qt.
1	COVER HOLDER - LONG $\varnothing 90$	13008115	1
2	TUBE CLAMP HALF DIA. 90 FRONT	14900906	1
3	SOCKET CAP SCREW M6 x 16 - DIN 912	20101812	2
4	BOLT M6 X 12 - DIN 933-8.8	20100160	24

Key	Name	Part Nr.	Qt.
5	COVER SUSPENSION PLATE	13000666	2
6	COVER HOLDER - SHORT	13000641	1
7	PARCKER SCREW 8 X 1/2"	20100525	3

Motor cover mounting kit ϕ 125 - 03001219

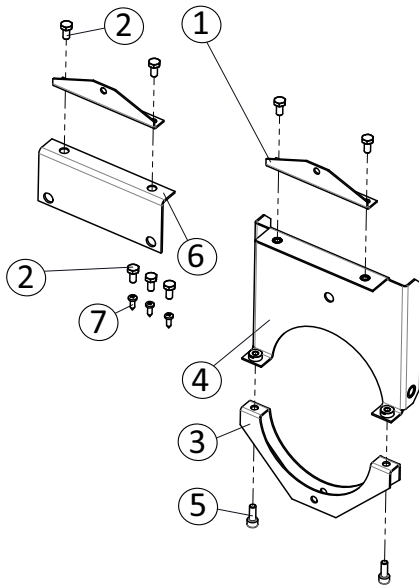

Key	Name	Part Nr.	Qt.
1	COVER SUSPENSION PLATE	13000666	2
2	BOLT M6 X 12 - DIN 933-8.8	20100160	24
3	TUBE CLAMP HALF DIA. 125 FRONT	13703196	1
4	COVER HOLDER - LONG ϕ 125	13703060	1
5	SOCKET CAP SCREW M6 x 16 - DIN 912	20101812	2
6	COVER HOLDER - SHORT	13000641	1
7	PARCKER SCREW 8 X 1/2"	20100525	3

Cover Flex-Auger fill system – 15902513

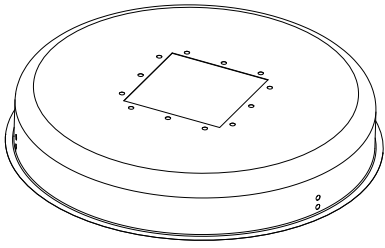

Motor cover - top plate - 03000902

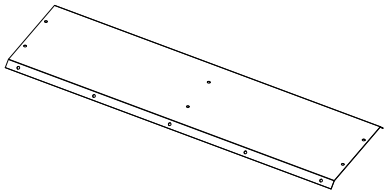

Motor cover - side plate - 03000904

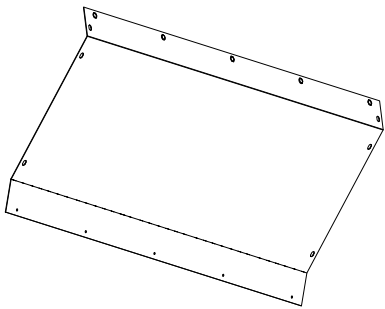

Extension boot cover mounting kit - Ø90 - 03000906

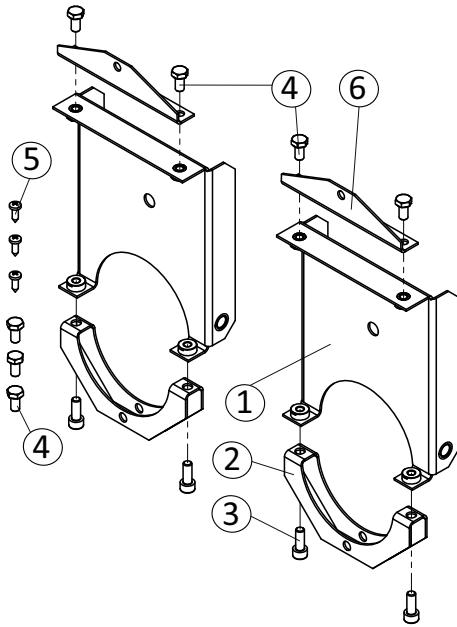

Key	Name	Part Nr.	Qt.
1	COVER HOLDER - LONG Ø90	13008115	2
2	TUBE CLAMP HALF Ø90 FRONT	14900906	2
3	SOCKET CAP SCREW M6 x 16 - DIN 912	20101812	4
4	BOLT M6 X 12 - DIN 933-8.8	20100160	24
5	PARCKER SCREW 8 X 1/2"	20100525	3
6	COVER SUSPENSION PLATE	13000666	2

Extension boot cover mounting kit - Ø125 - 03001227

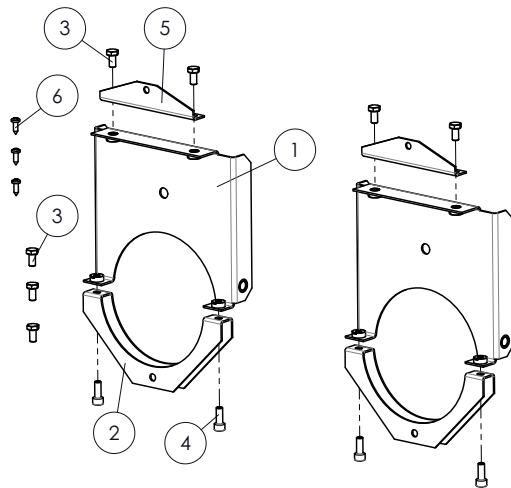

Key	Name	Part Nr.	Qt.
1	COVER HOLDER - LONG Ø125	13703060	2
2	TUBE CLAMP HALF DIA. 125 FRONT	13703196	2
3	BOLT M6 X 12 - DIN 933-8.8	20100160	7
4	SOCKET CAP SCREW M6 x 16 - DIN 912	20101812	4
5	COVER SUSPENSION PLATE	13000666	2
6	PARCKER SCREW 8 X 1/2"	20100525	3

Motor cover – front plate left – Ø90 – 03000894



Motor cover – front plate right – Ø90 – 03000896



Motor cover – front plate left – Ø125 – 03701204

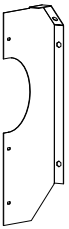

Motor cover – front plate right – Ø125 – 03701220

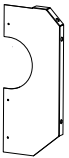

Connection control unit to bin – suspended – 03000874

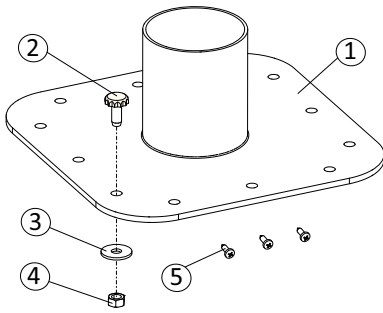

Key	Name	Part Nr.	Qt.
1	ROUND CONNECTOR - WELDED	13000690	1
2	BOLT M8X20 WITH RUBBER CAP	16103152	12
3	WASHER Ø8.4X25X2 - DIN 9021	20102794	12
4	NUT M8 - DIN 934	20200028	12
5	PARCKER SCREW 8X1/2"	20100525	3

Connection control unit to bin – fixed – 03000866

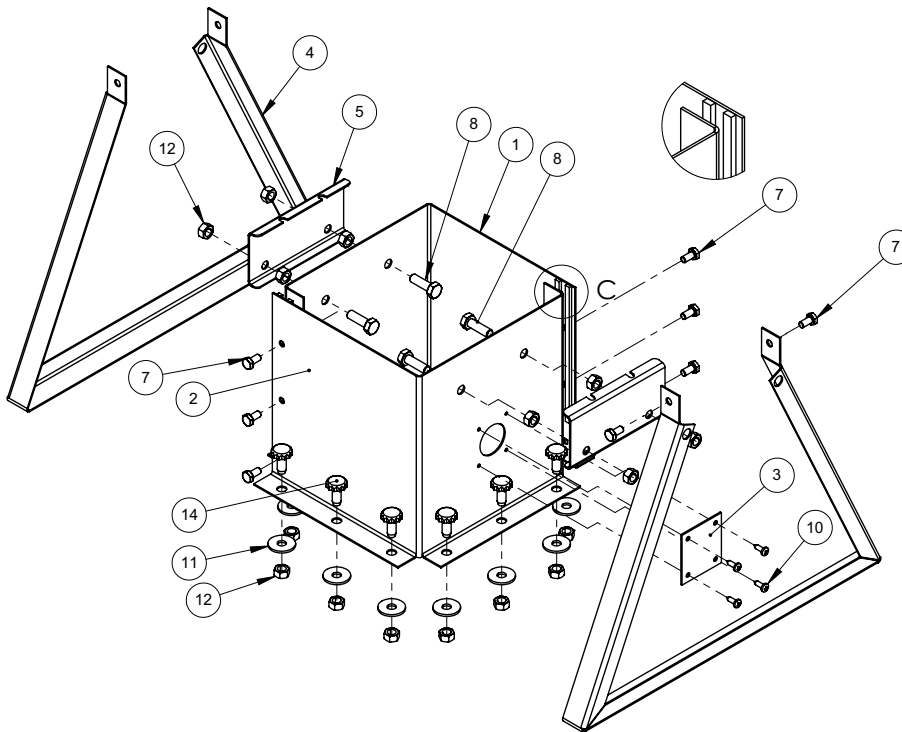

Key	Name	Part Nr.	Qt.
1	CONNECTION PLATE	13000674	1
2	CONNECTION PLATE WITH HOLE	13000682	1
3	SEALING PLATE FOR SENSOR	13000708	1
4	TRIANGULAR MOTOR SUPPORT	13000732	2
5	CLAMP PLATE FOR TRANSFER PIECE	13203906	2
6	BOLT M8X20 WITH RUBBER CAP	16103152	12
7	BOLT M6X12 - DIN 933-8.8	20100160	8
8	BOLT M8X25 - DIN 933-8.8	20100236	4
10	PARCKER SCREW 8X1/2"	20100525	4
11	WASHER Ø8.4X25X2 - DIN 9021	20102794	12
12	NUT M8 - DIN 934	20200028	20

Extension boot for overhead FA 90 – 03202678

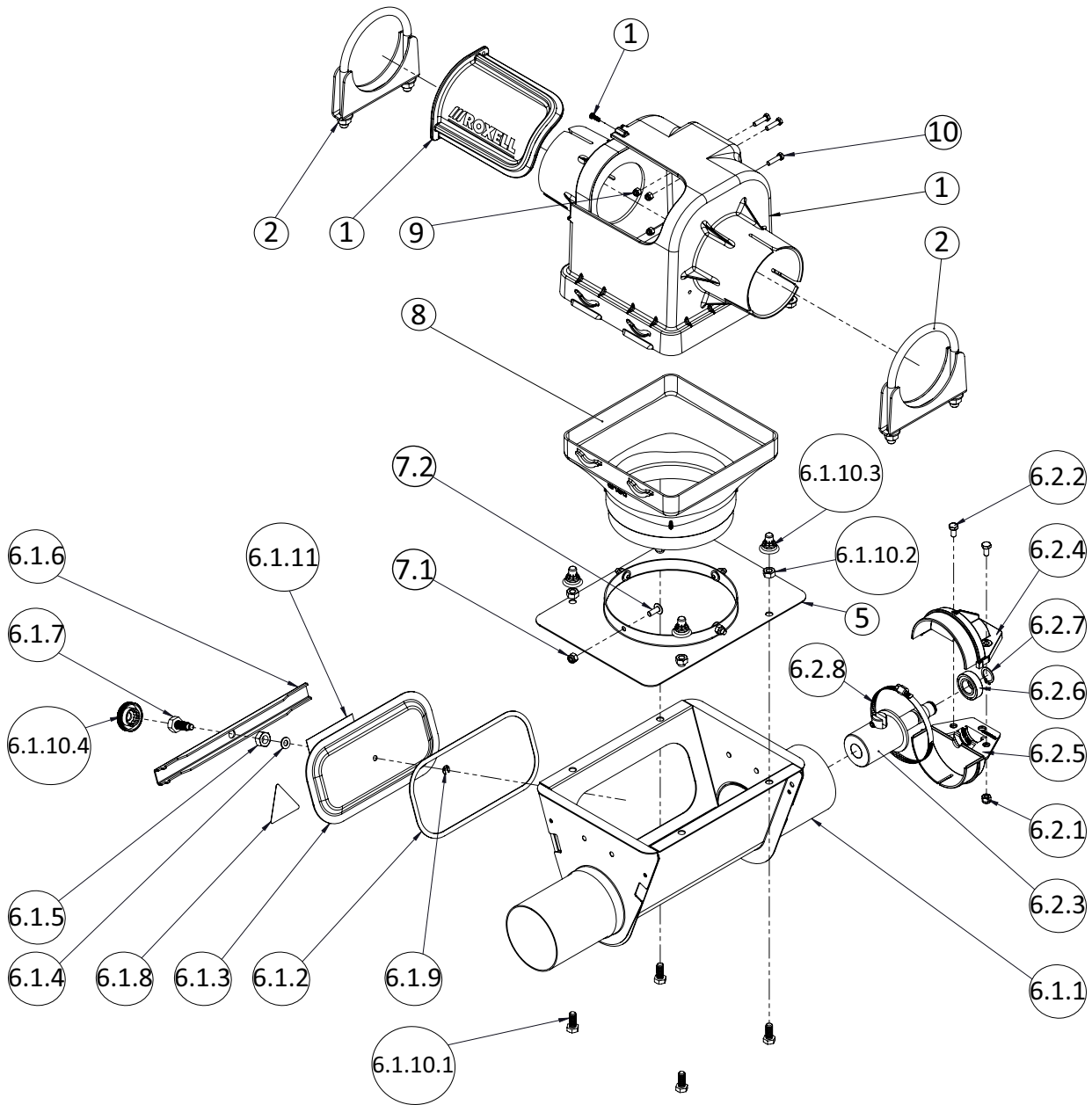

Key	Name	Part Nr.	Qt.
1	HOUSING+WINDOW ASS'Y	13000831	1
2	TUBE CLAMP ASSEMBLY Ø100MM	03202561	2
5	EXTENSION PLATE Ø160 GALVA	13109525	1
6	BOOT ASS'Y FA90 FOR EXT.Boot	13203963	1
6.1	INTAKE BOOT & CLOSING PLATE FA90	13204003	1
6.1.1	BOOT BODY WELDMENT FA 90	13202965	1
6.1.2	GASKET 15 x 2	30800874	1
6.1.3	CLOSING PLATE	13107776	1
6.1.4	FIBER RING	20104287	1
6.1.5	NUT M10-DIN 934	20100277	1
6.1.6	CLOSING PROFILE	13107768	1
6.1.7	CLOSING BOLT - BRASS SMAL	13108154	1
6.1.8	DECAL - HANDS WARNING	13106596	1
6.1.9	E-RING DIA.5-DIN 6799-S.S	20102018	1
6.1.10	HARDWARE KIT EXTENSION BOOT	13000526	1

Key	Name	Part Nr.	Qt.
6.1.10.1	BOLT M8X20-DIN 933-8.8	20200150	4
6.1.10.2	NUT M8 DIN 934 - SP.	20200119	4
6.1.10.3	RUBBER CAP M 8	16103699	4
6.1.10.4	KNURLED KNOB	13107842	1
6.1.11	DECAL - ROXELL 73x18	10102697	1
6.2	ANCHOR & BEARING ASS'Y FA90	13204037	1
6.2.1	LOCKNUT M6 - DIN 985	20100400	2
6.2.2	BOLT M6 X 12 - DIN 933-8.8	20100160	2
6.2.3	ANCHOR TUBE WELDMENT DIA.44	13204045	1
6.2.4	BEARING HOLDER CAP UP - DIA.90	13203781	1
6.2.5	BEARING HOLDER CAP DOWN-DIA.90	13203799	1
6.2.6	BEARING 17 X 35 X 10 - 6003 LLU	13201066	1
6.2.7	SEEGER RING DIA. 17 X 1	20101333	1
6.2.8	HOSE CLAMP ø80-100	03200250	1
7	HW KIT F/ FA EXTENSION 360°	13000518	1
7.1	LOCKNUT M6 - DIN 985 -A2	20101960	4
7.2	BUT.HEAD CAP SCREW W/FLANGE M6x16-A2	20109146	4
8	DROP ø160 FOR EXTENSION BOOT	13000492	1
9	LOCKNUT M5-DIN 985	20100392	3
10	BOLT M5X20-DIN 933-8.8	20100137	3

Extension boot for overhead FA 125 – 03701228

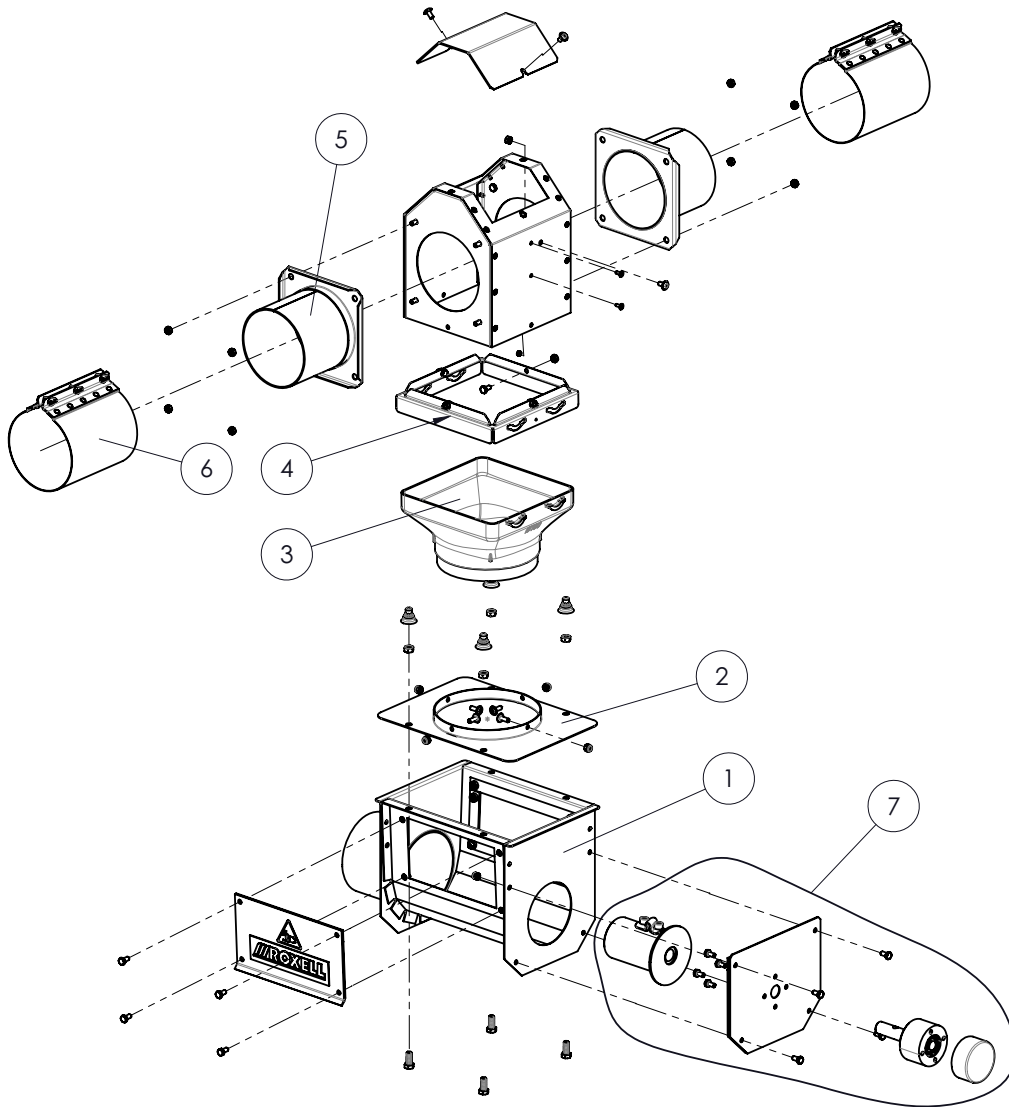

Key	Name	Part Nr.
1	BOOT ASSEMBLY FA 125	03702141
2	EXTENSION PLATE Ø160 GALVA	13109525
3	DROP Ø160 FOR EXTENSION BOOT	13000492
4	CONNECTION PLATE F/DROP	14916098
5	TUBE ANCHOR WELDMENT Ø125	14916527
6	TUBE CONNECTOR KIT	03700382
7	ANCHOR + BEARING ASS'Y FA125	13701016

CDS system

General view CDS system

 NOTE: CDS = Circular Distribution System

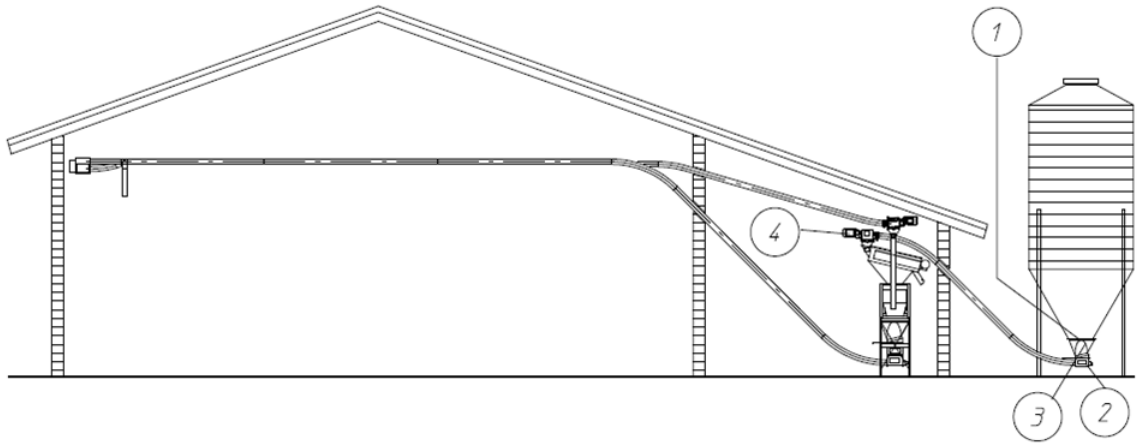

Standard – FA 75/90/125

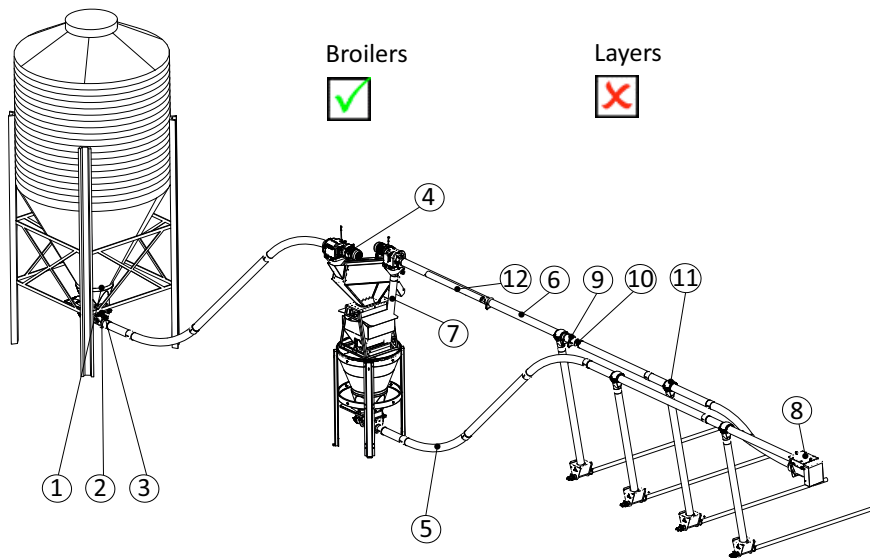

Broiler cages – FA 90/125

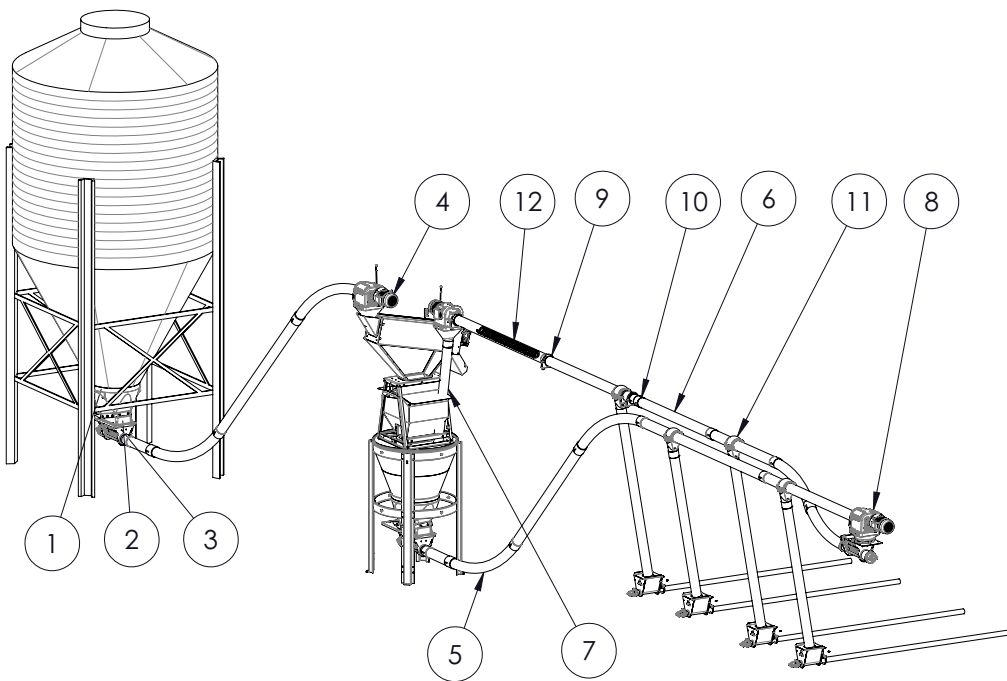
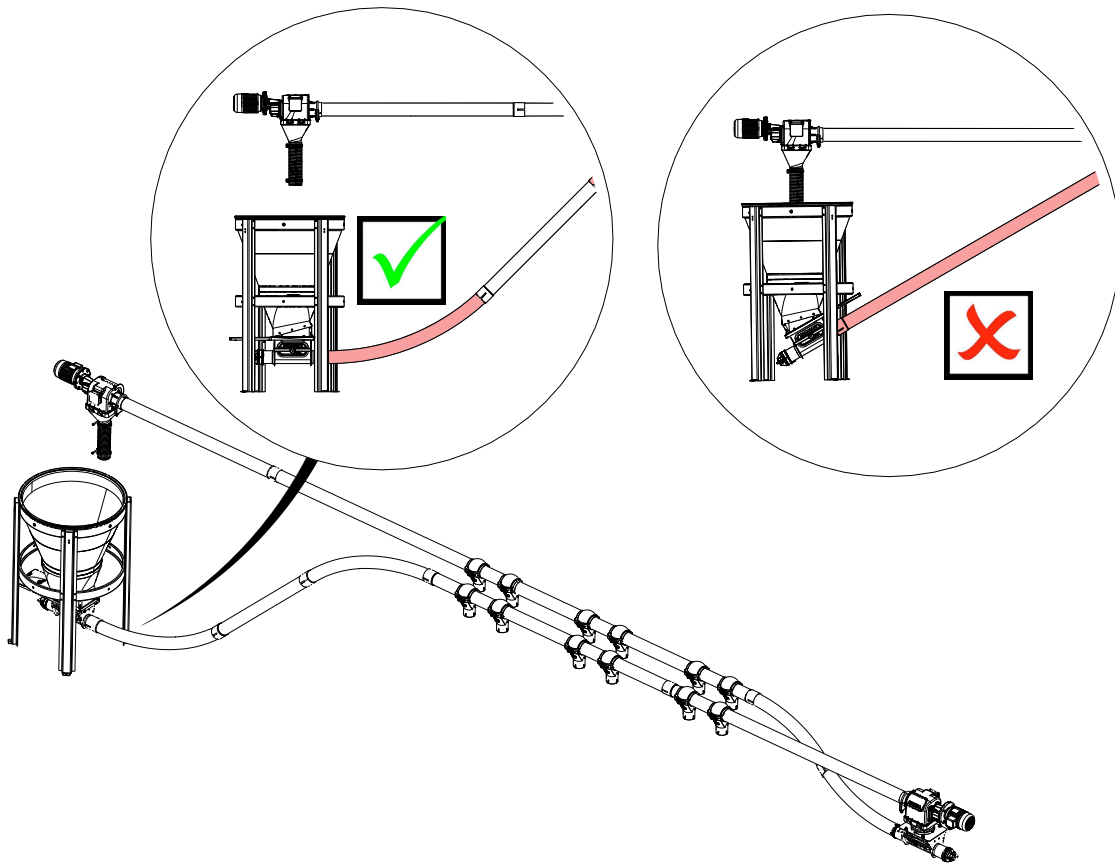

Component numbers

Key	Name	Number		
		Mod. 75	Mod. 90	Mod. 125
1	UNIVERSAL COLLAR	03102001	03102001	03102001
2	BOOT ASSEMBLY	03103850	03202629	03702141
3	UPPER BOOT 15° PE BLACK	03000577	03000577	03000577
4	POWER UNIT		See Power unit.	
5	NOVICOR ELBOW 45°	03100542	03200326	03700051
	HARDENED STEEL ELBOW 45°	-	03200433	03700002
6	NOVICOR TUBE - 3 M	03100559	03200300	03700069
	METAL TUBE - 3 M	-	03200102	03700200
	PLASTIC DROP TUBE Ø85 MM - 2.5 M	-	03100625	03100625
7	RETURN BOX FOR CDS	03102977	03202025	-
*8	EXTENSION BOOT	03103884	03202652	03700853
9	TUBE CLAMP ASSY	-	03200029	03700077
	HOSE CLAMP	03100658	03200250	03701196
	HOSE CLAMP Ø131-139MM W/SCREWS			03702125
10	TUBE CONNECTOR KIT	03200169	03200169	03700382
	TUBE CONNECTOR	03100583	03200383	03700382
11	OUTLET DROP ASS'Y W/SHUT- OFF	See Outlet drop ass'y w/shut-off model 55, 75, 90 and 125.		
12	AUGER	03100187	03200409	03700085

Tandem system

Tandem in line FA 75 - 03103876

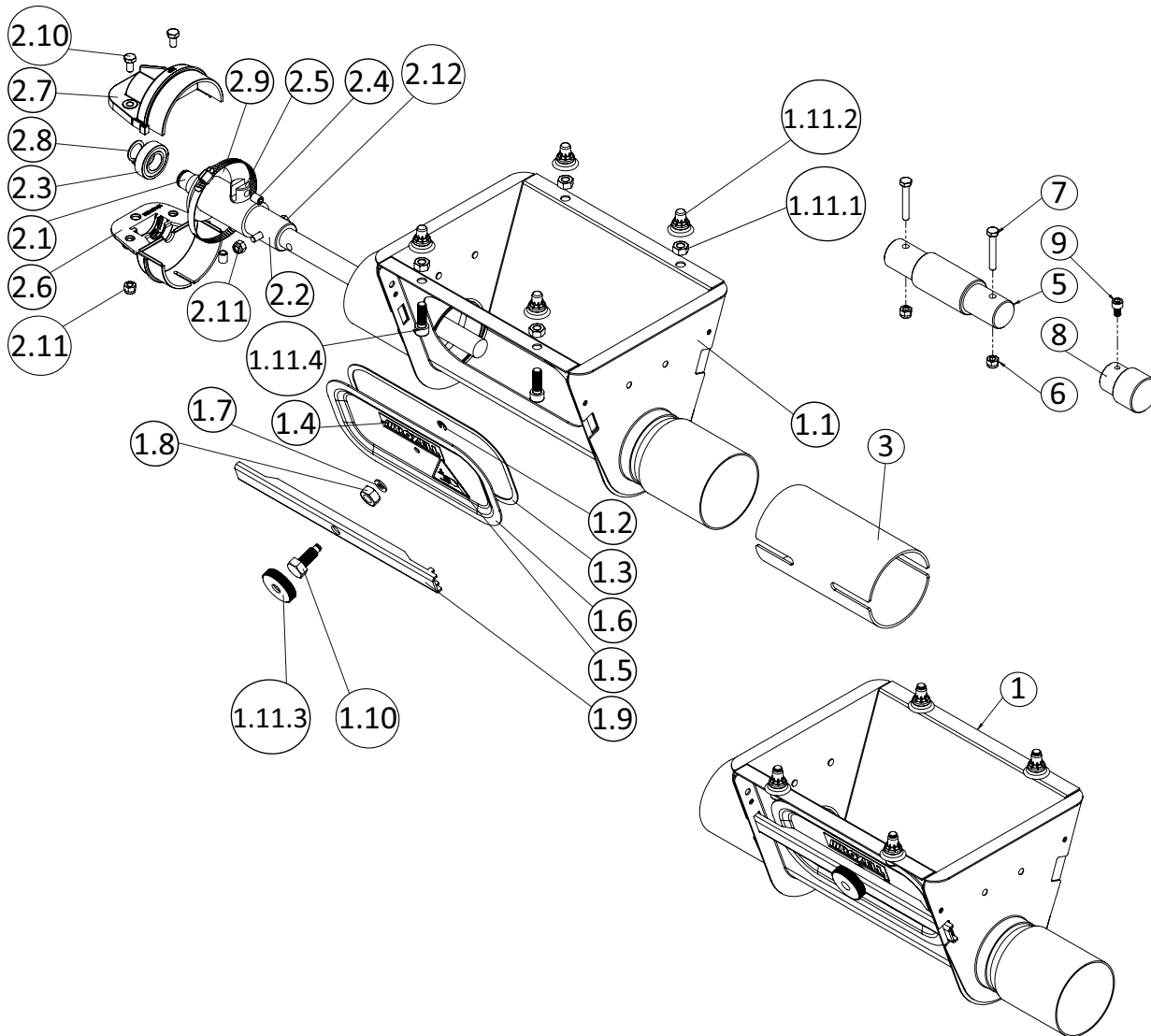

Key	Name	Part Nr.	Qt.
1	INTAKE BOOT & CLOSING PLATE	13108022	2
1.1	BOOT BODY WELDMENT FA 75	13108030	1
1.2	E-RING Ø5-DIN 6799-A2 S.S	20102018	1
1.3	GASKET 15X2	30800874	1
1.4	DECAL - ROXELL 73x18	10102697	1
1.5	DECAL - HANDS WARNING	13106596	1
1.6	CLOSING PLATE	13107776	1
1.7	FIBER RING	20104287	1
1.8	NUT M10 - DIN 934	20100277	1
1.9	CLOSING PROFILE	13107768	1
1.10	CLOSING BOLT - BRASS SMAL	13108154	1
1.11	HARDWARE KIT	13108055	1
1.11.1	NUT M8 DIN 934 - SP	20200119	4
1.11.2	SEAL CAP M8	16103699	4
1.11.3	KNURLED KNOB	13107842	1
1.11.4	SOCKET CAP SCREW M8X25 - DIN 912	20101978	4
2	ANCHOR & BEARING ASS'Y FA75	13109796	1
2.1	ANCHOR&BEARING SHAFT FA75-90	13109780	1

Key	Name	Part Nr.	Qt.
2.2	ANCHOR TUBE WELDMENT DIA.36	13109788	1
2.3	BEARING 17X35X10 - 6003 LLU	13201066	1
2.4	SET SCREW M8X10 - DIN 916	20100434	2
2.5	CLAMP PIN	13100482	1
2.6	BEARING HOLDER CAP DOWN - Ø75	13109632	1
2.7	BEARING HOLDER CAP UP - Ø75	13109624	1
2.8	SEEGER RING Ø17X1	20101333	1
2.9	HOSE CLAMP ASSEMBLY Ø70-90	03100658	1
2.1	BOLT M6X12 - DIN 933-8.8	20100160	2
2.11	LOCKNUT M6 - DIN 985	20100400	3
2.12	BOLT M6X40 - DIN 931-8.8	20100558	1
3	TUBE CONNECTOR Ø75MM	03100583	1
5	COUPLING FOR TUBE Ø32x1.2MM	13109812	1
6	LOCKNUT M6 - DIN 985	20100400	2
7	BOLT M6X40 - DIN 931-8.8	20100558	2
8	GUIDE PIECE F/ RESTR.TUBE FA75	13109160	1
9	SOCKET CAP SCREW M6X10 - DIN 912	20101713	1

Tandem in line FA 90 - 03202645

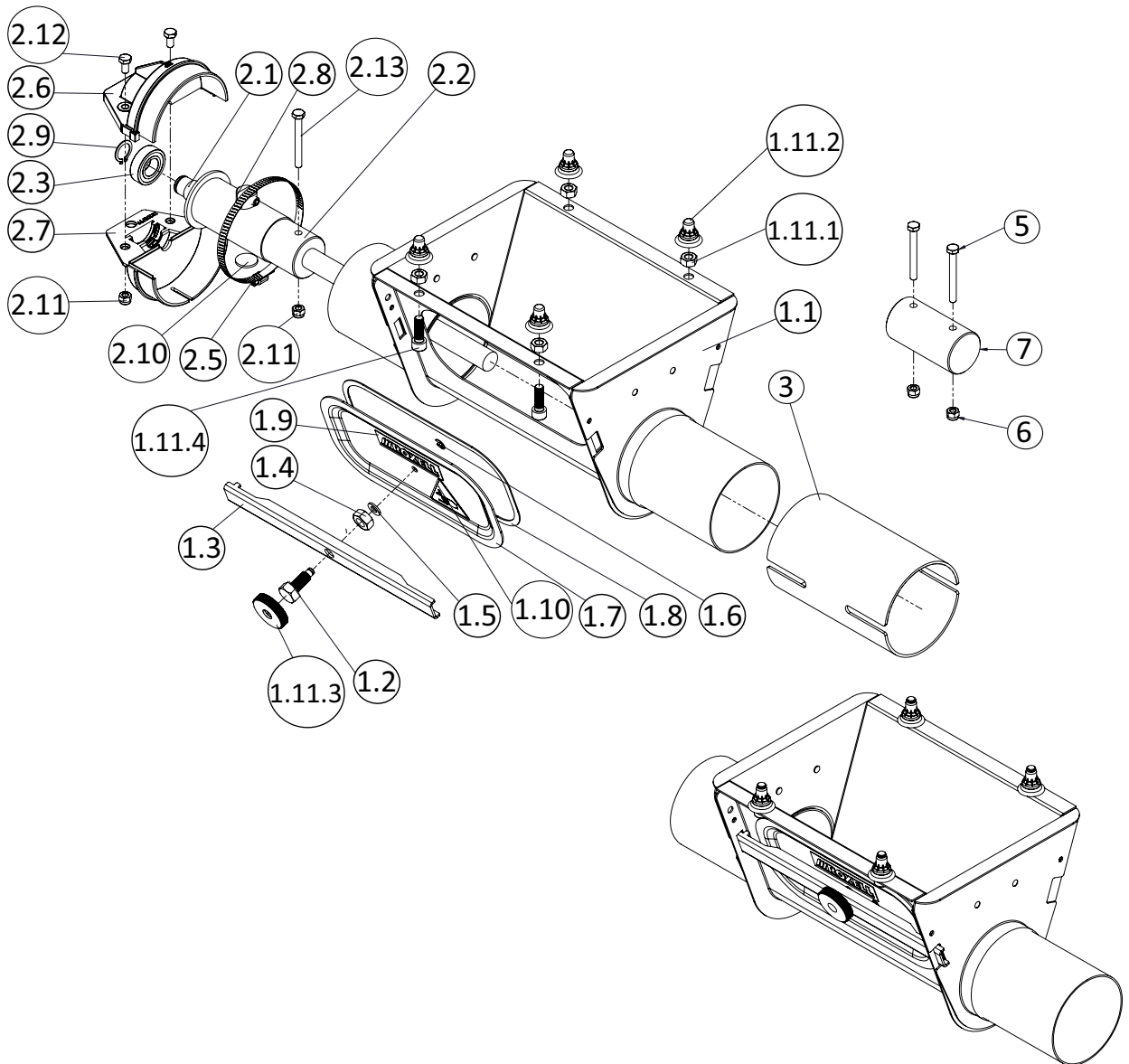

Key	Name	Part Nr.	Qt.
1	INTAKE BOOT & CLOSING PLATE FA90	13202957	2
1.1	BOOT BODY WELDMENT FA 90	13202965	1
1.2	CLOSING BOLT - BRASS SMAL	13108154	1
1.3	CLOSING PROFILE	13107768	1
1.4	NUT M10 - DIN 934	20100277	1
1.5	FIBER RING	20104287	1
1.6	E-RING Ø5-DIN 6799-A2 S.S	20102018	1
1.7	CLOSING PLATE	13107776	1
1.8	GASKET 15X2	30800874	1
1.9	DECAL - ROXELL 73x18	10102697	1
1.1	DECAL - HANDS WARNING	13106596	1
1.11	HARDWARE KIT	13108055	1
1.11.1	NUT M8 DIN 934 - SP	20200119	4
1.11.2	SEAL CAP M8	16103699	4
1.11.3	KNURLED KNOB	13107842	1
1.11.4	SOCKET CAP SCREW M8X25 - DIN 912	20101978	4
2	ANCHOR & BEARING ASS'Y FA90	13204092	1
2.1	ANCHOR & BEARING SHAFT FA75-90	13109780	1
2.2	ANCHOR TUBE WELDMENT DIA.44	13204100	1
2.3	BEARING 17X35X10 - 6003 LLU	13201066	1
2.4	SET SCREW M8X10 - DIN 916	20100434	2
2.5	HOSE CLAMP Ø80 - 100MM	03200250	1
2.6	BEARING HOLDER CAP UP - Ø90	13203781	1
2.7	BEARING HOLDER CAP DOWN - Ø90	13203799	1
2.8	CLAMP PIN	13100482	1
2.9	SEEGER RING Ø17X1	20101333	1
2.1	SPACER	13200134	2
2.11	LOCKNUT M6 - DIN 985	20100400	3
2.12	BOLT M6X12 - DIN 933-8.8	20100160	2
2.13	BOLT M6X55 DIN 931-GALV.	20101309	1
3	TUBE CONNECTOR Ø90MM	03200383	1
5	BOLT M6X55 DIN 931-GALV.	20101309	2
6	LOCKNUT M6 - DIN 985	20100400	2
7	COUPLING FOR TUBE Ø44.5X1MM	13204116	1

Tandem in line FA 125 - 03700580

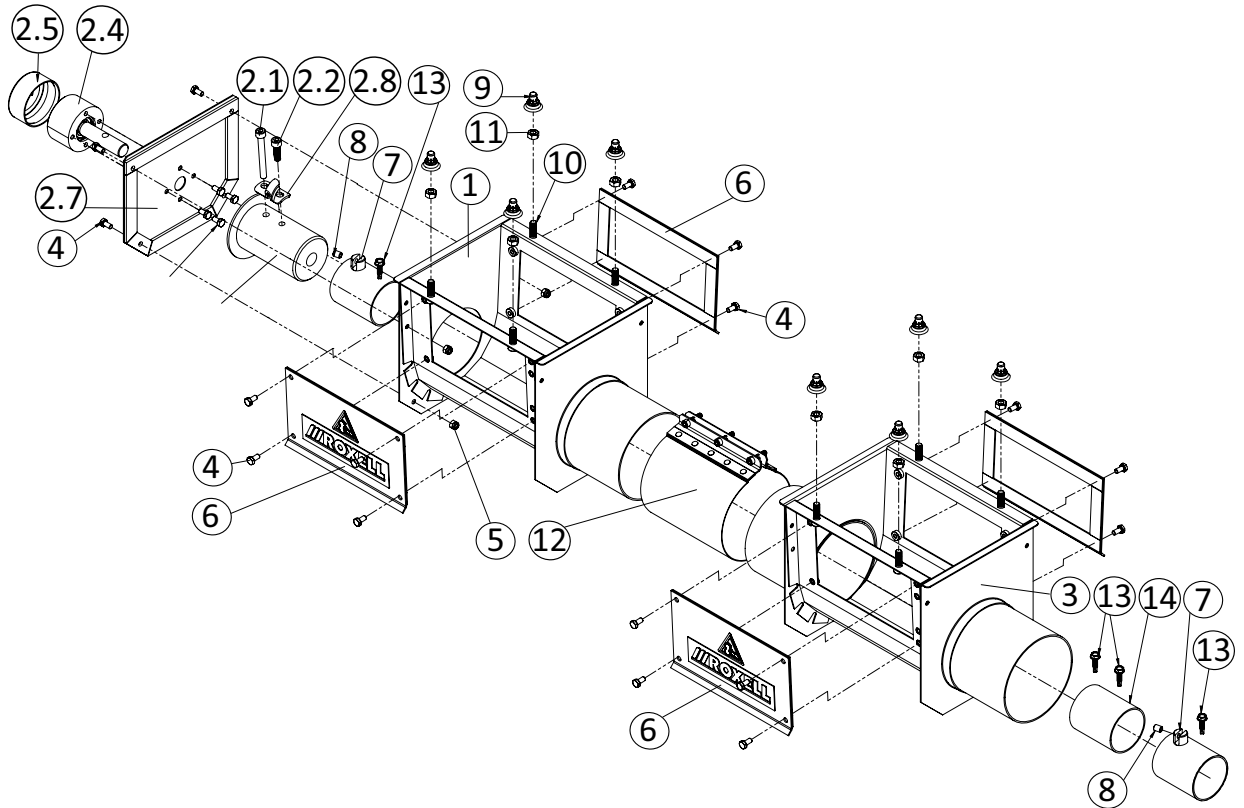

Key	Name	Part Nr .	Qt.
1	BOOT BODY WELDMENT	13701081	1
2	ANCHOR + BEARING ASS'Y FA 125	13701016	1
2.1	SOCKET CAP SCREW M8X70 - DIN 912	20101986	1
2.2	SOCKET CAP SCREW M8X25 - DIN 912	20101978	1
2.3	BOLT M6X12 - DIN 933-8.8	20100160	4
2.4	FRONT PLATE DRIVER ASS'Y FA 125	13701115	1
2.5	CAP Ø63.5	13701131	1
2.6	ANCHOR WELDMENT FA 125	13700984	1
2.7	FLANGE WITH GASKET	13701289	1
2.8	ANCHOR CLAMP	13104575	1
3	BOOT BODY WELDMENT	13701339	1
4	BOLT M6X12 - DIN 933-8.8	20100160	20
5	LOCKNUT M6 - DIN 985	20100400	4
6	CLOSING PLATE ASS'Y	13102629	4
7	RESTRICTOR WELDMENT	13701263	2
8	SET SCREW M8X10 - DIN 916	20100434	2
9	SEAL CAP M8	16103699	8
10	SOCKET CAP SCREW M8X25 - DIN 912	20101978	8
11	NUT M8 DIN 934 - SP	20200119	8
12	TUBE CONNECTOR KIT	03700382	1
13	SELF DRILLING SCREW 6.3X25	00103077	4
14	CONN.TUBE F/ RESTR.TUBE FA 125	13701644	1

Return tandem FA 75 - 03104814

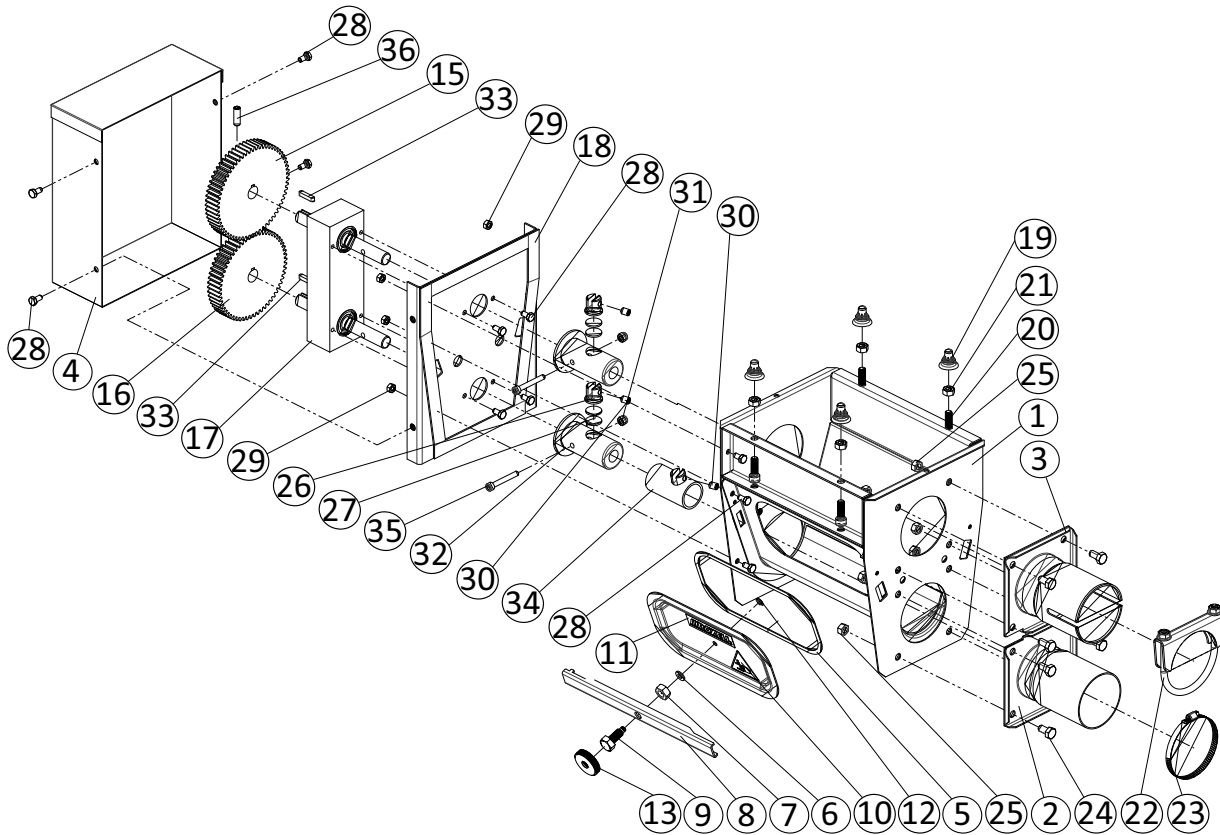

Key	Name	Part Nr.	Qt.
1	TANDEM BOOT BODY WELDMENT FA75	13108287	1
2	TUBE ANCHOR WELDMENT ASS'Y	13108337	1
3	TUBE ANCHOR WELDMENT ASS'Y	13108352	1
4	PROTECTION BOX ASS'Y	13108089	1
5	GASKET 15 x 2	30800874	1
6	FIBER RING	20104287	1
7	NUT M10-DIN 934	20100277	1
8	CLOSING PROFILE	13107768	1
9	CLOSING BOLT - BRASS SMAL	13108154	1
10	DECAL - HANDS WARNING	13106596	1
11	DECAL - ROXELL 73x18	10102697	1
12	E-RING DIA.5-DIN 6799-S.S	20102018	1
13	KNURLED KNOB	13107842	1
14	CLOSING PLATE	13107776	1
15	SPUR GEAR (POLYAMIDE)	10300432	1
16	SPUR GEAR (STEEL)	10300440	1
17	DRIVER ASSY TANDEM RETURN BOOT FA90	13204244	1
18	FLANGE ASS'Y WITH GASKET	13109894	1
19	RUBBER CAP M 8	16103699	4
20	SOCKET CAP SCREW M8 X 25 - DIN 912	20101978	4
21	NUT M8 DIN 934 - SP.	20200119	4
22	TUBE CLAMP ASSEMBLY	03900065	1
23	HOSE CLAMP Ø70-90	03100658	1
24	BOLT M8X16-DIN 933-8.8	20100228	8
25	NUT M8 - DIN 934	20200028	8
26	CLAMP PIN	13100482	2
27	BOLT M6 X 12 - DIN 933-8.8	20100160	16
28	NUT M6 - DIN 934	20100210	6
29	SET SCREW M8 x 10 - DIN 916	20100434	3
30	LOCKNUT M6 - DIN 985 -A2	20101960	2

Key	Name	Part Nr.	Qt.
31	DRIVER WELDMENT FA	13104237	2
32	SQUARE KEY	13102942	2
33	RESTRICTOR WELDMENT	13107636	1
34	SOCKET CAP SCREW M6x45 - A2	20108445	2
35	SET SCREW M8X25-DIN 916	20101580	2

Return tandem FA 90 - 03203022

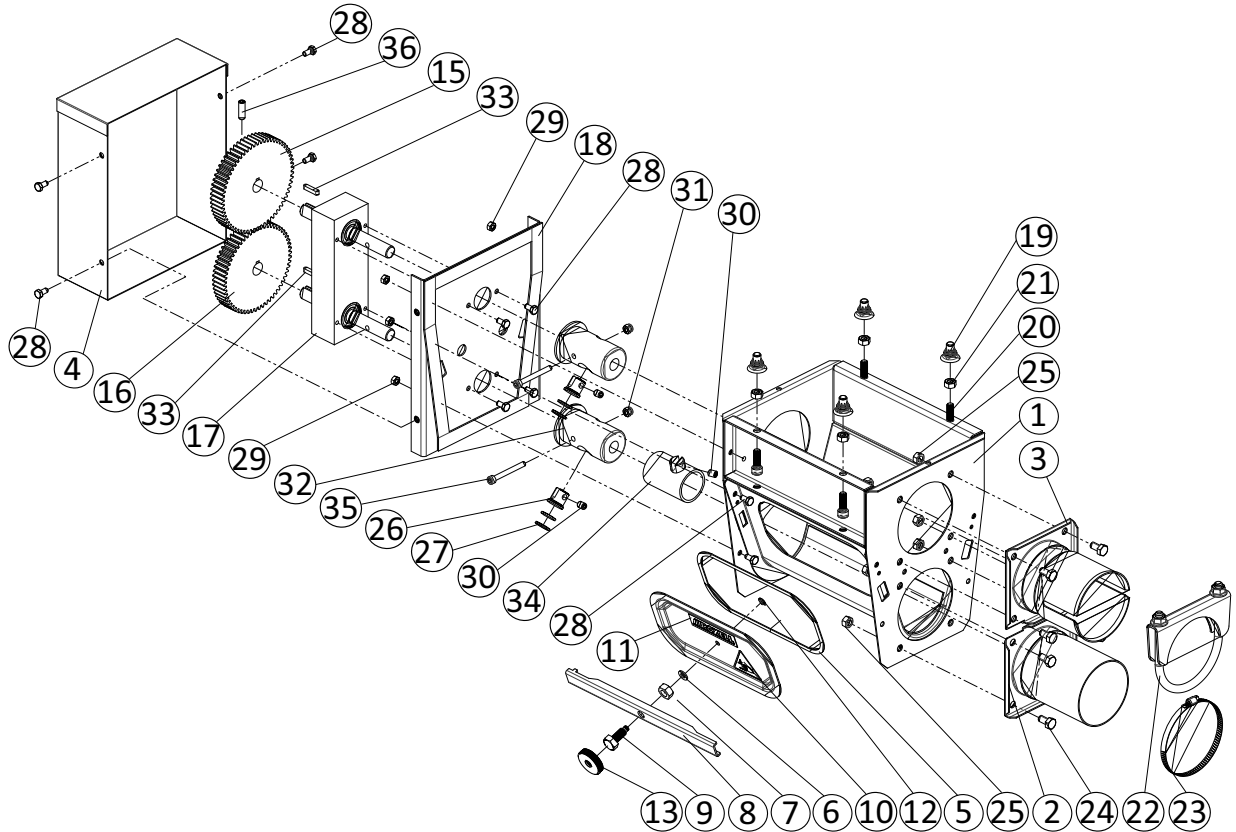

Key	Name	Part Nr.	Qt.
1	TANDEM BOOT BODY WELDMENT 90	13203096	1
2	TUBE ANCHOR WELDMENT	13203112	1
3	TUBE ANCHOR WELDMENT ASS'Y	13203104	1
4	PROTECTION BOX ASS'Y	13108089	1
5	GASKET 15 x 2	30800874	1
6	FIBER RING	20104287	1
7	NUT M10-DIN 934	20100277	1
8	CLOSING PROFILE	13107768	1
9	CLOSING BOLT - BRASS SMAL	13108154	1
10	DECAL - HANDS WARNING	13106596	1
11	DECAL - ROXELL 73x18	10102697	1
12	E-RING DIA.5-DIN 6799-S.S	20102018	1
13	KNURLED KNOB	13107842	1
14	CLOSING PLATE	13107776	1
15	SPUR GEAR (POLYAMIDE)	10300432	1
16	SPUR GEAR (STEEL)	10300440	1
17	DRIVER ASSY TANDEM RETURN BOOT FA90	13204244	1
18	FLANGE ASS'Y WITH GASKET	13204252	1
19	RUBBER CAP M 8	16103699	4
20	SOCKET CAP SCREW M8 X 25 - DIN 912	20101978	4
21	NUT M8 DIN 934 - SP.	20200119	4
22	TUBE CLAMP ASSEMBLY Ø95	3200029	1
23	HOSE CLAMP Ø80-100	3200250	1

Key	Name	Part Nr.	Qt.
24	BOLT M8X16-DIN 933-8.8	20100228	8
25	NUT M8 - DIN 934	20200028	8
26	CLAMP PIN	13100482	2
27	SPACER	13200134	4
28	BOLT M6 X 12 - DIN 933-8.8	20100160	14
29	NUT M6 - DIN 934	20100210	6
30	SET SCREW M8 x 10 - DIN 916	20100434	3
31	LOCKNUT M6 - DIN 985 -A2	20101960	2
32	DRIVER WELDMENT	10300473	2
33	SQUARE KEY	13102942	2
34	RESTRICTOR WELDMENT	13202809	1
35	SOCKET CAP SCREW M6x55 - A2	20108437	2
36	SET SCREW M8X25-DIN 916	20101580	2

Return box closing plate kit - 03001269

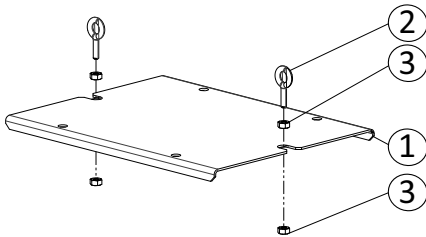

Key	Name	Part Nr.	Qt.
1	RETURN BOX CLOSING PLATE	13108410	1
2	EYEBOLT M6X20	20100772	2
3	NUT M6 - DIN 934	20100210	4

Tandem return boot FA 125 - 03702037

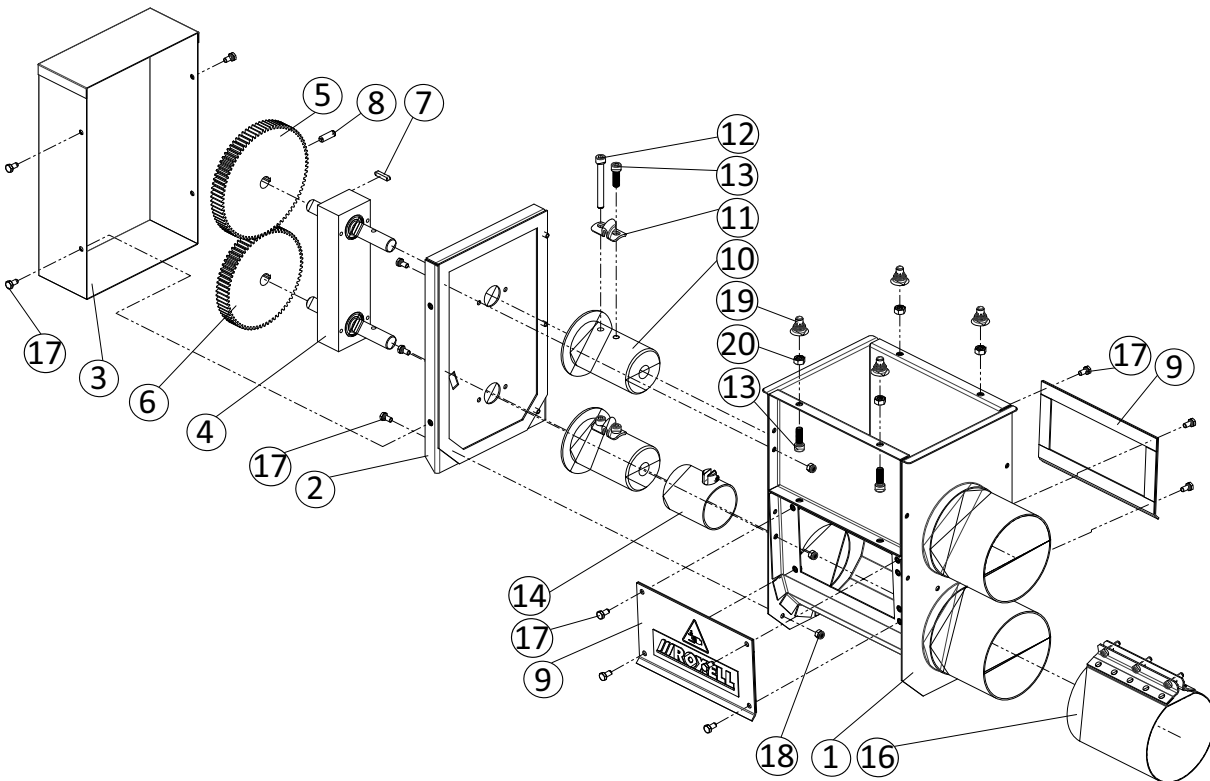

Key	Name	Part Nr.	Qt.
1	TANDEM BOOT BODY WELDMENT	13701032	1
2	FLANGE ASS'Y WITH GASKET	13704060	1
3	PROTECTION BOX	13106471	1
4	DRIVER ASSY RET.Boot FA125	13704084	1
5	SPUR GEAR (POLYAMIDE)	13202122	1
6	SPUR GEAR STEEL - Z=70	13704156	1
7	SQUARE KEY	13102942	2
8	SET SCREW M8X25-DIN 916	20101580	2
9	CLOSING PLATE ASS'Y	13102629	2
10	ANCHOR WELDMENT FA 125	13700984	2
11	ANCHOR CLAMP	13104575	2
12	SOCKET CAP SCREW M8 X 70 - DIN 912	20101986	2
13	SOCKET CAP SCREW M8 X 25 - DIN 912	20101978	6
14	RESTRICTOR WELDMENT	13701263	1
15	SET SCREW M8 x 10 - DIN 916	20100434	1
16	TUBE CONNECTOR KIT	03700382	1
17	BOLT M6 X 12 - DIN 933-8.8	20100160	22
18	NUT M6 - DIN 934	20100210	6
19	RUBBER CAP M 8	16103699	4
20	NUT M8 DIN 934 - SP.	20200119	4

Thumper for return tandem - 03102951

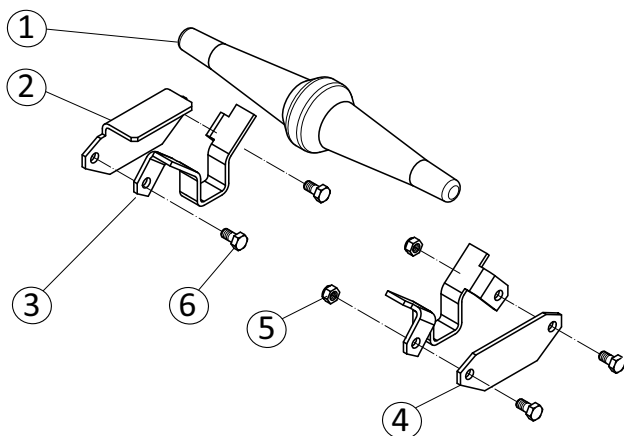

Key	Name	Part Nr.	Qt.
1	THUMPER RETURN	13108220	1
2	THUMPER RETURN STOP - LEFT	13108253	1
3	THUMPER RETURN HOLDER	13108238	2
4	THUMPER RETURN STOP - LEFT	13108246	1
	HARDWARE KIT	13108261	
5	LOCKNUT M6 - DIN 985	20100400	2
6	BOLT M6 X 16 - DIN 933 - 8.8	20100178	4

Pellet guides for return tandem – 03202470

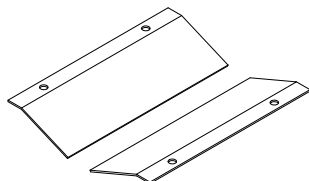

Key	Name	Part Nr.	Qt.
1	PELLET GUIDE FA 90 - RIGHT HAND	13200670	2

Flex-Auger Mix system

General view Flex-Auger Mix

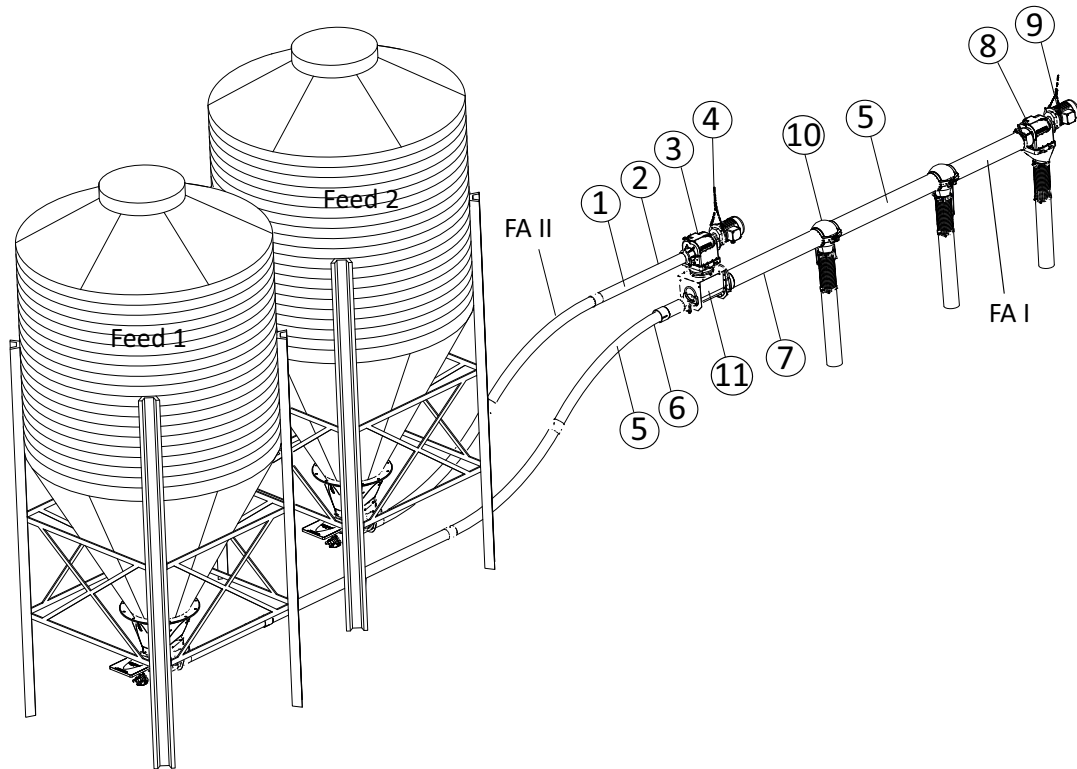

Component numbers

Key	Name	Number
1	AUGER - FA 75	03100187
2	NOVICOR TUBE - 3 M Ø 75 MM	03100559
3	CONTROL UNIT FA75	03103256
4	POWER UNIT	MISCELLANEOUS
5	AUGER FA 90	03200409
6	NOVICOR TUBE LG = 3 M Ø 89 MM	03200300
7	NOVICOR TUBE LG = 3 M Ø 127 MM	03700069
8	CONTROL UNIT FA-MIX	03000197
9	POWER UNIT	MISCELLANEOUS
10	OUTLET DROP ASSEMBLY W/SHUT OFF (MOD 125)	03700093
11	BOOT ASSEMBLY FA MIX	03000536

Boot assembly Flex-Auger mix - 03000536

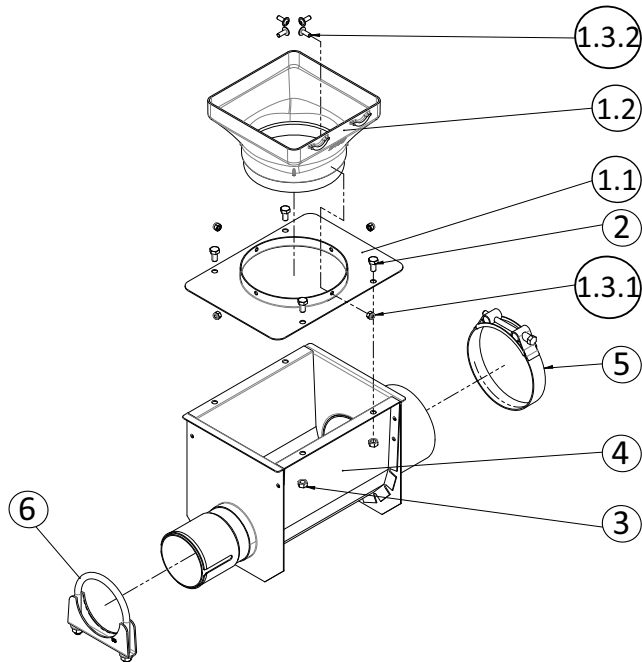

Key	Name	Part Nr.	Qt.
1	FA EXTENSION 360°/INTAKE BOOT	03000544	1
1.1	EXTENSION PLATE Ø160 GALVA	13109525	1
1.2	DROP ø160 FOR EXTENSION BOOT	13000492	1
1.3	HW KIT F/ FA EXTENSION 360°	13000518	1
1.3.1	LOCKNUT M6 - DIN 985 -A2	20101960	4
1.3.2	BUT.HEAD CAP SCREW W/FLANGE M6x16-A2	20109146	4
2	BOLT M8X16-DIN 933-8.8	20100228	4
3	NUT M8 - DIN 934	20200028	4
4	BOOT BODY WELDMENT - FA MIX	13701529	1
5	HOSE CLAMP ø131-139MM	03701196	1
6	TUBE CLAMP ASSEMBLY Ø95	03200029	1

Power unit Flex-Auger Mix

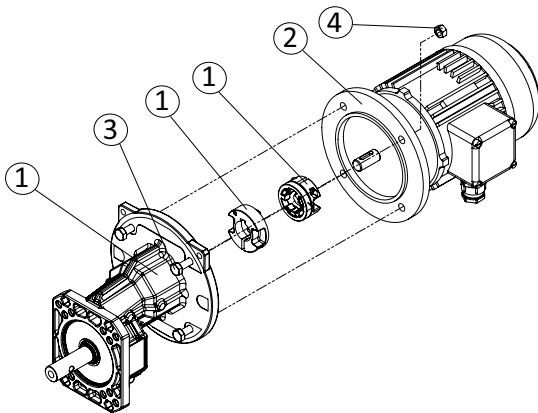

Name	Part Nr .
SERVICE PARTS	On Demand
FAN COVER	On Demand
CONNECTION BOX	On Demand
CAPACITOR 1-PHASE MOTOR	On Demand
CABLE RING	On Demand

Key	Name	Part Nr.	Qt.
	POWER UNIT	0..(See table)	1
1	GEARBOX	1..(See table)	1
2	MOTOR	1..(See table)	1
3	BOLT M8X30-DIN 933-8.8	20100244	4
4	NUT M8 - DIN 934	20200028	4



ATTENTION: The motor is standard in triangle! Do not change this!

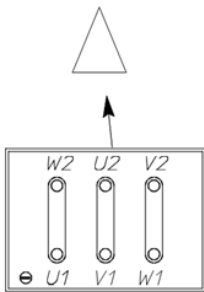

System	FA-Mix
Gearbox With Key	13105176
Gearbox With F-Coupling alu	13109820
Type Elastic Coupling Set (CS 71-80-90)	CS71 13204180
Motor Shaft	Ø14
Ratio	7.875
Output speed 50 Hz	175
Output speed 60 Hz	210
Construction size	71
Motor speed 50 Hz (RPM)	1,500
Motor speed 60 Hz (RPM)	1,800
Feed capacity kg	600
Max. Run Time	2 h/day
3x230/400 V 50 Hz IE1	03001187
Motor IE1	13106687 (0.74 kW)

Control unit Flex-Auger mix FA 125 – 03001211

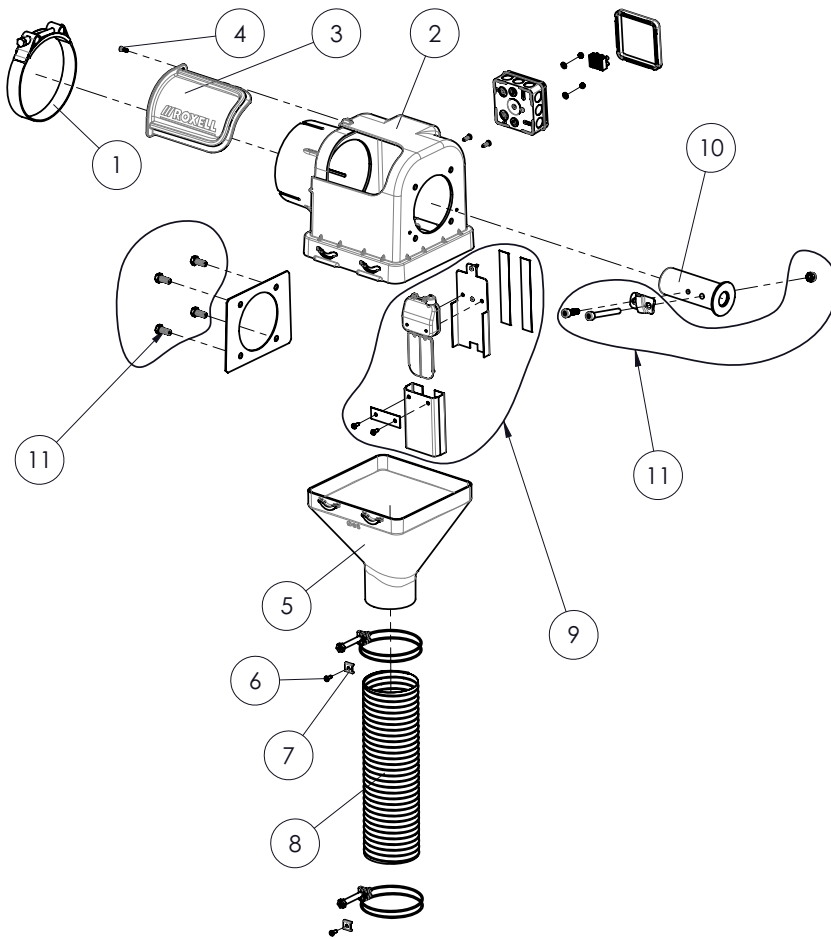

Key	Name	Part Nr.
1	HOSE CLAMP ϕ 131-139MM	03701196
2	HOUSING - CONTROL UNIT DIA125	13702996
3	WINDOW	13000500
4	THREAD FORMING SCREW 4X12-A2	12502043
5	DROP FOR DROP TUBE DIA 85	13203815
6	PARCKER SCREW 8 X 1/2"	20100525
7	BOW CLAMP	13103643
8	FLEXIBLE TUBE ASS'Y ϕ 85 MM	03100633
9	SAFETY SWITCH ASS'Y	13000757
10	DRIVER WELDMENT	13201561
11	HARDWARE KIT CU FA 90	13203849

Tube anchor weldment - 13701412

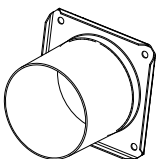

Control panel Flex-Auger Mix

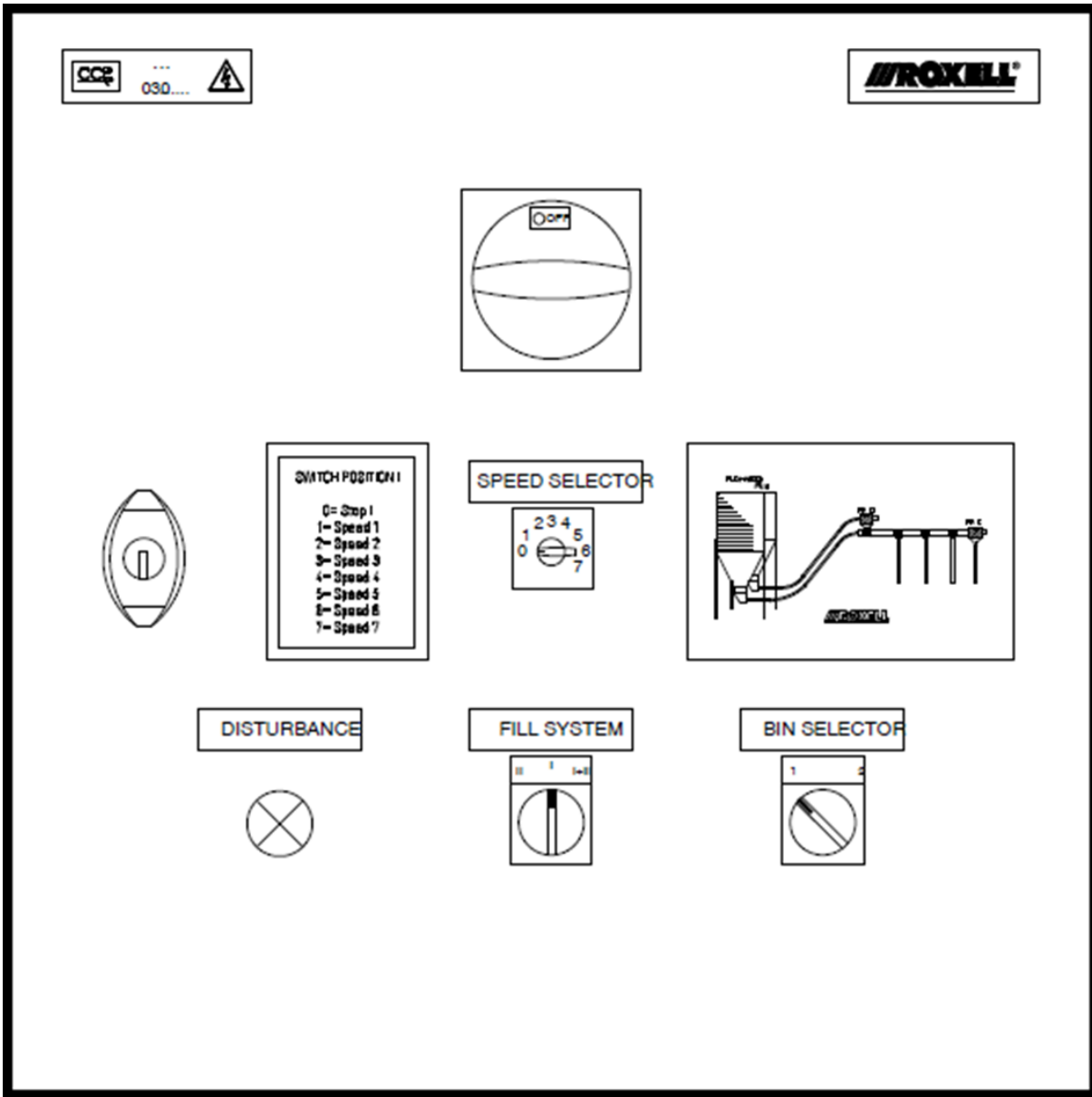

3X400 V - 50 Hz	03000510
3X230 V - 50 Hz	03000528
1X230 V - 50 - 60 Hz	03000502
3X200 V - 50 - 60 Hz	03000338

III Installation instructions

General safety rules

Flex Auger Nr.: 031...

Transport system of dry feed for animals



DANGER: Carefully read the instructions before you install the system.

- Pay attention when you work with the auger coil:
 - It is possible that the auger unrolls when you release the binding wire. This can cause injuries.
 - Always use safety gloves, when you slide the auger into the tube.
 - Always use clamps to avoid that the auger springs back, when you put it under tension or couple it.
- Check all the elbow and tube connections, and all the tube clamps on the control unit, boot and bearings for proper clamping.
- Tighten all the tube clamps with a torque of min. 10 Nm.
- Ensure to provide solid suspension points. Each suspension point should be able to hold min. 50 kg.
- If the auger hitches or blocks at the first start-up, ensure that you can immediately turn off the system with the main switch on the control panel.

	Carefully read the User's Guide and Use & Assembly Guide.
	Unauthorized persons are forbidden.
	<p>This symbol will be used to draw your attention to matters that are of great importance for your safety. It means: Warning.</p> <ol style="list-style-type: none"> 1. Follow the safety instructions. 2. Disconnect the current. 3. Reread the safety instructions. <p>In short: be alert. It can cause serious injuries or even death.</p>

Tools

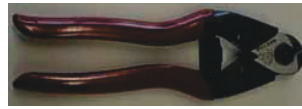
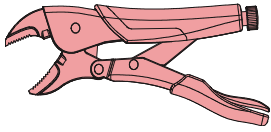

09700097

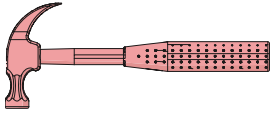

metal: Ø3–13
concrete: Ø9, Ø7 and Ø2.8

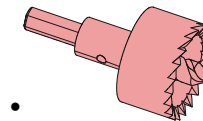
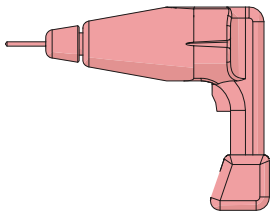
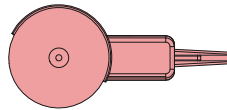
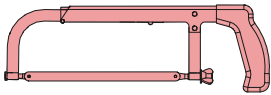

-
- Ø32 – 09701699 (Sensor)
- Ø40 – 09700022 (Mod. 55)
- Ø51 – 09700030 (Mod. 75)
- Ø70 – 09700048 (Mod. 90)
- Ø108 – 09700055 (Mod.125)
- Ø130 – holes in wall

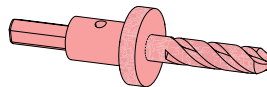
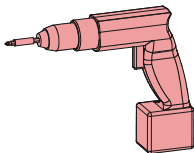

09700071

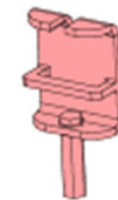
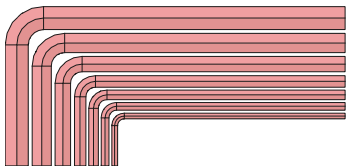

Ø6 – 09700220

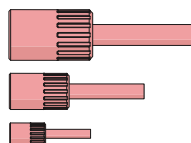
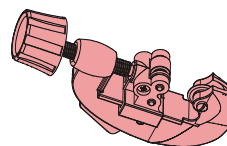
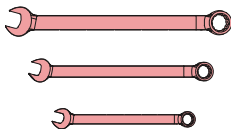

Directions for designing the system

- Install the feed bin in line with the feed troughs, if possible.



ATTENTION: Avoid left-hand elbows: The feed does not protect these elbows against wear.

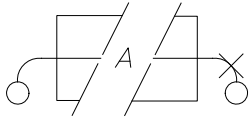

- Provide adequate electrical wiring to power the motors.
- Use as much as possible three-phase motors:
 - Less interference
 - Operationally reliable
 - More economical
- Do not mount outlets on or just before an elbow. Always mount the outlet behind the elbow.

IMPORTANT: If not possible, ensure that some of the feed can pass through. This will make your system run smoother.

- If you want to install an extension boot: See [Graphs with maximum lengths](#).
 - You can avoid an extra elbow: Install the extension boot under 90° on the transport system. For certain applications you can turn the extension boot 180°.
 - Use an extension boot if the Flex-Auger 125 with tandem is longer than 10 m: See [Model 125 – 33 m: For Novicor or steel elbow and tube](#). This prevents the last part of the system from running empty for a long time.
 - Install the extension boot in such a way that no outlets can occur until past the next elbow.
 - Install the extension boot just before the middle of the total line length. The longest part of the line (the one with the most outlets) must be located past the extension boot.
 - Always install the extension boot before the elbow, if any. This prevents wear and tear.
- If you want to install a tandem system:



NOTE: The tandem system is the straight-line connection between two feed bins. This allows you to provide the house with two different types of feed or to double your storage capacity, using only one Flex-Auger.

- Ensure that the auger of the tandem and the auger of the transport system run in the same axis line.
- Never install an elbow between 2 feed bins.
- Install the feed bins at a minimum distance.
- Pour one flat concrete slab for both bins. Consult the feed bin manufacturer for dimensions.
- Install the Flex-Auger at least 1.5 m horizontally past the second boot, to avoid wear of the second boot.

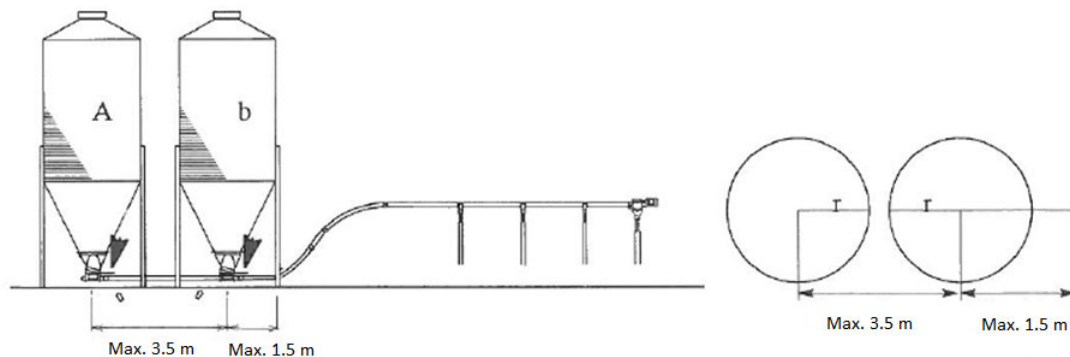









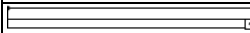
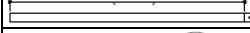

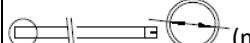
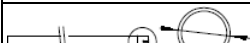
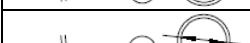
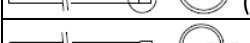
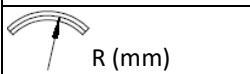
Elbow and tube specifications

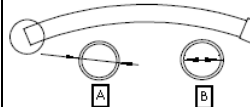

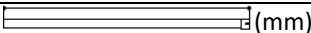

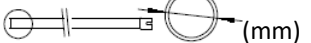

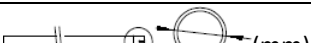
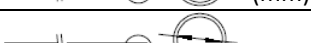
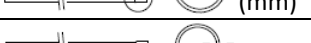
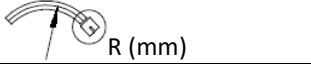
ATTENTION: See also the Technical Data Sheet in part I and Graphs with maximum lengths.

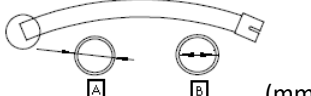
Novicor

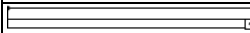
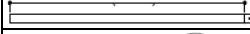

Flex-Auger	55	75 LC	75 HC	90 LC	90 HC	90 HD
Tube nr.	03300084	03100559	03100559	03200300	03200300	03200300
 (mm)	3050	3075	3075	3090	3090	3090
 (mm)	3000	3000	3000	3000	3000	3000
 (mm)	56	75	75	89	89	89
 (mm)	51	68.6	68.6	82.2	82.2	82.2
 (mm)	61.3	81.7	81.7	96.1	96.1	96.1
 (mm)	56.3	75.3	75.3	89.3	89.3	89.3
 (mm)	2.5	3.2	3.2	3.4	3.4	3.4
Elbow nr.	03300977	03100542	03100542	03200326	03200326	03200326
 R (mm)	1533	1533	1533	1568,5	1568,5	–
 (mm)	1593	1308	1308	1357	1357	–
 (mm)	• A = 56 • B = 51	• A = 75 • B = 68.6	• A = 75 • B = 68.6	• A = 89 • B = 82.2	• A = 89 • B = 82.2	–

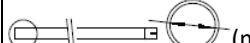
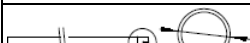
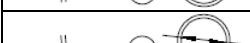
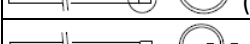
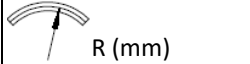
Flex-Auger	125 LC	125 HC
Tube nr.	03700069	03700069
 (mm)	3105	3105
 (mm)	3000	3000
 (mm)	127	127
 (mm)	117	117
 (mm)	137	137
 (mm)	127	127
 (mm)	5	5
Elbow nr.	03700051	03700051
 R (mm)	1700	-
 (mm)	1485	-
 (mm)	5	-
 (mm)	<ul style="list-style-type: none"> • A = 127 • B = 117 	-

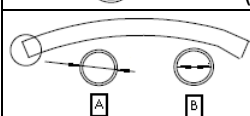
Steel

Flex-Auger	90 LC	90 HC	90 HD	125 LC	125 HC
Tube nr.	03200102	03200102	03200102	03700200	03700200
 (mm)	3090	3090	3090	3105	3105
 (mm)	3000	3000	3000	3000	3000
 (mm)	89	89	89	127	127
 (mm)	82.2	82.2	82.2	123	123
 (mm)	96.1	96.1	96.1	–	–
 (mm)	89.3	89.3	89.3	–	–
 (mm)	1.5	1.5	1.5	2	2
Elbow nr.	03200433	03200433	03200433	03700002	03700002
 R (mm)	1568.5	1568.5	–	–	–
 (mm)	1357	1357	–	1179	1732
 (mm)	–	–	–	3	3
 (mm)	• A = 96.1 • B = 89.3	• A = 96.1 • B = 89.3	–	• A = 126 • B = 120	• A = 126 • B = 120

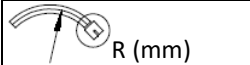
Densicor

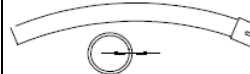
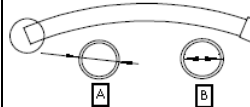
Flex-Auger	125 LC	125 HC
Elbow nr.	03701116	03701116
 R (mm)	–	2200
 (mm)	–	1979
 (mm)	–	5
 (mm)	• A = 127 • B = 117	• A = 127 • B = 117

Elbow diagrams

Example: See [Elbow diagram Flex-Auger model 55-75-90](#).

- If you want to enter the house under 30° at a height of 2.2 m:
 1. Draw an auxiliary line A from height 2.2 m to the point of intersection with the 30° axis.
 2. Drop the vertical B from the point of intersection. The bin centre must be located at 4.4 m from the house wall.
- If you want the bin centre at a certain distance from the wall and with a certain angle of inclination: Follow the opposite procedure with adapted distances.

Elbow diagram Flex-Auger model 55-75-90

Boot straight-out

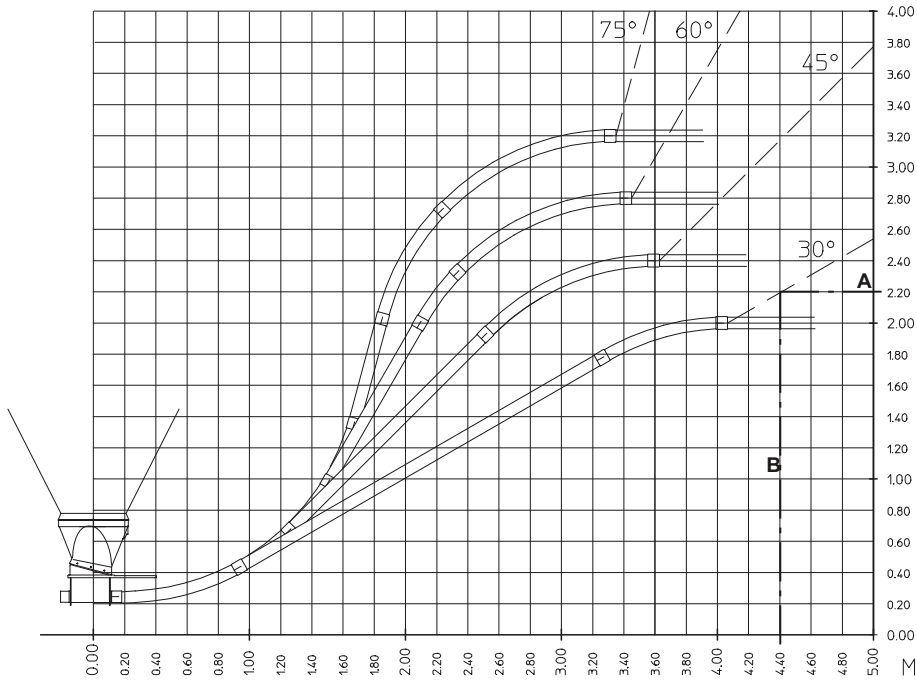

Boot at 30°

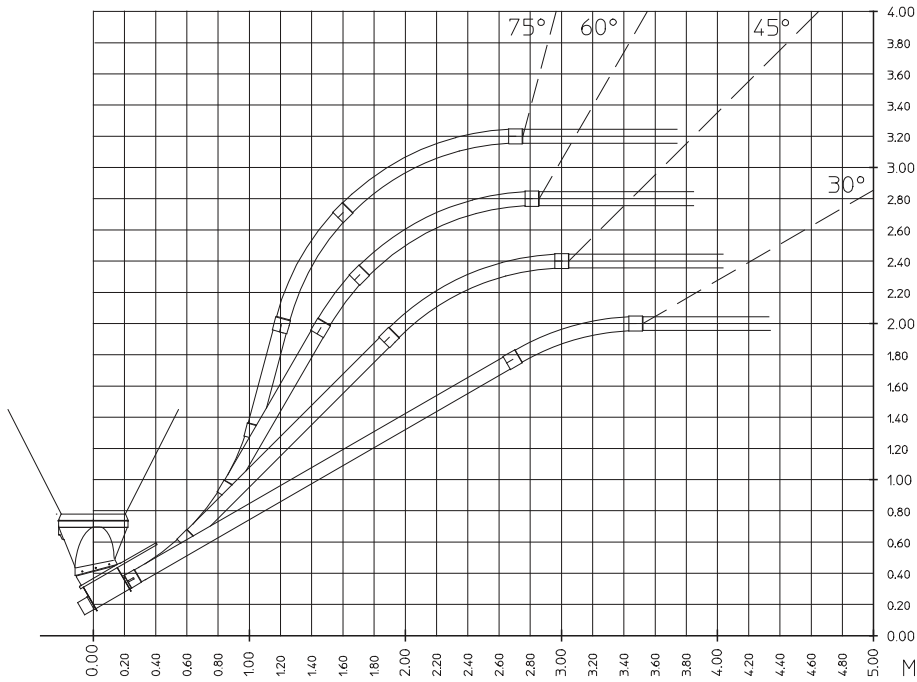

Elbow diagram Flex-Auger model 125 – R = 1700

Boot straight-out

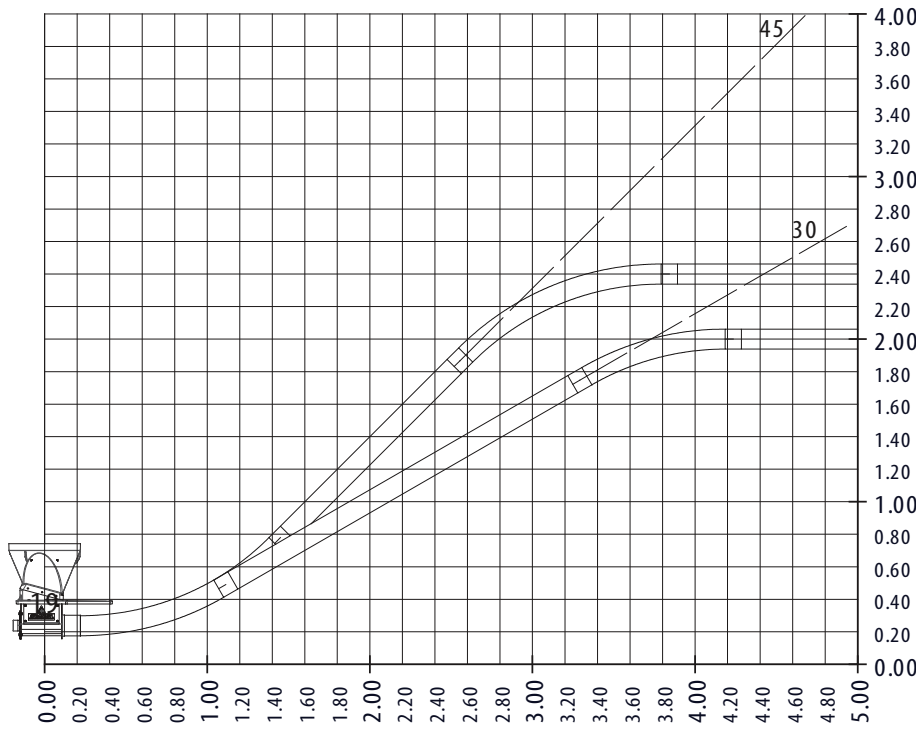

Boot at 30°

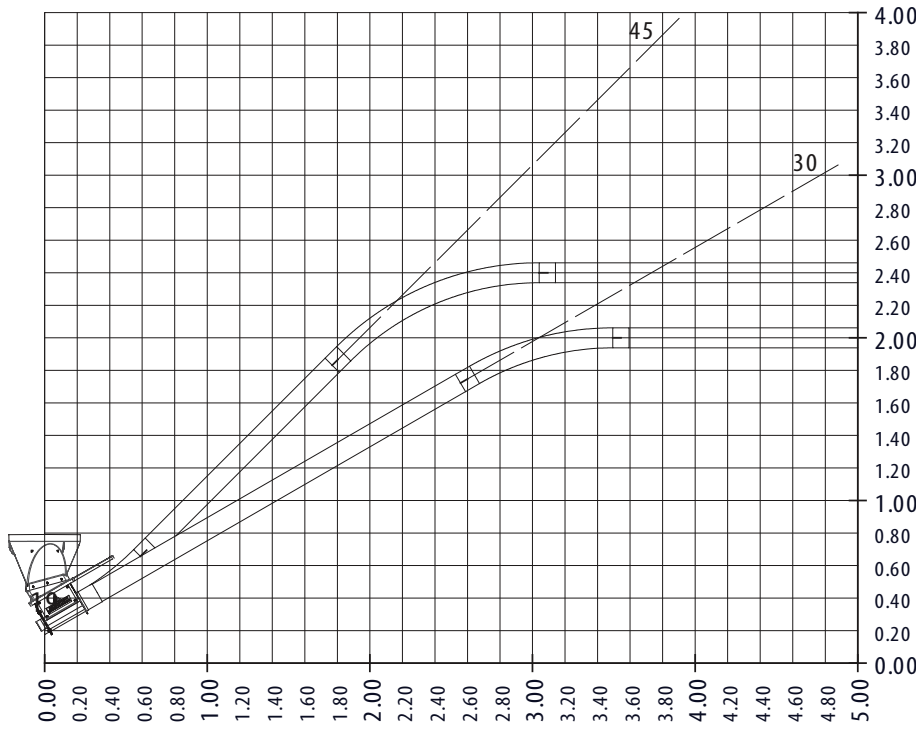

Elbow diagram Flex-Auger model 125 – R = 2200

Boot straight-out

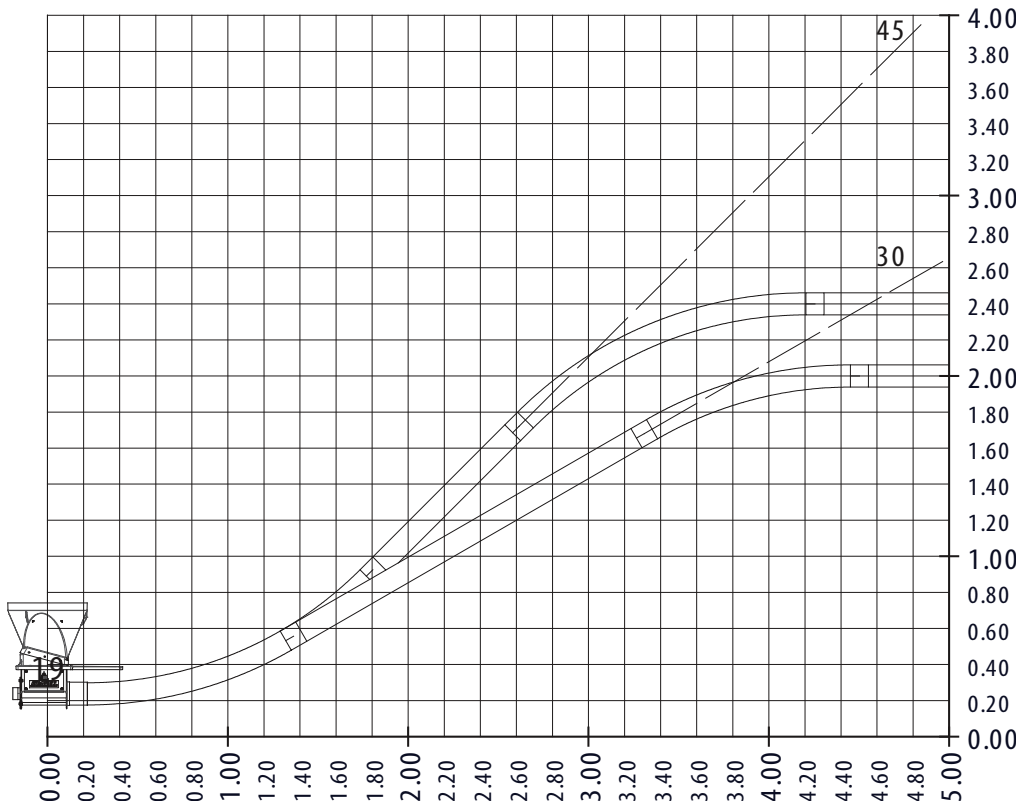

Boot at 30°

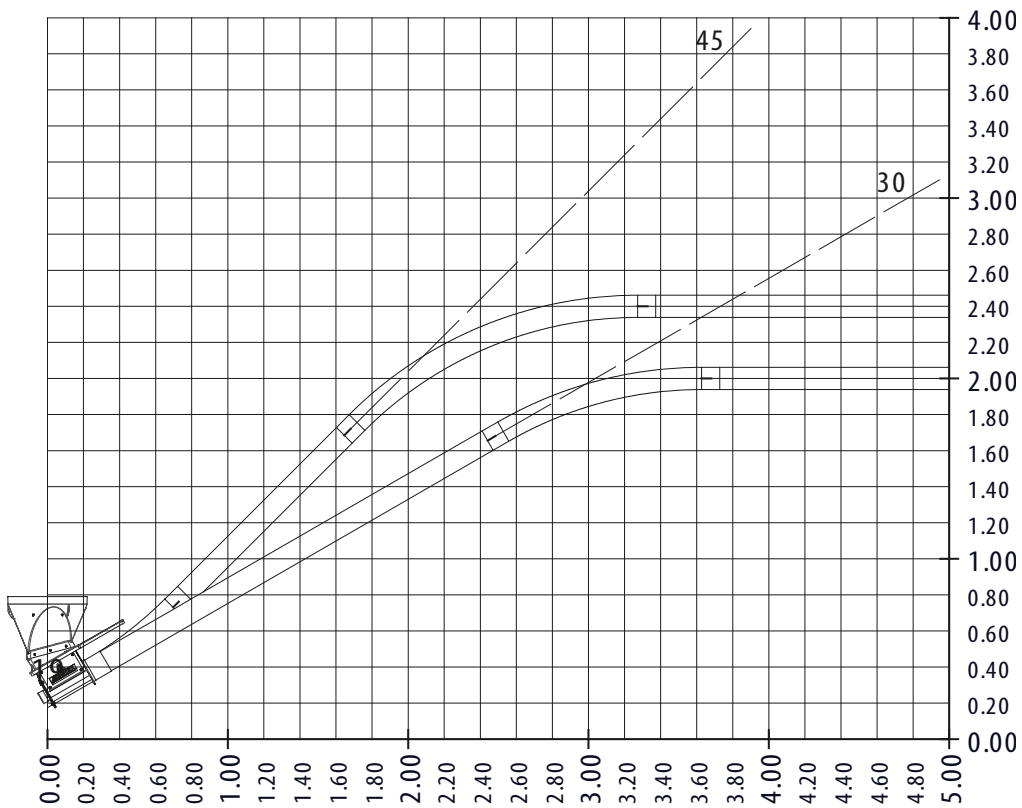

Graphs with maximum lengths

Model 55

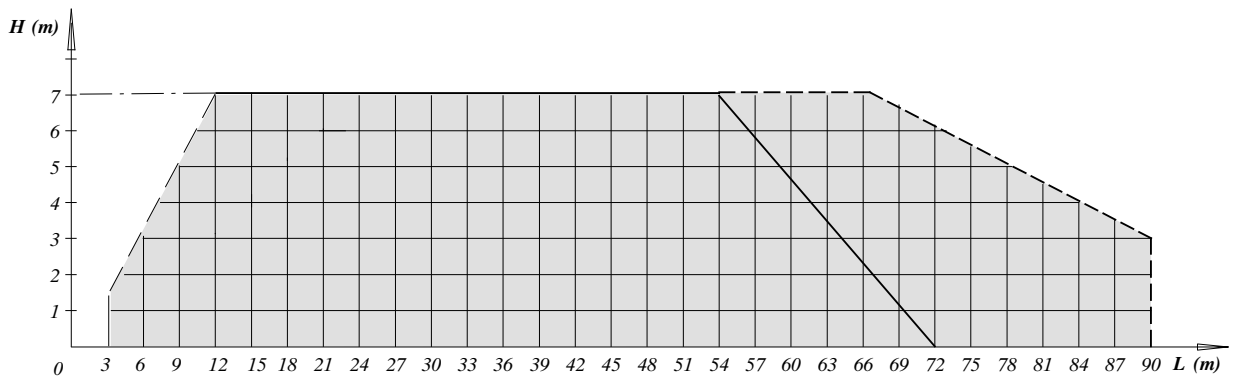
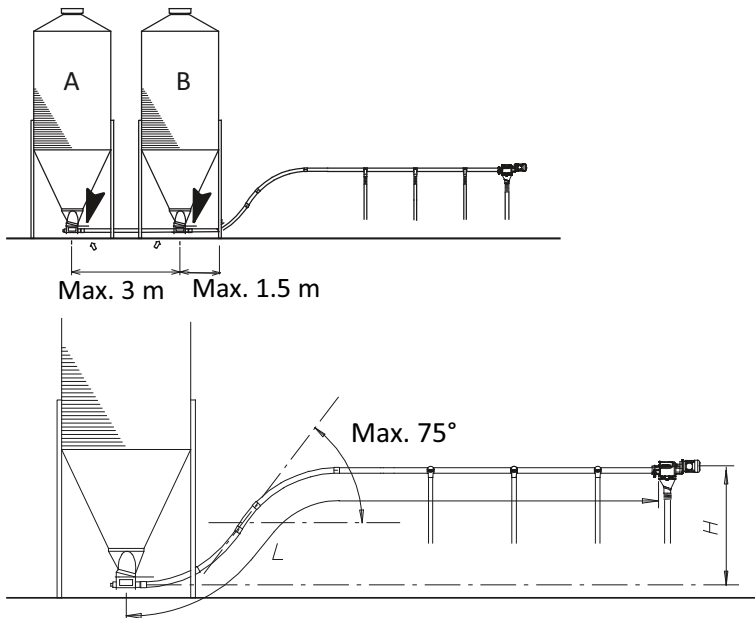

NOTE: - - - - -: With fill points every 0.5 m.



NOTE: The first extra elbow of 45° reduces the maximum length with 3 m. The following extra elbows with 4.5 m.



NOTE: All lengths within the graph are allowed. If the dimensions exceed the graph limits, use an extension boot, and consider the system as two separate Flex-Augers.

Model 75

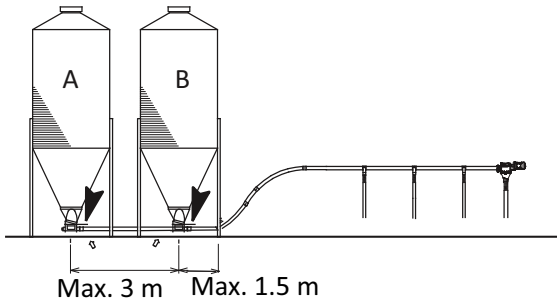
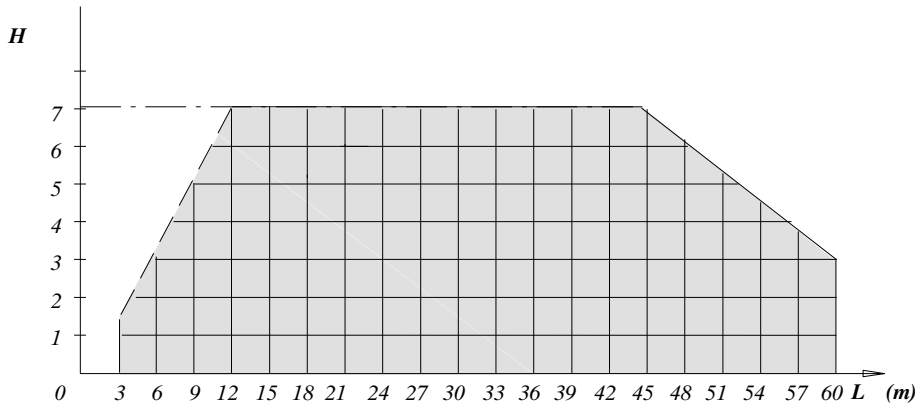
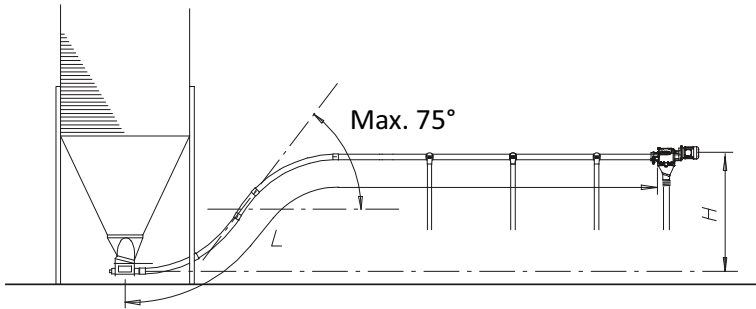
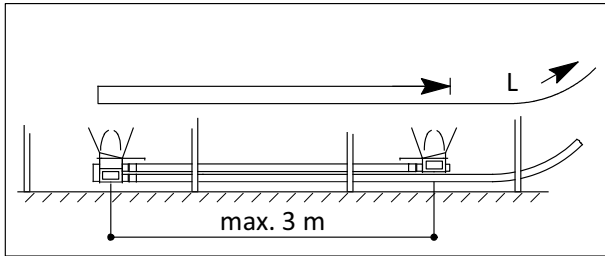

Fig. 1: For return tandem



NOTE: The first extra elbow of 45° reduces the maximum length with 3 m. The following extra elbows with 4.5 m.

NOTE: All lengths within the graph are allowed. If the dimensions exceed the graph limits, use an extension boot, and consider the system as two separate Flex-Augers.

Model 90

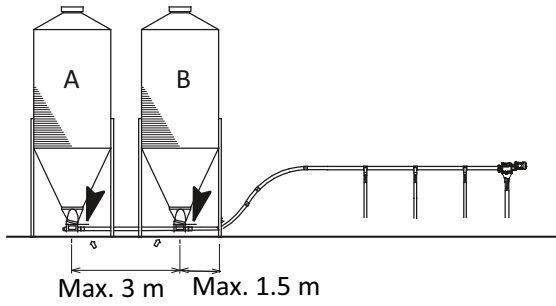
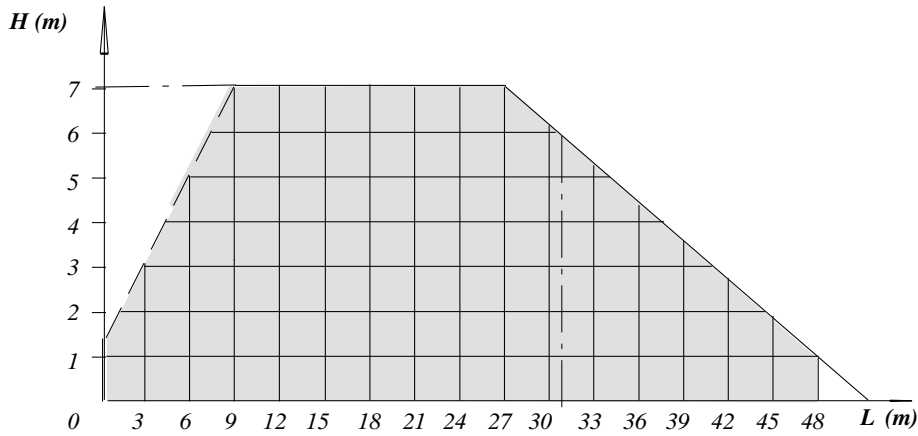
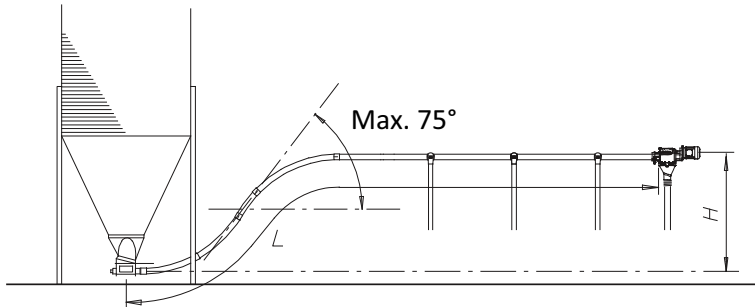
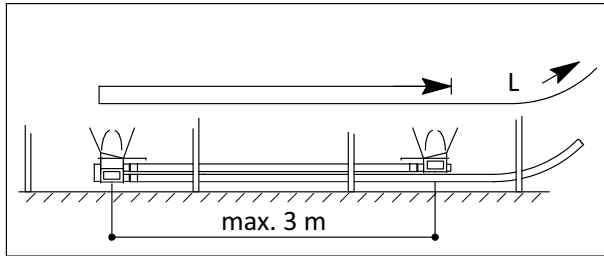

Fig. 2: For return tandem



NOTE: The first extra elbow of 45° reduces the maximum length with 3 m. The following extra elbows with 4.5 m.



NOTE: All lengths within the graph are allowed. If the dimensions exceed the graph limits, use an extension boot, and consider the system as two separate Flex-Augers.

Model 125 – 33 m: For Novicor or steel elbow and tube

i NOTE: The graph is for one bin only.

For lines (with tandem) longer than 10 m: Use an extra power unit. This graph is correct for the second part of the Flex-Auger.

Fig. 3: For tandem

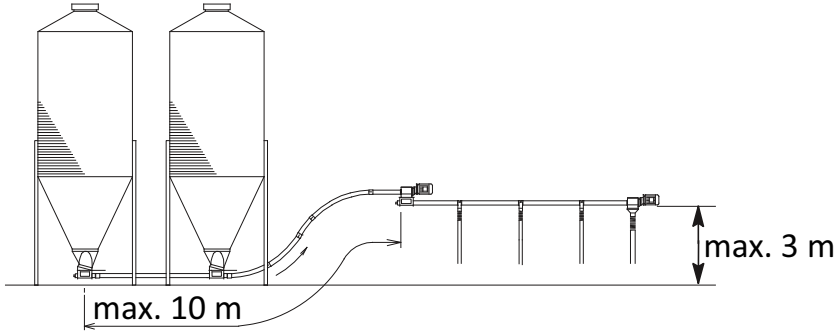
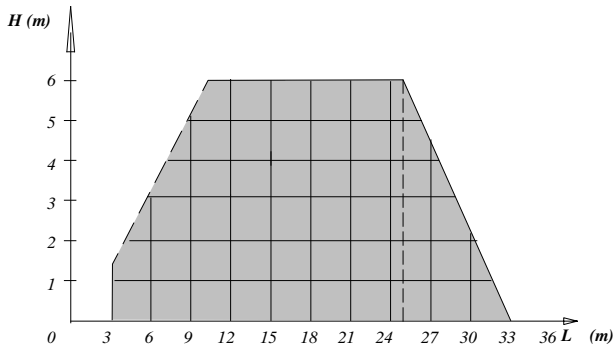
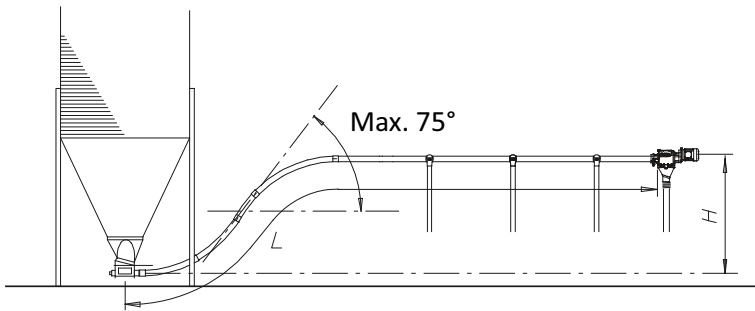
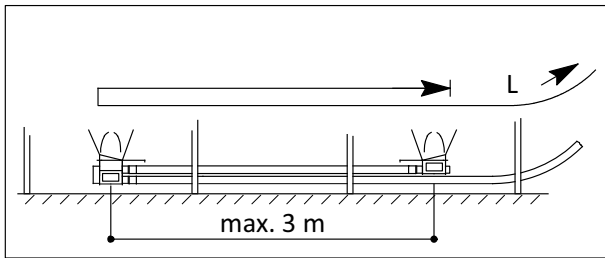

Fig. 4: For return tandem



i NOTE: The first extra elbow of 45° reduces the maximum length with 3 m. The following extra elbows with 4.5 m.

i NOTE: All lengths within the graph are allowed. If the dimensions exceed the graph limits, use an extension boot, and consider the system as two separate Flex-Augers.

Model 125 – 19 m: For Novicor tube with Densicor elbow

i NOTE: The graph is for one bin only.

For lines (with tandem) longer than 10 m: Use an extra power unit. This graph is correct for the second part of the Flex-Auger.

Fig. 5: For tandem

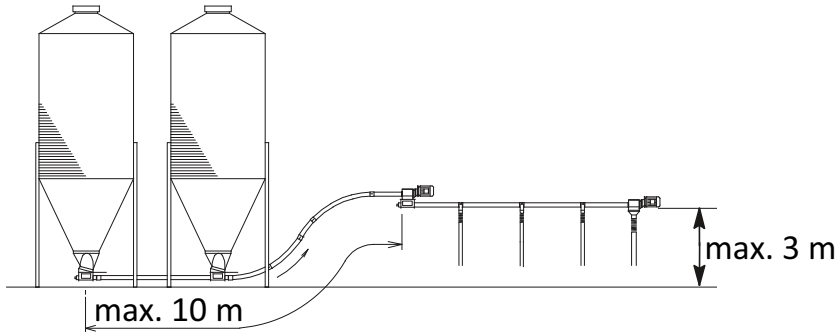
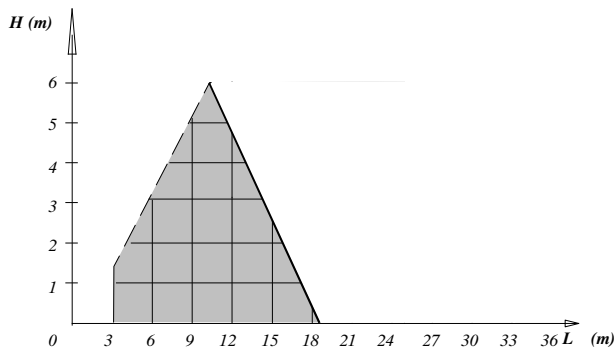
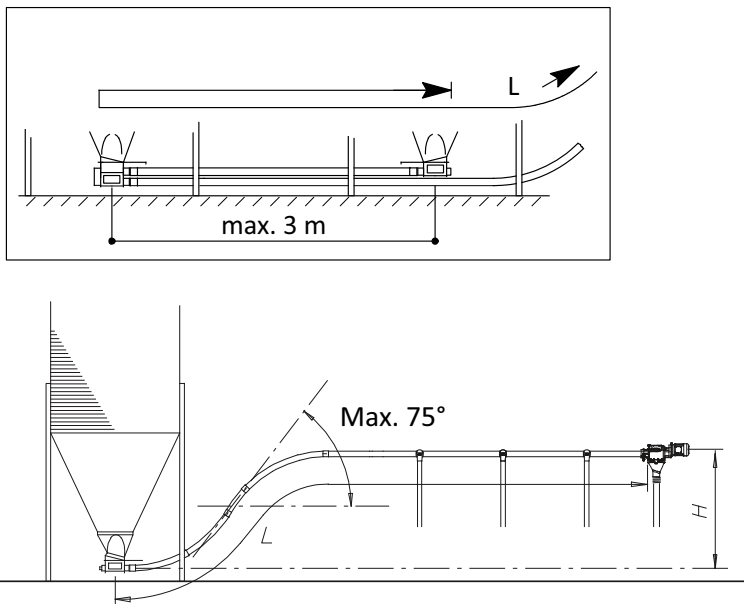

Fig. 6: For return tandem



i NOTE: The first extra elbow of 45° reduces the maximum length with 3 m. The following extra elbows with 4.5 m.

i NOTE: All lengths within the graph are allowed. If the dimensions exceed the graph limits, use an extension boot, and consider the system as two separate Flex-Augers.

Model 90/125: CDS – broiler cage

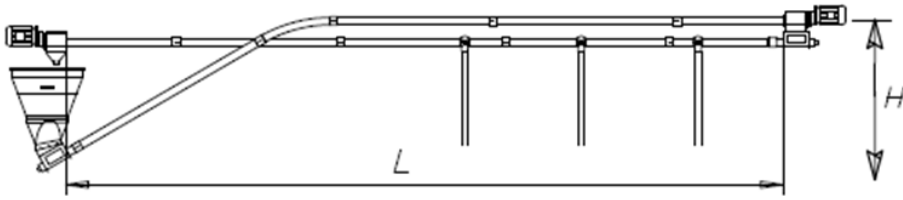

Model 90	Model 125

Model 90: Heavy Duty auger (HD)

i NOTE: Used for long distances.

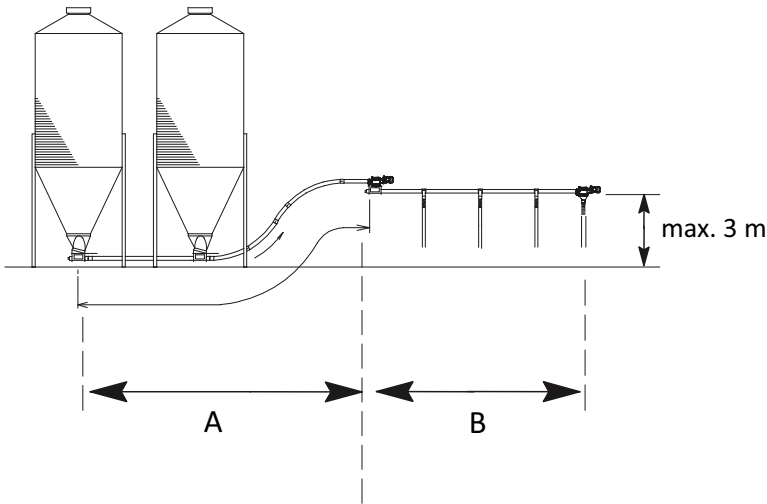

Reference	Description
A	Standard auger
B	Horizontal part = Heavy Duty auger (HD) 1.5 kW 450 rpm

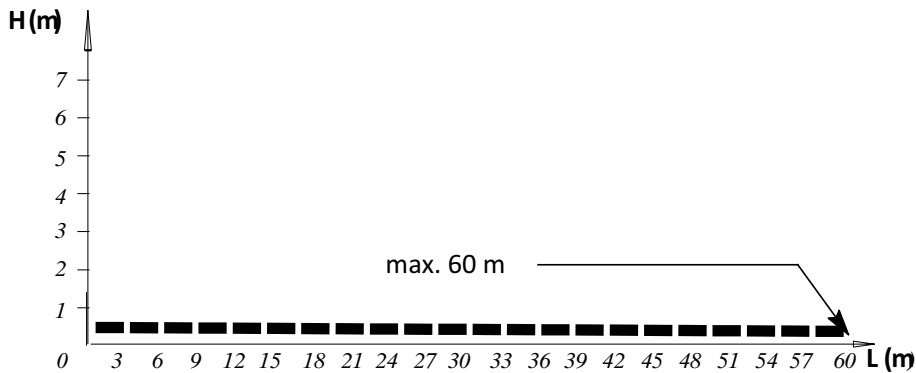

Bin location

See [Graphs with maximum lengths](#) to determine the most suitable location for your bin. Important are:

- Height of the horizontal tubes
- Position of the first outlet

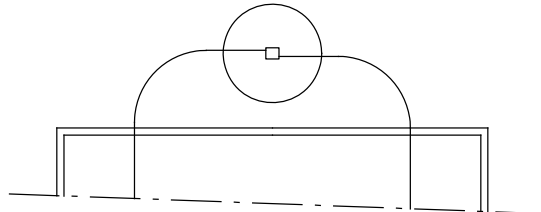
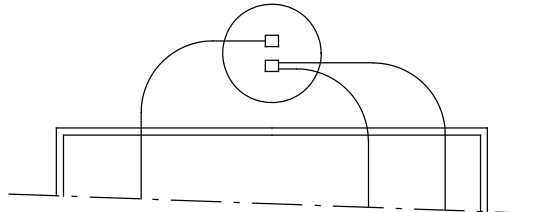

NOTE: When you install the boot under an angle of 30°, the capacity of the Flex-Auger is reduced with a percentage up to 30% according to the feed used.

<p>You can use a double intake boot (only for models 55, 75 and 90), to start with a transport system at either side.</p>	<p>If possible, install the bin in line with the Flex-Auger. Roxell provides 2 elbows of 45° for a standard system.</p>
	

Transport line location

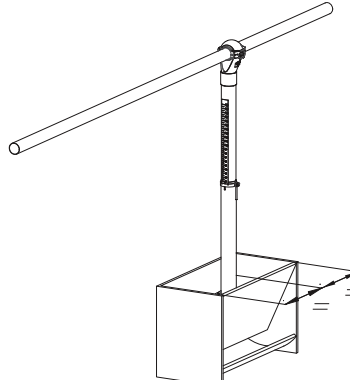
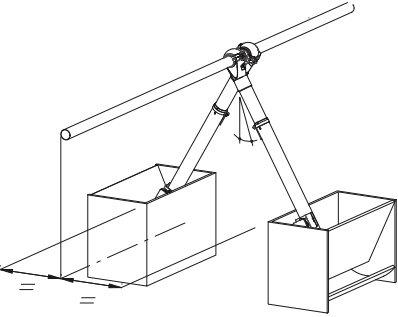
Single row of feed troughs	Double row of feed troughs
	
<p>Install the drop tube:</p> <ul style="list-style-type: none"> • In a feed trough: against the back wall • In a 100 kg hopper: in the centre 	<p>Suspend the line in the centre:</p> <ul style="list-style-type: none"> • Meal: max. 30° • Pellets: max. 45°

Suspension

To install the suspension points

- Ensure that the suspensions are firmly fixed.
- Install the suspension points in a straight line.

 **DANGER:** Each suspension point should be able to bear a 50 kg load (100 kg at the power unit).

Distance between the suspension points

- **Recommendation:** Suspend all the Flex-Auger components.
- Suspend in auger direction (no fixation of the tube support).
- Close the S-hook to increase the resistance.



NOTE: Maximum tensile force of the S-hook: 60 kg

• Distances

Model 55, 75, 90 and 125 (Novicor)	Model 90 and 125 (metal)
If distance between outlets <2 m: One suspension per outlet	One suspension every 3 m
If distance between outlets >2 m: Extra suspension in between	
If no outlets: One suspension every 2 m	

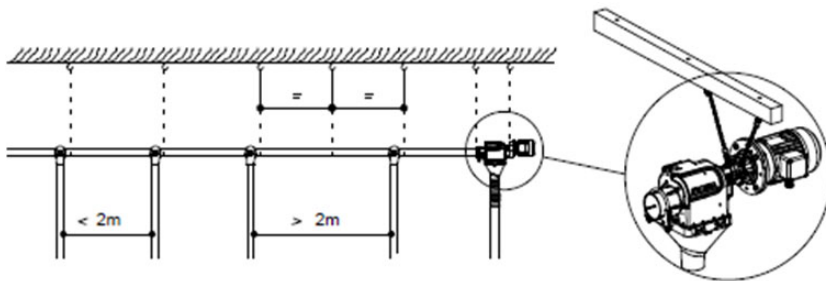

• Maximum load (kg) (incl. safety factor 3)

Tube material	Flex-Auger	Flex-Auger length			Extension boot	Power unit
		1 m	2 m	3 m		
Novicor	FA 55	6	13		53	59
	FA 75	14	28		68	74
	FA 90	16	33		87	93
	FA 125	29	59		98	94
Metal	FA 90			67	87	93
	FA 125			118	98	94

Suspension components

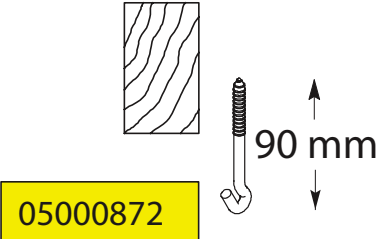
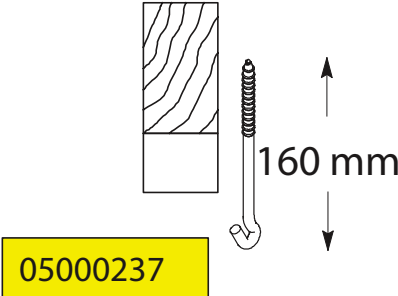
In wood	
Wooden beam	Wooden beam and insulation
 <p>05000872</p> <p>90 mm</p>	 <p>05000237</p> <p>160 mm</p>
<ul style="list-style-type: none"> • Drill a small hole in hard wood, to avoid that screw hooks break off. • Use a drilling machine with our special driver for screw hooks. 	

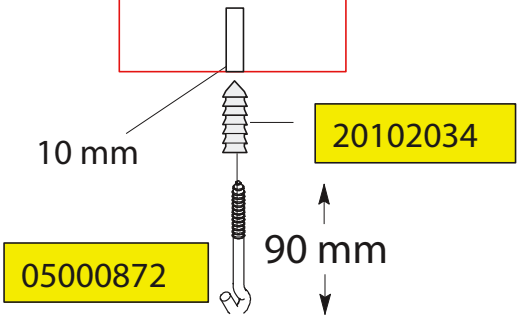
In a concrete beam
 <p>10 mm</p> <p>20102034</p> <p>05000872</p> <p>90 mm</p>
Drill a \varnothing 10 mm hole.

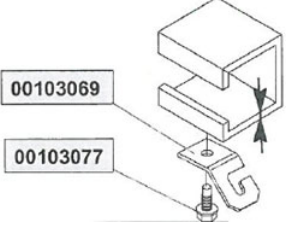
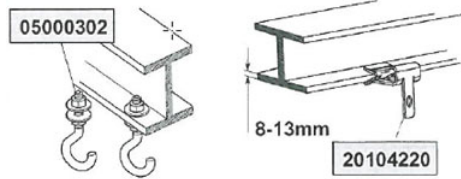
In metal	
Metal girder	Metal I girder
 <p>00103069</p> <p>00103077</p> <p>Profile thickness: 2.5 – 6 mm</p>	 <p>05000302</p> <p>8-13mm</p> <p>20104220</p>

Suspension in a house with separated pens

- 1 Provide a straight-line suspension through the separation walls.
- 2 Use a hole saw to make holes in the walls.
- 3 Put the tube exactly in the centre of the hole to avoid wear by friction with the wall.

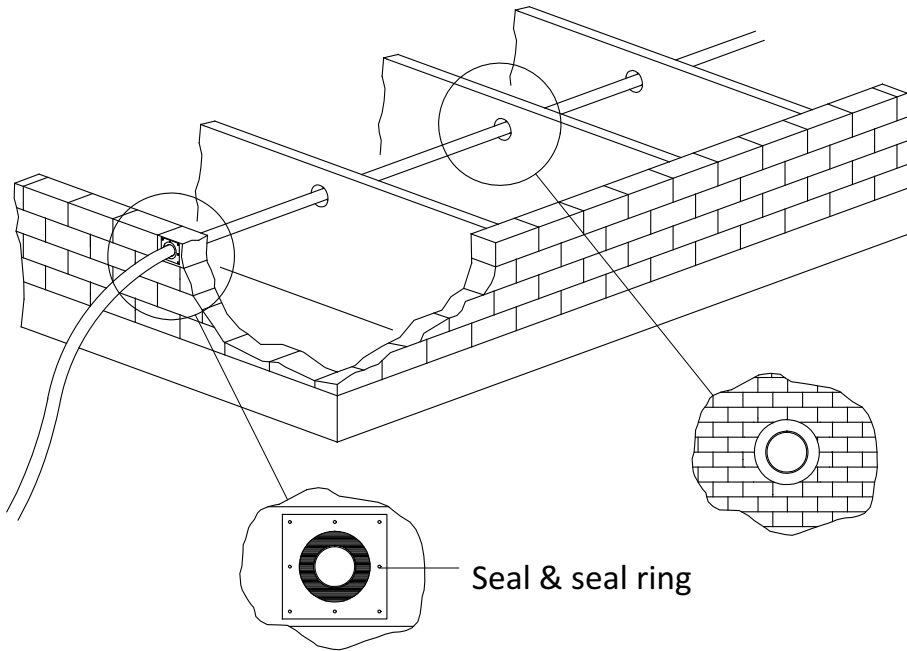

i **ATTENTION:** Pay attention to the difference in levels when using an extension boot: last part 23 cm lower! See Option: To install the extension boot.

Option: To install the suspension profile

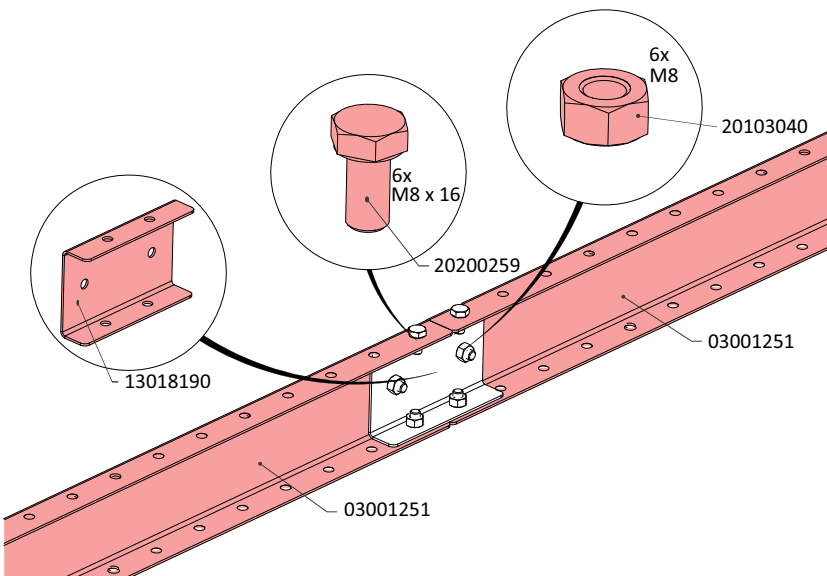

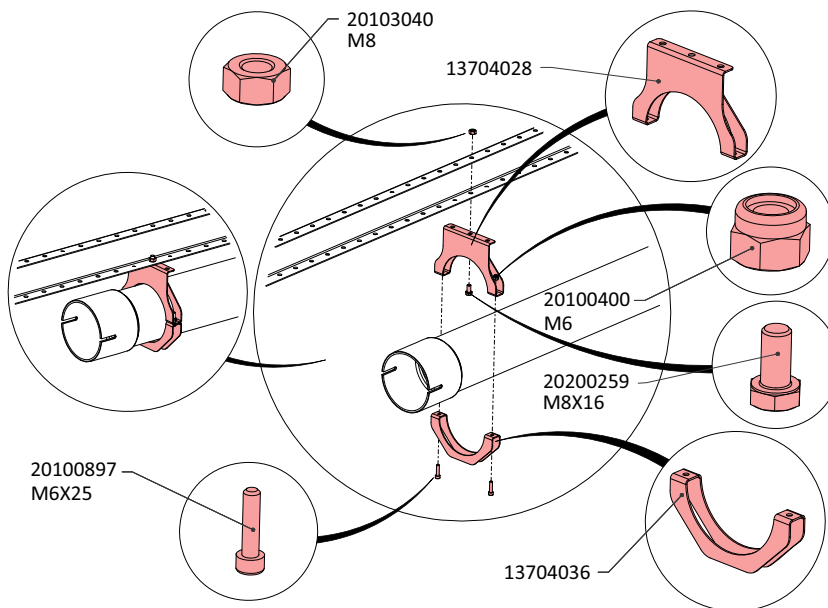
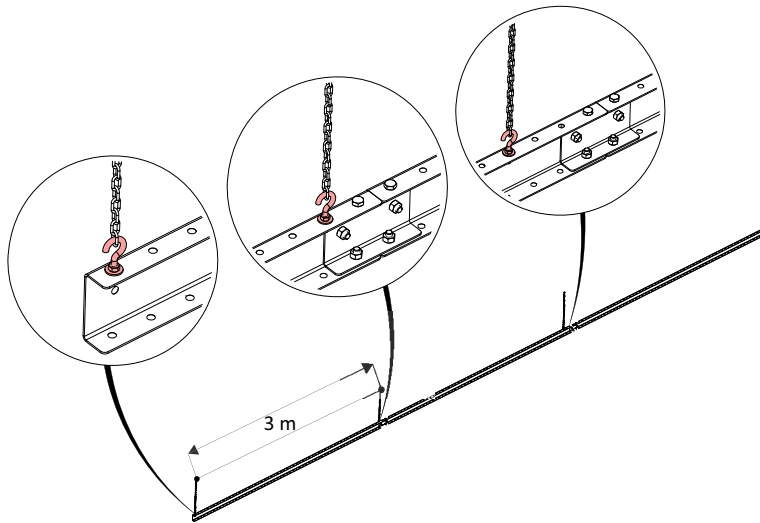
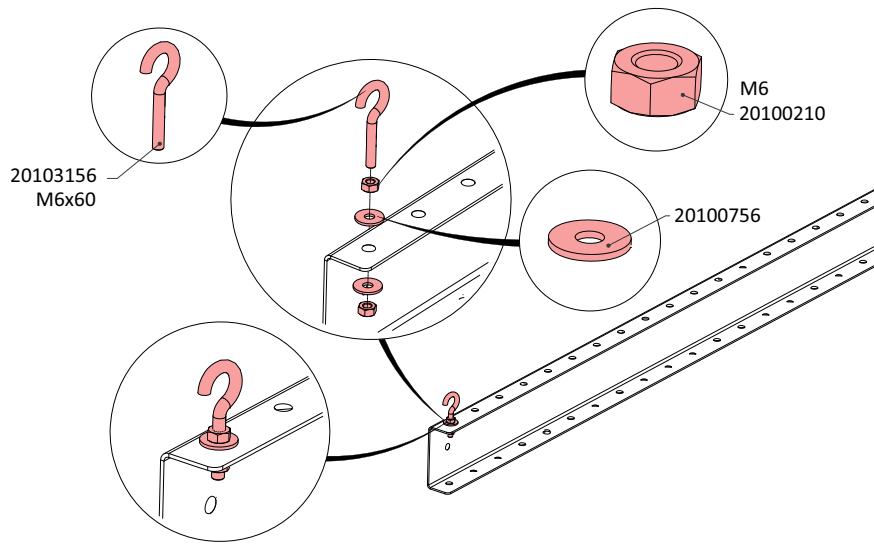

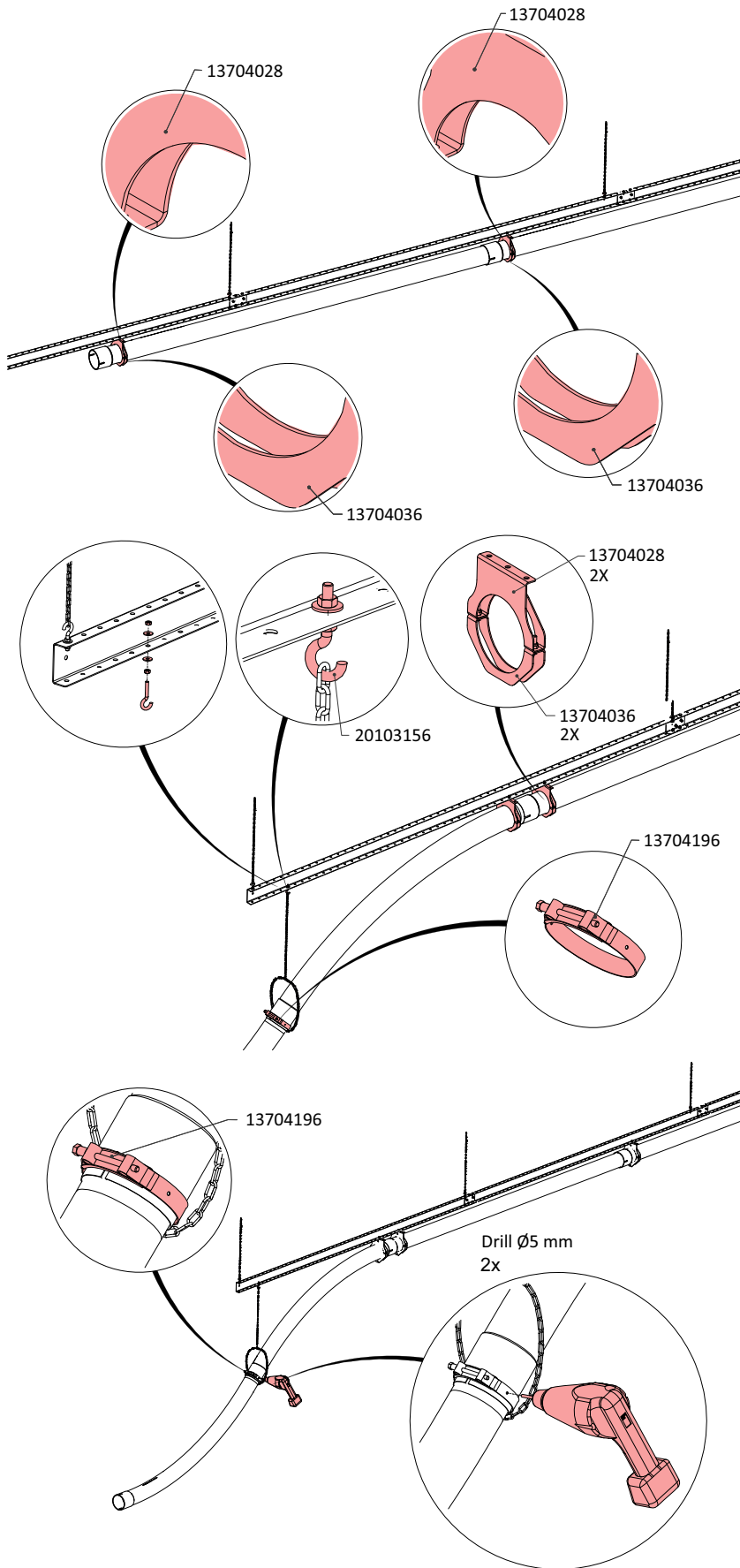

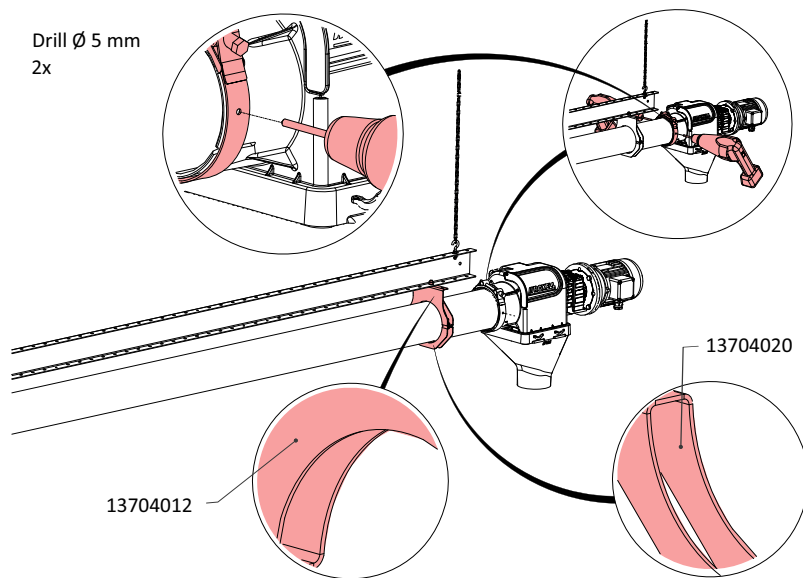
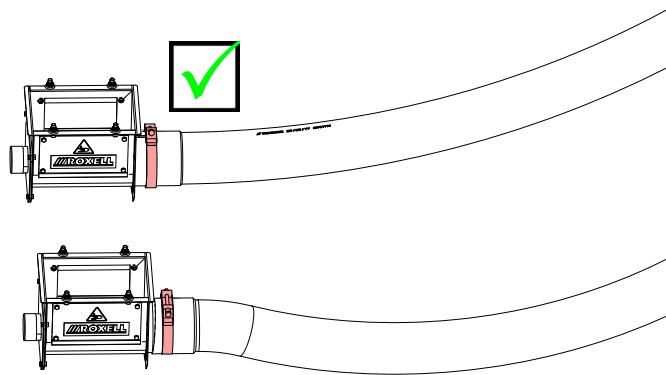
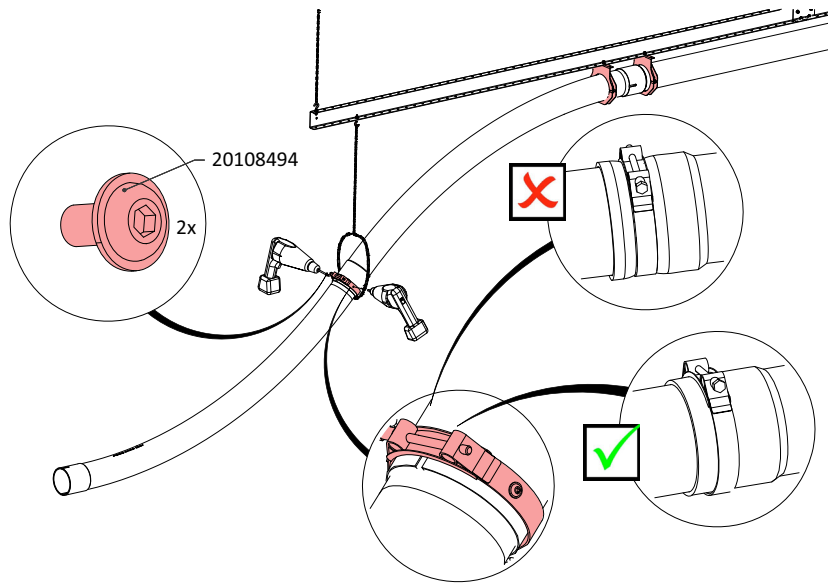

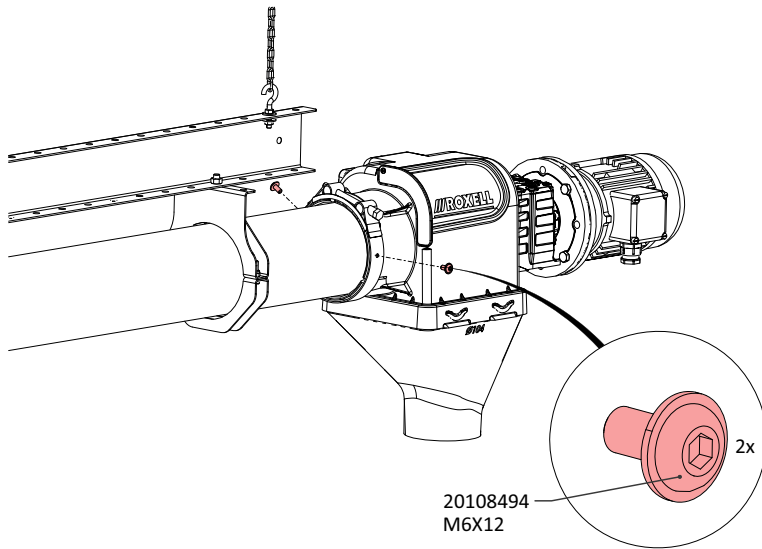

Control units

To assemble and install the single control unit

- 1 Fix the metal reinforcement plate at the inside.
- 2 Fix the power unit (on the opposite side of the tube anchor) to the control unit (with reinforcement plate) with the 4 bolts M8X20 supplied.

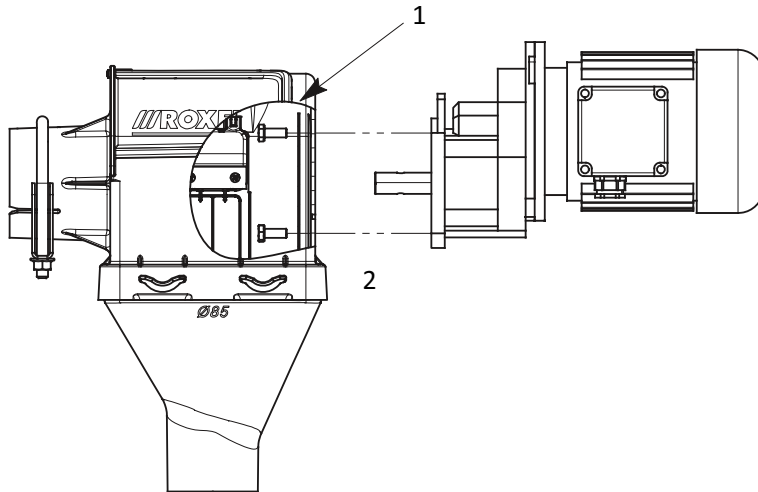

- 3 Suspend the control unit (B) at the proper location, in line with the tubes, so that the drop tube of Ø85 mm comes in the centre of the line (A).
- 4 Use the chain and S hooks at both suspension points:
 - 1 before the control unit (C)
 - 1 at the power unit (D)

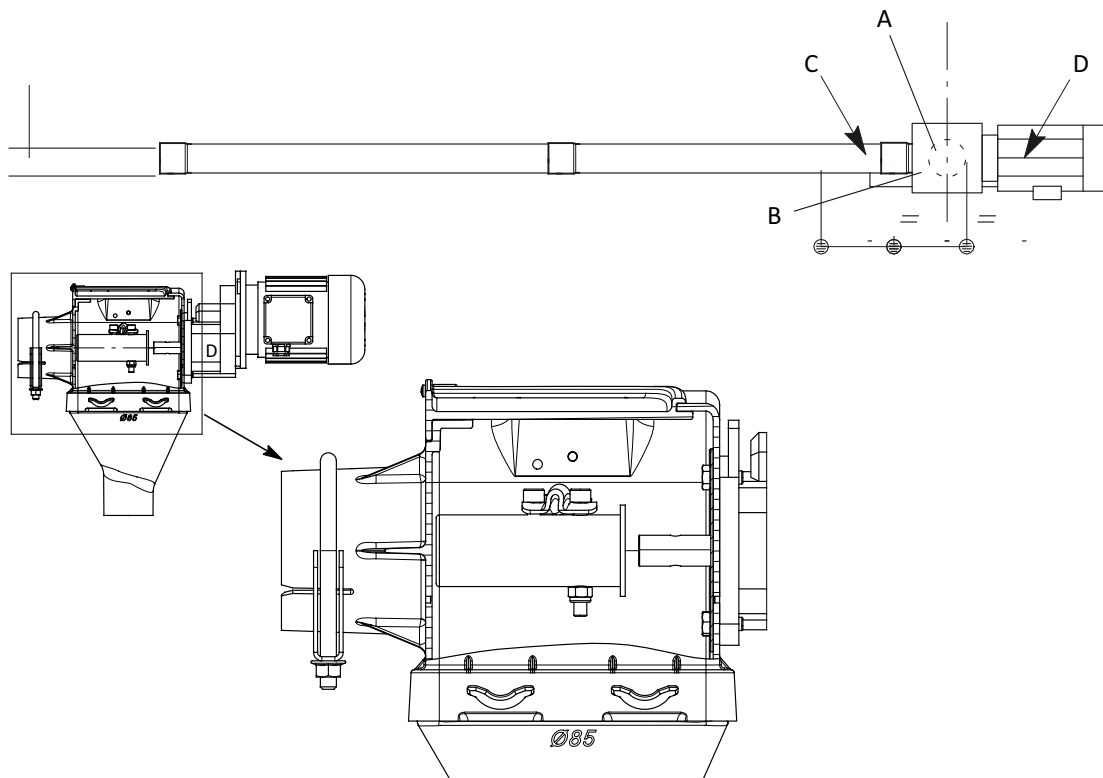

- 5 Slide the auger anchor over the gear-head shaft.
- 6 Tighten the screws, but leave the anchor block loose to install the auger.

To assemble and install the multiple control unit

For 2 supply Flex-Augers

i ATTENTION: There is 1 common safety switch (A) for all motors.

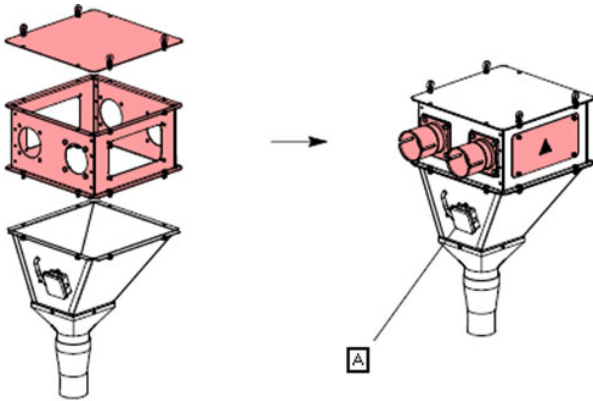

For more than 2 supply Flex-Augers

i ATTENTION: If there are more than 2 supply Flex-Augers: Install the extension for modular control unit on the standard unit for modular control unit.

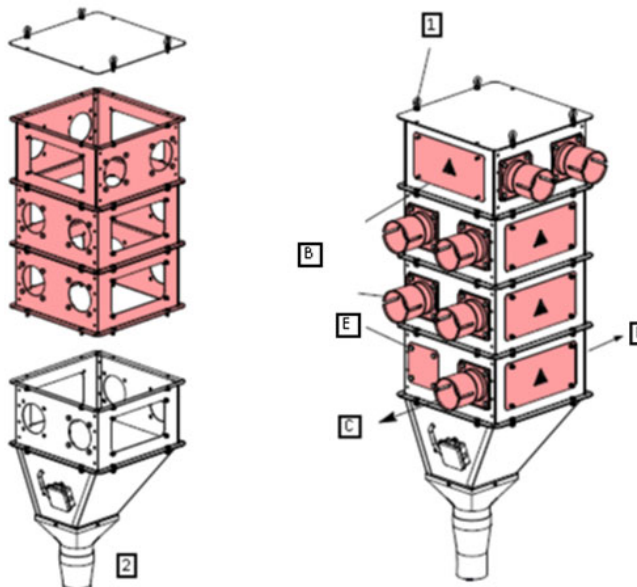

1. Fix the control unit to the four suspension eyes.
2. Fix the power unit.

i ATTENTION: Suspend each power unit separately.

Reference	Description
A	Safety switch
B	Flex-Auger hardware kit accessories
C	Flex-Auger
D	Motor
E	<ul style="list-style-type: none"> • FA 55: 04904736 • FA 75: 04904744 • FA 90: 04904751 • FA 125: 04904759

Option: To install the extension boot

- 1 Suspend the extension boot the same way as the control unit.
- 2 Point the slide towards the house passage.
- 3 Fix the extension boot underneath with 4 Parker screws.
- 4 Suspend the extension boot before the middle of the line (bin – control unit).

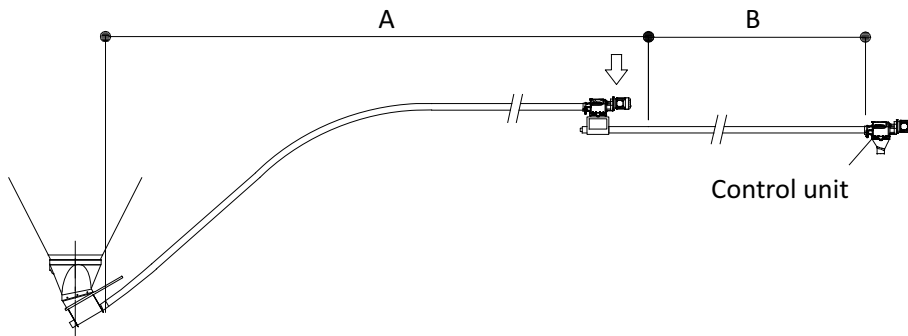

- 5 Ensure that the line past the extension boot hangs 23 cm lower (in standard extended system).

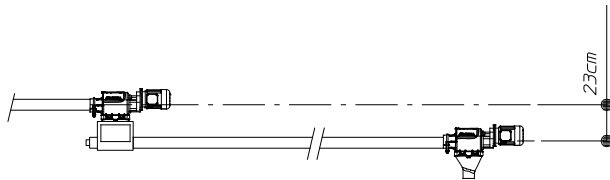

- 6 If you absolutely need an extra elbow in the system:

- Always install the **extension boot before** this elbow.
- Always install the **outlets behind** this elbow.

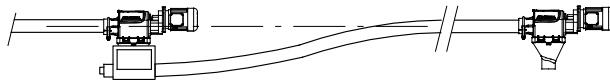

NOTE: To compensate the difference in levels, you can install two small elbows.

RESULT: With an extension boot, you can turn the line **90° left or right and save an elbow.**

Model 55/75/90: Chain	Model 125: Profile

Tubes

To make the drop holes in the tubes

Drop hole dimensions



ATTENTION:

- Use a hole saw.
- Ensure that the holes in a tube are well aligned.
- If you only have a hand saw or a grinder available, make square holes in the tubes.

Flex-Auger	Diameter	L x W
Model 55	40 mm	40 mm x 40 mm
Model 75	60 mm	60 mm x 60 mm
Model 90	76 mm	76 mm x 76 mm
Model 125	108 mm	108 mm x 108 mm

Distances between drop holes



ATTENTION: If you have two rows of feed troughs: Install the outlets in pair at the following distances:

Flex-Auger	Minimum distances between drop holes (X)
Model 55	106 mm
Model 75	116 mm
Model 90	125 mm
Model 125	250 mm

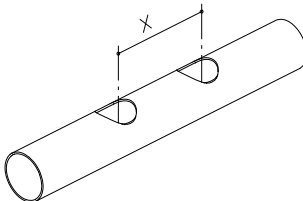

Hole for maximum feed drop out

Flex-Auger	Max. hole length (L)	Max. hole width (W)
Model 55	70 mm	40 mm
Model 75	80 mm	60 mm
Model 90	80 mm	76 mm
Model 125	108 mm	108 mm

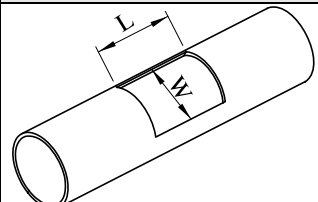

To install the tubes

Tubes



ATTENTION:

- Always start from the control unit.
- Never use an outlet to connect the tubes.
- Tighten the bolts by at least 10 Nm.

Model 55

Insert the end without sleeve of a $\varnothing 55$ mm tube into the tube anchor weldment.

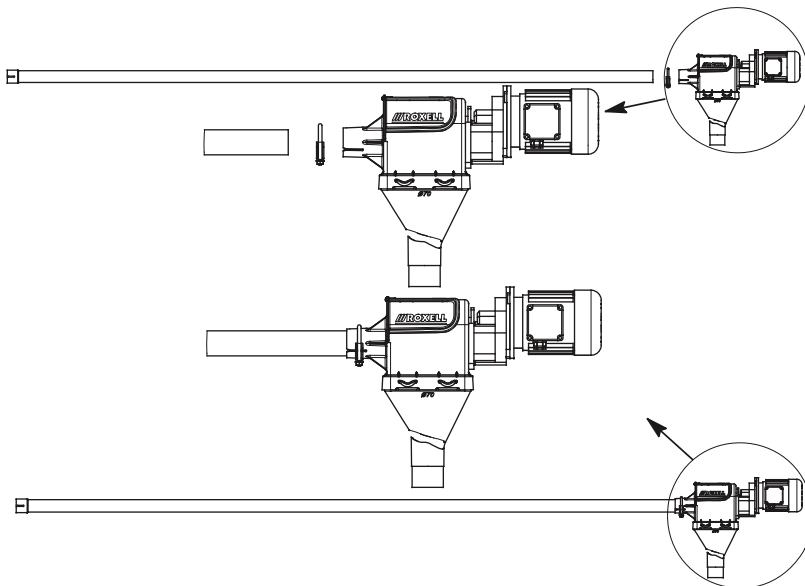

Model 75

Insert the end without sleeve of a $\varnothing 75$ mm tube into the tube anchor weldment.

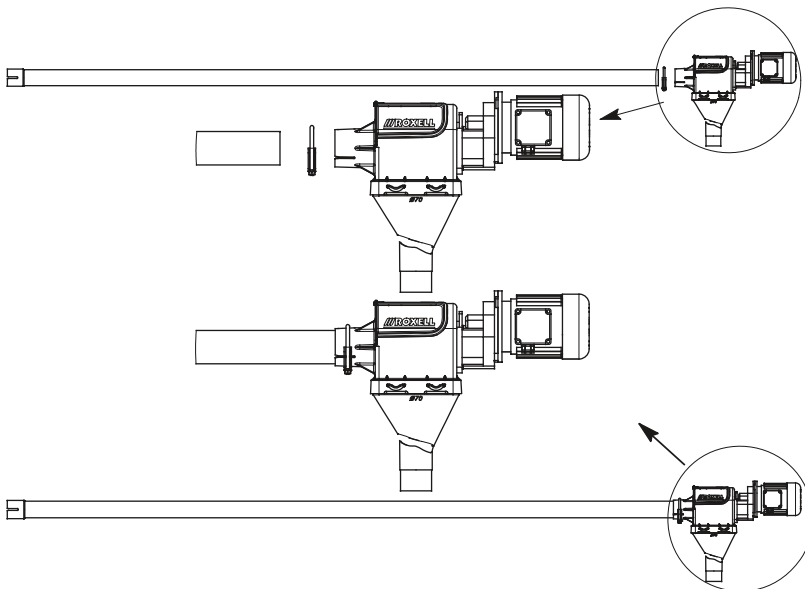

Model 90

Insert the end without sleeve of a $\varnothing 90$ mm tube into the tube anchor weldment.

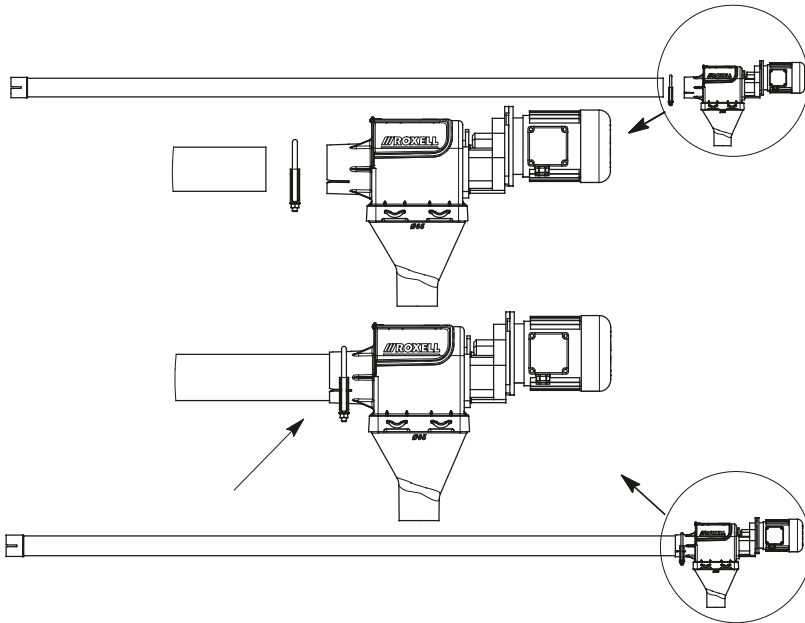
**Model 125**

Insert the end without sleeve of a $\varnothing 120$ mm tube into the tube anchor weldment.

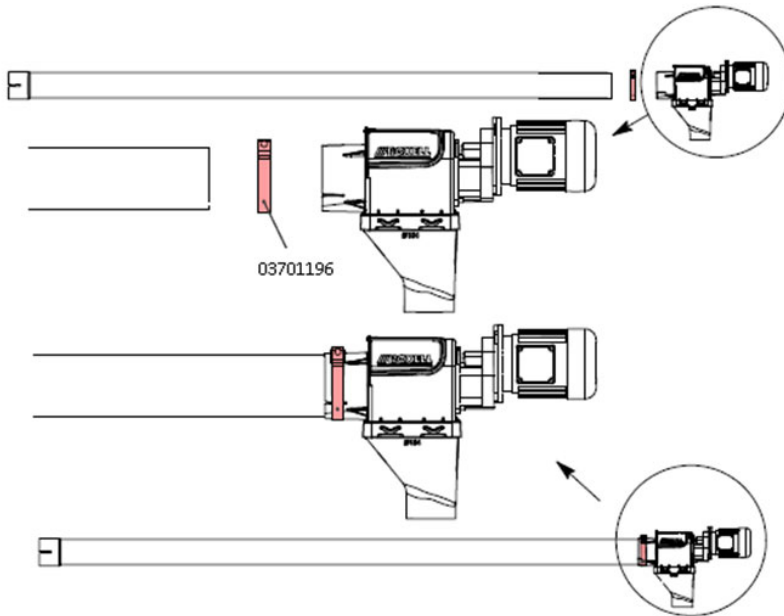

ATTENTION: Ensure that the drop holes:

- Point downwards.
- Are in a straight line.
- Are in the centre of the outlet.

Tube clamps

- Install the tube clamps as shown to obtain a strong connection.

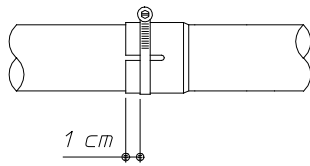

- Firmly tighten tube clamps at the right time with the right torque (minimum 10 Nm.).
- Do not deform the tubes.

Suspension loop

You can adjust the height of the transport line with the loop.

i **ATTENTION: Suspend all the tubes perfectly level.**

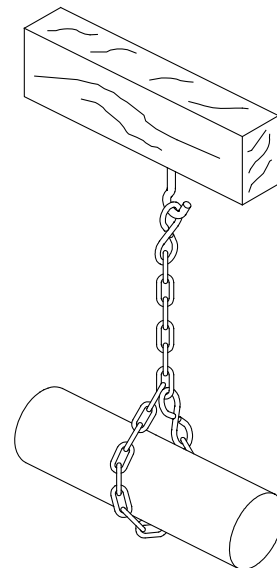
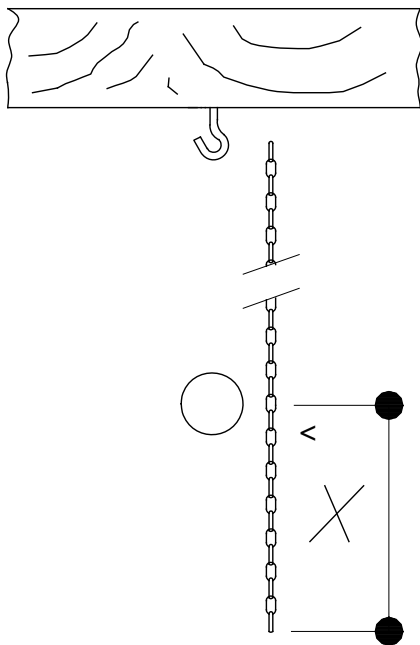

Extra chain length for suspension loop	
Model 55 and 75	X = 40 cm
Model 90 and 125	X = 60 cm

Continue this way until you can determine where to make the hole for the tube in the wall. Only now can you mount the boot underneath the bin.

To mount the outlets

- Before you install the outlets, install the complete transport system.
- Ensure that no tube connectors are mounted above the intake boots.
- Ensure that the transport system is not located right above the intake boots, but rather as shown on the drawing.

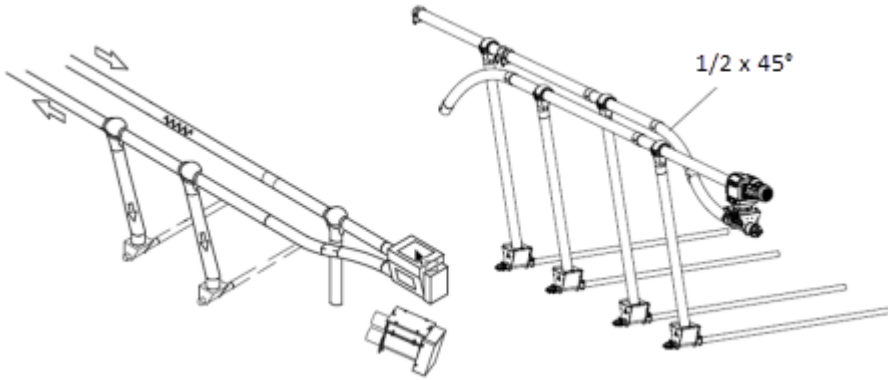

- 1 Knot the rope in the middle.

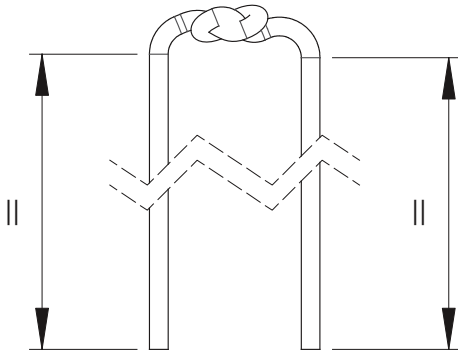

- 2 Slide the cord through the shut-off plate. Make a second knot.

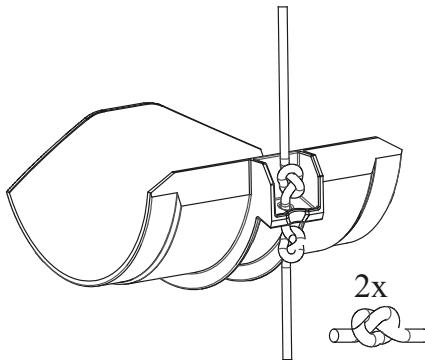

- 3 Mount the closing slide in the correct position.

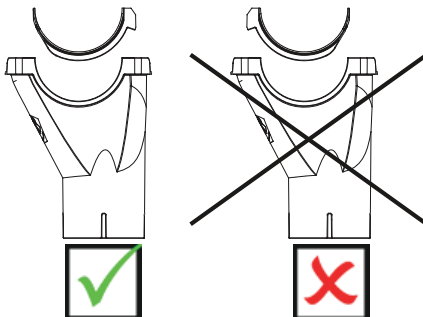

- 4 Push four screws by hand into the mounting holes.

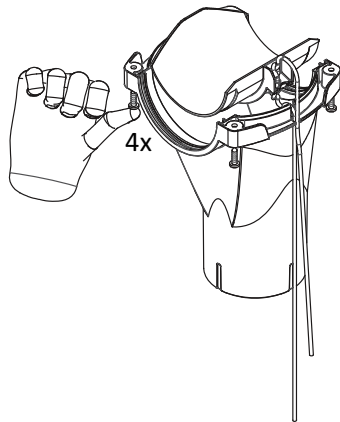

- 5 Position the bottom piece to the tube.

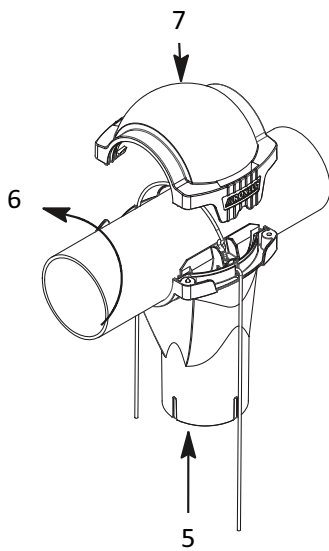

- 6 Put the cord over the tube.
- 7 Click the top piece to the outlet.

8 Slide the cord ends through the small balls and make knots.

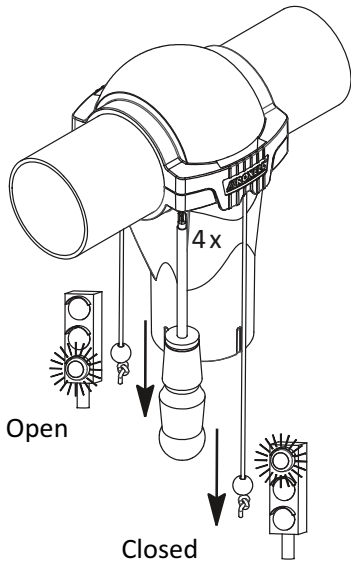

9 Fix the drop tube with one Parker screw. Ensure that the screw is not in the feed flow.

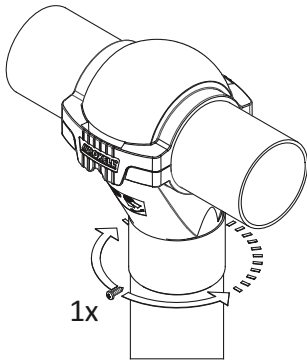

Example:

Model 125	Angled mounting
	<ul style="list-style-type: none"> • Meal: max. 30° • Pellets: max. 45°

To mount the automatic outlet



DANGER: The automatic outlet starts automatically. Never put your hands in the outlet or drop holes before you:

1. Completely turn off the transport system.
 2. Ensure that nobody can turn on the system without your knowledge.
-
1. Fix the drop to the outlet.

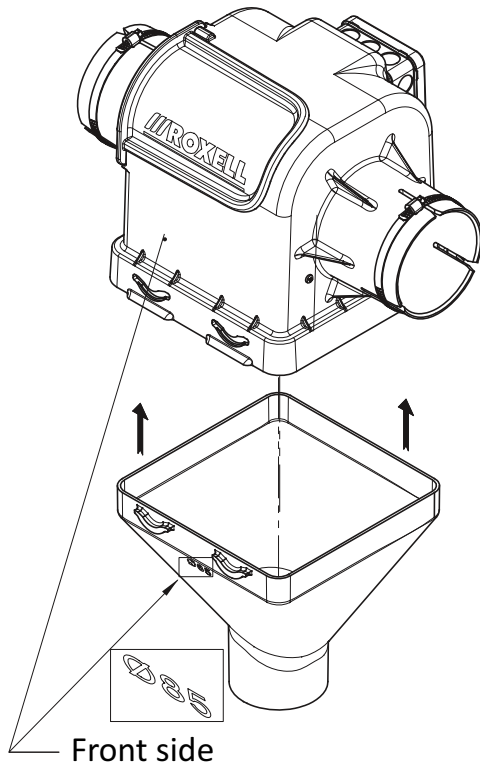

2. Ensure that the drop is properly clicked into place.

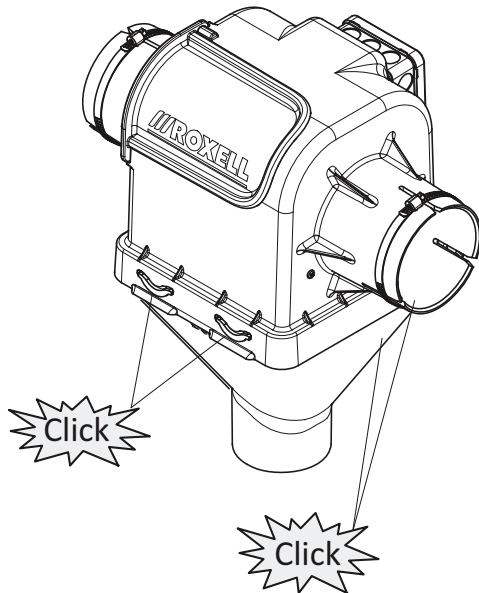

- 3 Fix the intake boot to the wall, the ceiling or the floor, in such a way that it cannot move.

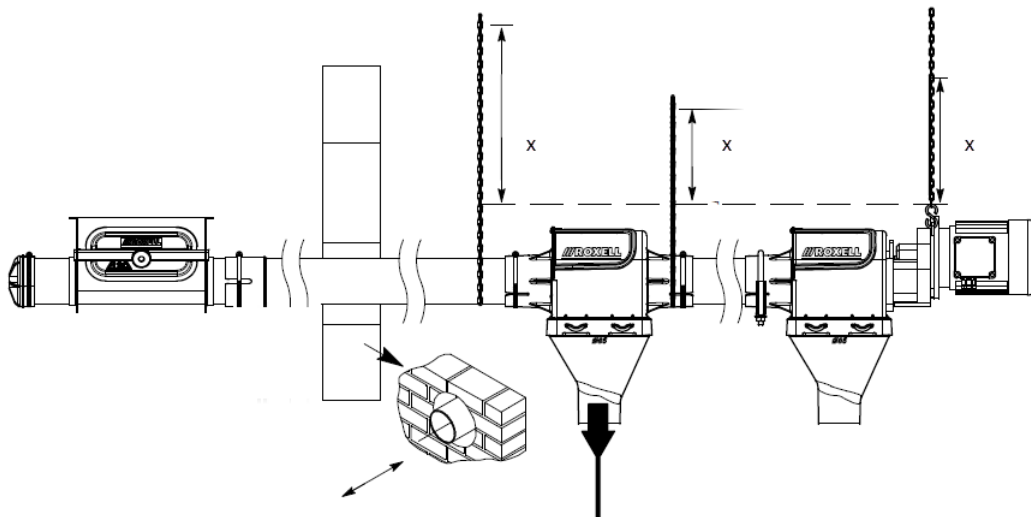

i NOTE: $x = \text{min. } 500 \text{ mm}$

- 4 Install the Flex-Auger horizontally. The line must be able to move freely.
5 Install the automatic outlet at 90°.

i NOTE: If the suspension chain is shorter than 500 mm, follow the installation instructions for Flex-Augers longer than 30 m.

If you install 2 Flex-Augers in series:

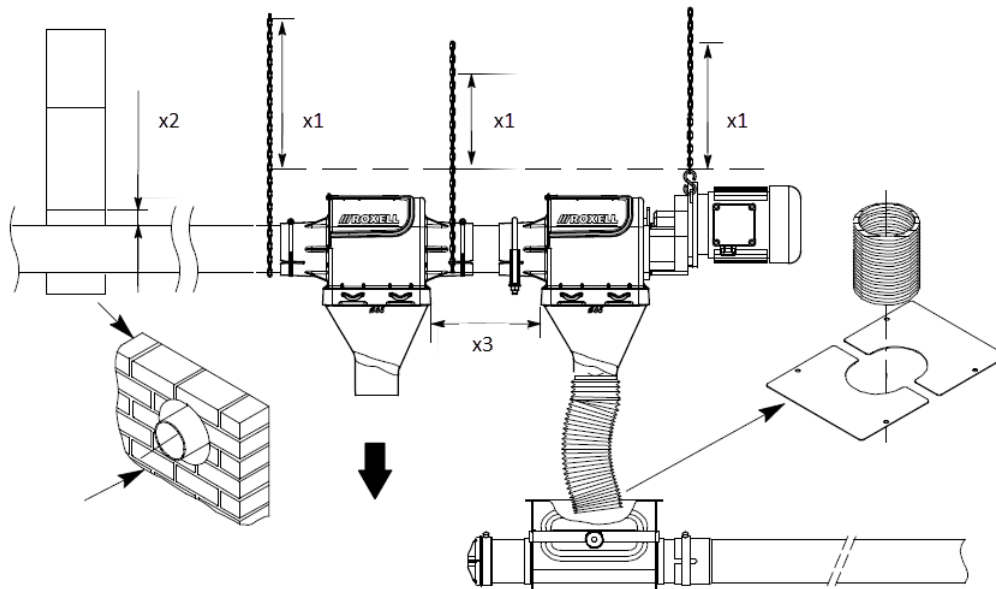

i NOTE:

- $x1 = \text{min. } 500 \text{ mm}$
- $x2 = \text{min. } 1,5 \text{ mm}$
- $x3 = \text{min. } 250 \text{ mm}$

- 6 Install the Flex-Auger horizontally. The line must be able to move freely.
7 Install the automatic outlet at 90°.
8 Fix the intake boot to the wall, the ceiling or the floor, in such a way that it cannot move.

To remove the automatic outlet

- 1 Push on the drop.
- 2 Push a screwdriver between the drop and the outlet.

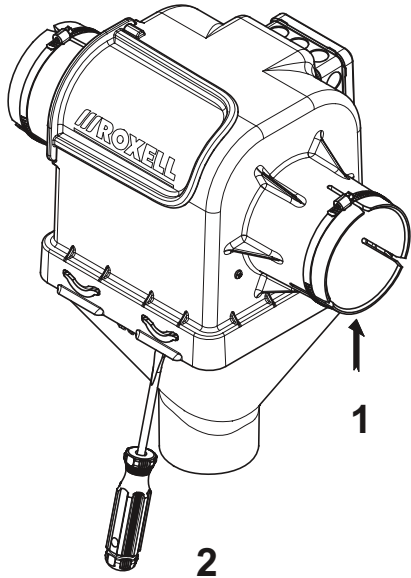

- 3 Move the screwdriver.
- 4 Pull the outlet.

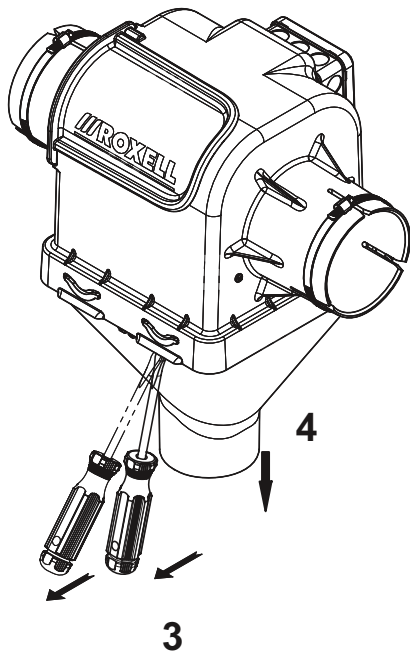

Boot assembly

To install the boot assembly – survey

- 1 Slide the upper boot (in correct position) as far as possible in the bin collar
- 2 Drill 8 holes of $\varnothing 9$ mm (3/8").
- 3 Place the transfer plate in the direction of the transport line.
- 4 If you use a pellet kit, install it together with the intake boot.

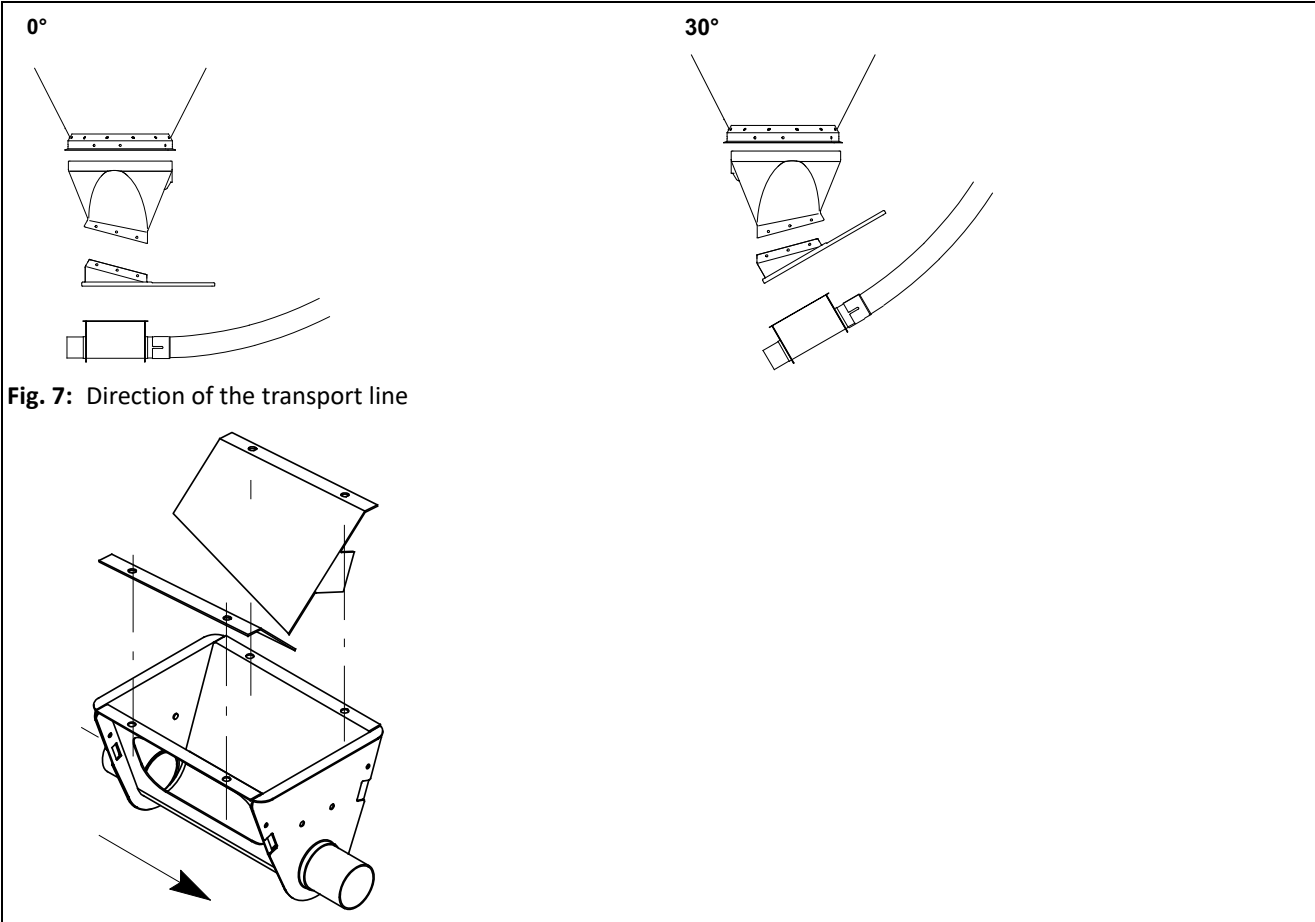

To install the boot assembly – example upper boot 0°

Drawing	Reference	Description
	A	Seal cap
	B	Nut M8 PA6 black
	C	Bin collar
	D	8 M8X20
	E	Upper boot
	F	8 holes of Ø9 mm
	G	Nut M8 PA6 black
	H	Nut M8
	I	10 hexagon socket head cap screws M8X25
	J	Intake boot
	K	4 socket cap screws M8X25
	L	Transfer plate

- 1 Slide the upper boot as far as possible in the bin collar.
- 2 Ensure that the lower part of the boot points in the direction of the transport line.
- 3 Drill a hole of Ø9 mm (see 1 on the drawing). Fix by hand with the bolt and the nut.

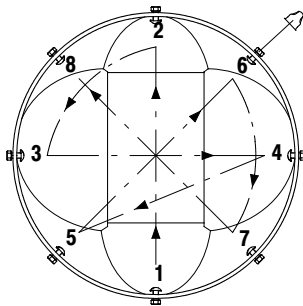

- 4 Drill the opposite hole (2). Fix by hand with the bolt and the nut.
- 5 Drill a hole at 90° (3)
- 6 Drill the opposite hole (4). Fix by hand with the bolt and the nut.
- 7 Proceed in the same way for the other fixing points (5–8).
- 8 Use a ring spanner to tighten all the nuts with a moment of 4 Nm in the same sequence (1–8). Do not tighten too much (cracks)!
- 9 Mount the seal caps.



ATTENTION: Flex-Auger 125: First check the sense of rotation of the auger, then install the thumper.

To install the quadruple boot assembly

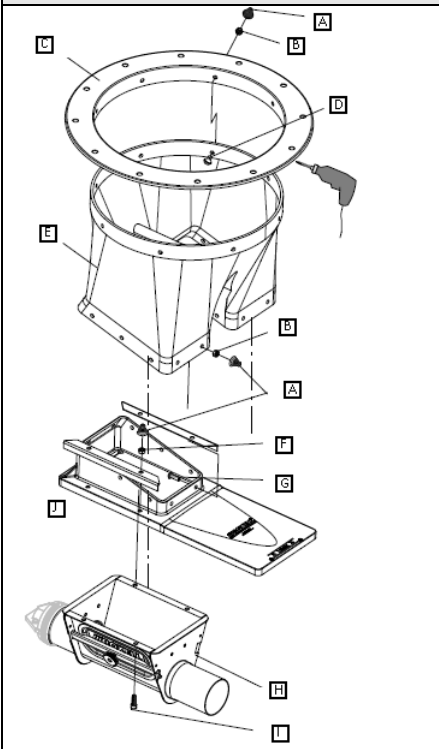
Drawing	Reference	Description
	A	Seal cap
	B	Nut M8 PA6 black
	C	Bin collar
	D	8 M8X20
	E	Upper boot
	F	Nut M8
	G	10 hexagon socket head cap screws M8X25
	H	Intake boot
	I	4 socket cap screws M8X25
	J	Transfer plate

- 1 Slide the upper boot as far as possible in the bin collar.
- 2 Ensure that the lower part of the boot points in the direction of the transport line.
- 3 Drill a hole of $\varnothing 9$ mm (see 1 on the drawing). Fix by hand with the bolt and the nut.

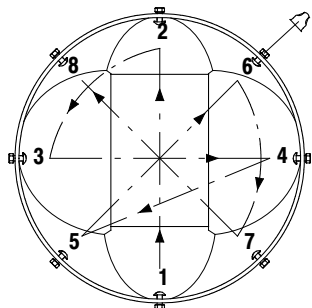

- 4 Drill the opposite hole (2). Fix by hand with the bolt and the nut.
- 5 Drill a hole at 90° (3)
- 6 Drill the opposite hole (4). Fix by hand with the bolt and the nut.
- 7 Proceed in the same way for the other fixing points (5–8).
- 8 Use a ring spanner to tighten all the nuts with a moment of 4 Nm in the same sequence (1–8). Do not tighten too much (cracks)!
- 9 Mount the seal caps.

i **ATTENTION: Flex-Auger 125: First check the sense of rotation of the auger, then install the thumper.**

RESULT:

i **NOTE:** You can turn the intake boot 180° .

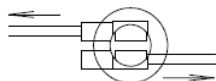

To install the multiple boot assembly

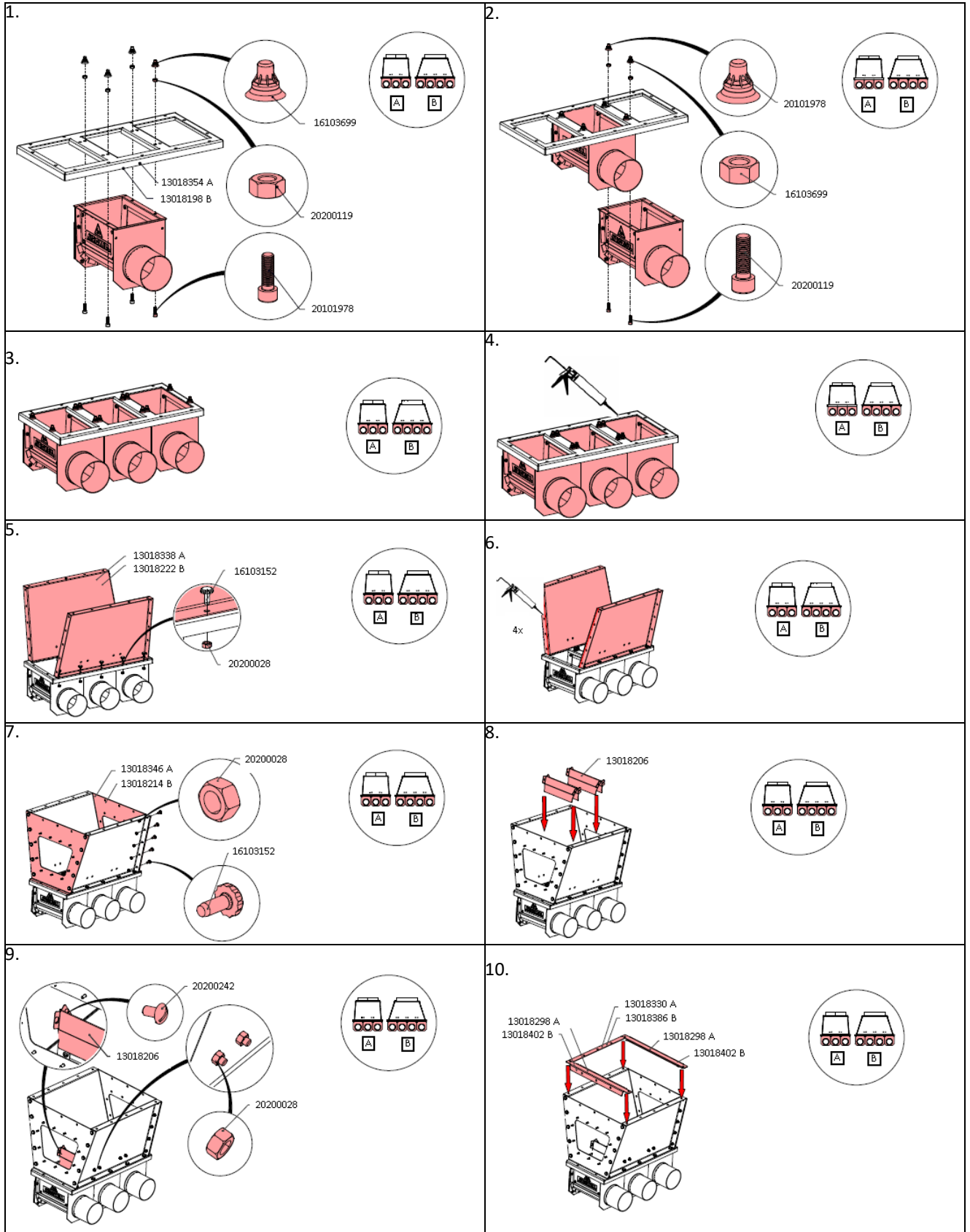

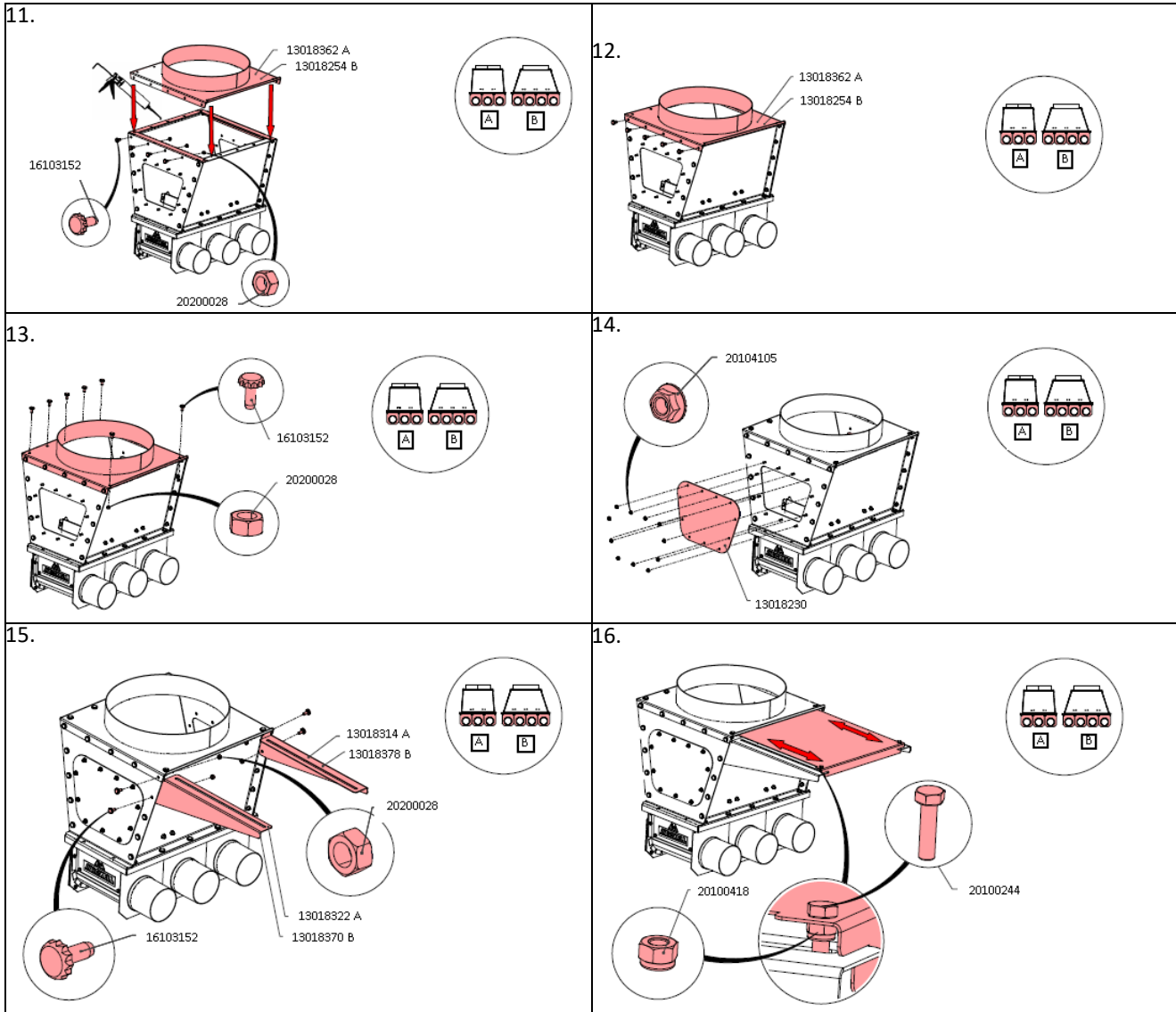

Connection of the transport system to the bin

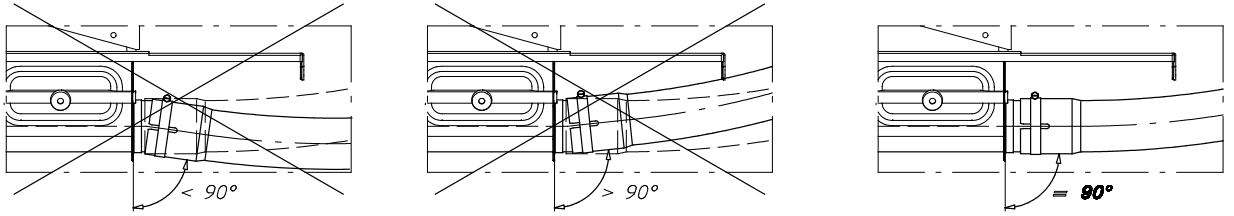

Fig. 8: model 90

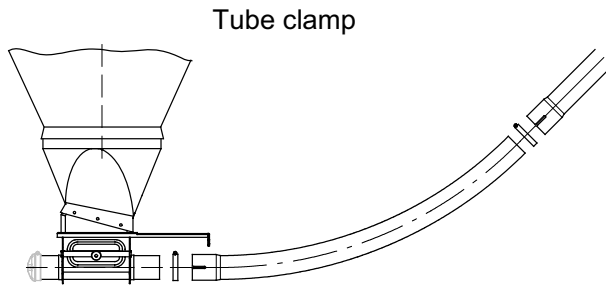

Fig. 9: model 75

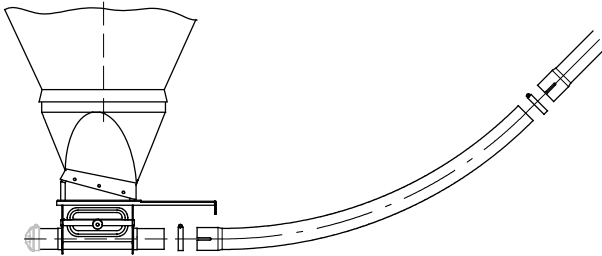

Fig. 10: model 55

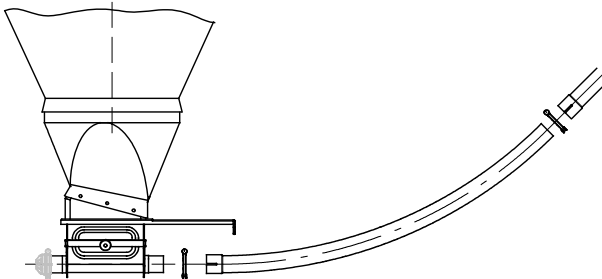
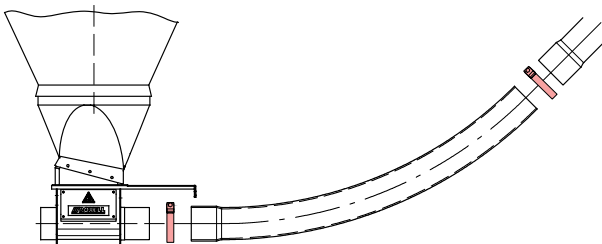
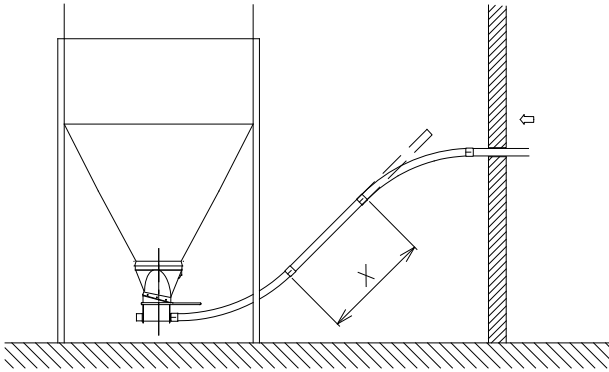

Fig. 11: model 125



- 1 Install the horizontal tube straight through the wall.
- 2 Install a 45° elbow pointed towards the bin boot.

- 3 Hold a tube between both elbows to determine the required length (X) of the straight tube.



- 4 Install the tubes outside with sleeve facing downwards to avoid water from leaking in.
 5 Cut the 45° elbow to obtain the correct inclination to the hole in the wall.

Boot at 0°	Boot at 30°
	<p>i ATTENTION: Not recommended. Not allowed for breeder application.</p>

- 6 Use caulking or silicone: Tube connections outside the house must be watertight.
 7 Slide the tube into the sleeve of the next tube or elbow.

Model 55, 75 and 90 with tube connector (option)

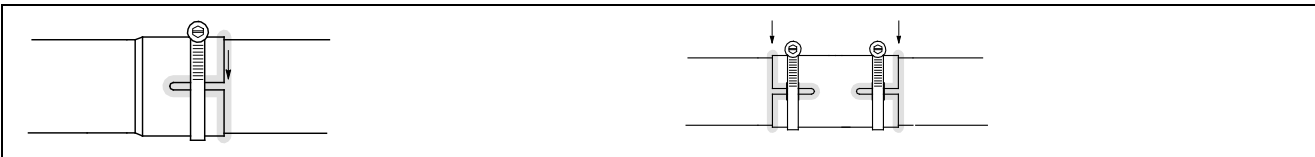

Model 125

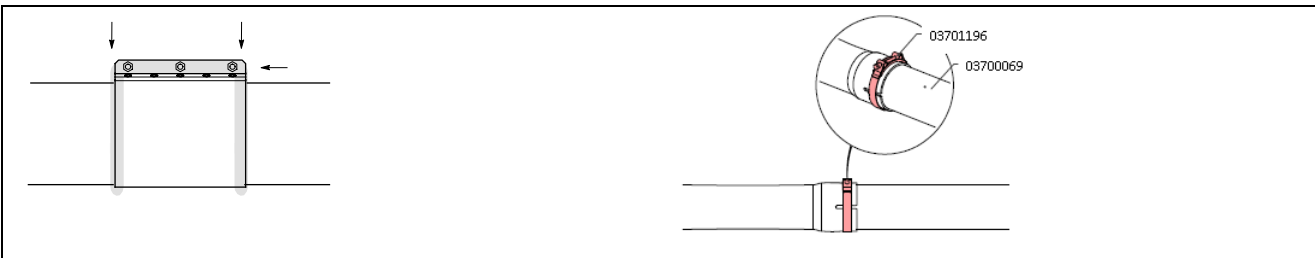

i **ATTENTION:** Tighten all bolts: minimum 10 Nm.

- 8 Support the tubes with two chains, so that the hopper does not carry the weight of the tubes.

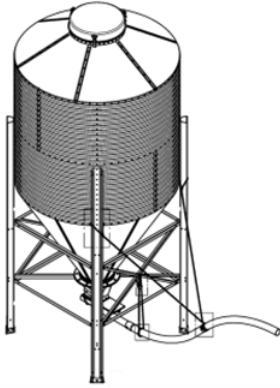

- 9 Fix the chain around the bin leg.

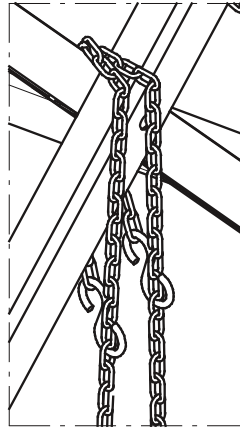
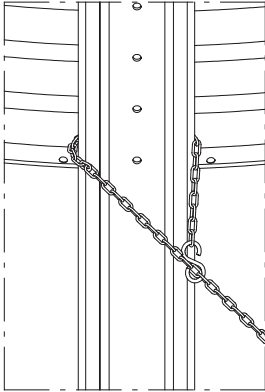

- 10 Wind the chain once around the tube.

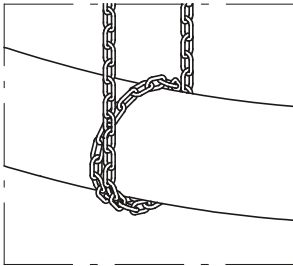

- 11 Put an S-hook between the tube and the tube clamp.

- 12 Fix the chain to the S-hook.

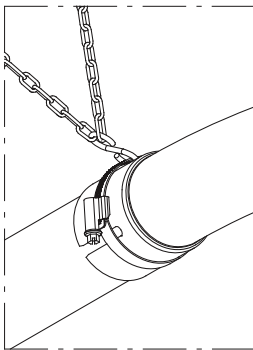

Auger

To install the auger

 **DANGER: Take care that the auger does not unroll!**

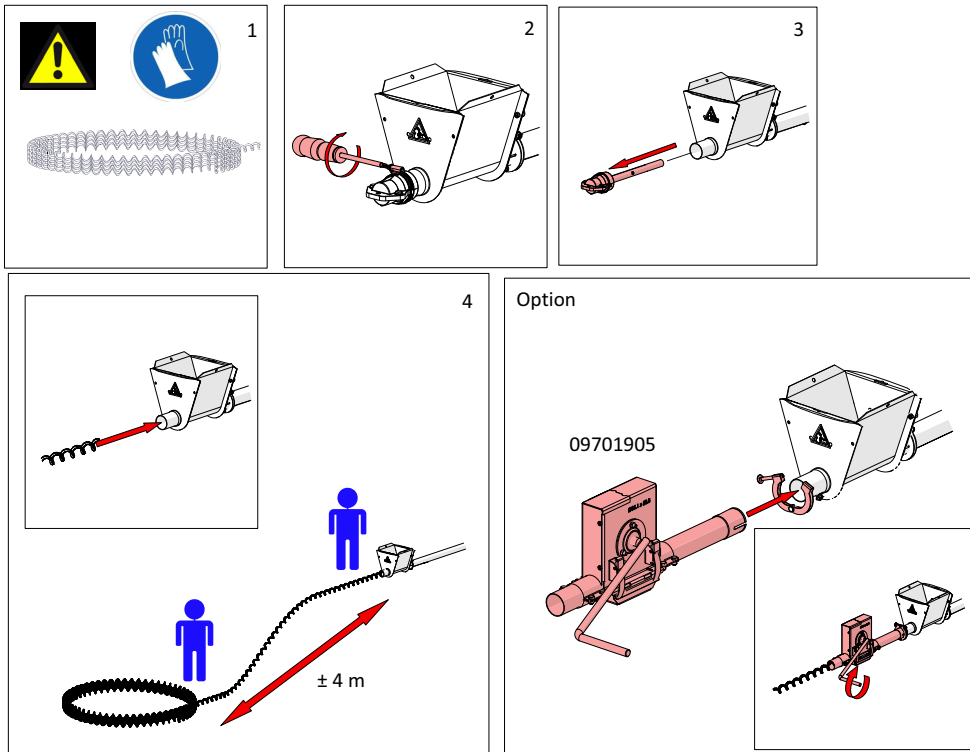

Auger brazing

 **ATTENTION:**

- Use a bronze, flux-coated rod.
- Always use hard solder.
- Fill up the weld joint well.
- Avoid sharp edges or rough corners: these wear out the tubes.
- Braze at low temperature.
- The weld length should be min. 1/4 of the auger circumference, up to max. 1/3 of the auger circumference.

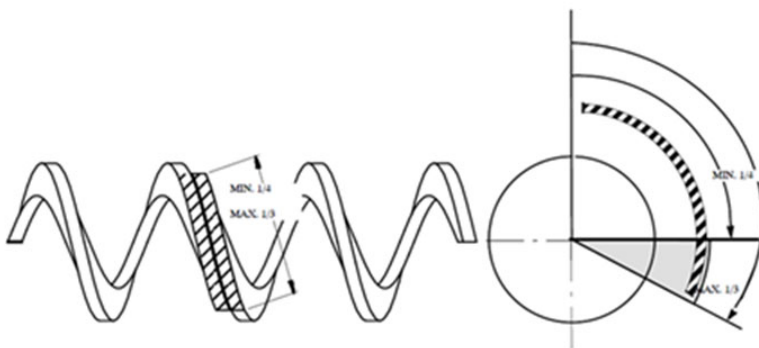

1. Firmly clamp the auger ends against one another, in one line, in an angle or channel iron.
2. Place the weld joint as closely as possible to the motor.



ATTENTION: Never place a joint in an elbow!

3. Let the weld joint cool down in the air: Rapid cooling makes the weld joint brittle and breakable.
4. Remove all sharp welding seams on the outer edges of the auger. These wear out the tube!

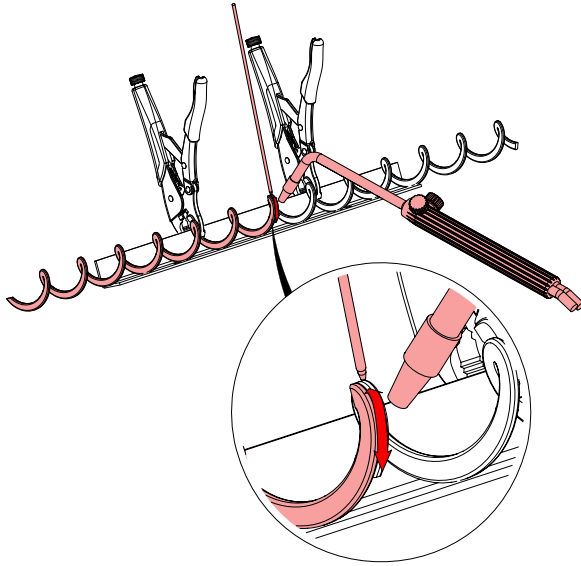

To connect the auger

To the power unit

Model 55	Models 75, 90, 125
<ol style="list-style-type: none"> 1. Use a 22 x 1.25 tube. 2. Clamp the auger under the anchor block. 3. Firmly tighten the bolt. 	<ol style="list-style-type: none"> 1. Clamp the auger under the anchor block. 2. Firmly tighten the bolt.

To the boot



DANGER: Always ensure that the auger cannot spring back by using clamps or a hammer in the boot.

1. Pull a few times at the auger, so it takes its natural length.
2. Mark the auger (M) at the rear of the boot.
3. Stretch the auger a double pitch and put a new mark (NM).
4. Cut the auger at this new mark.

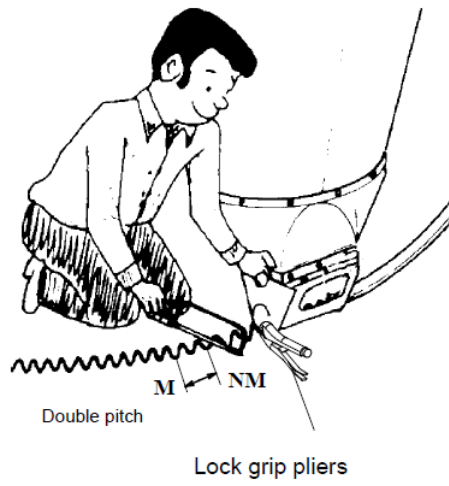
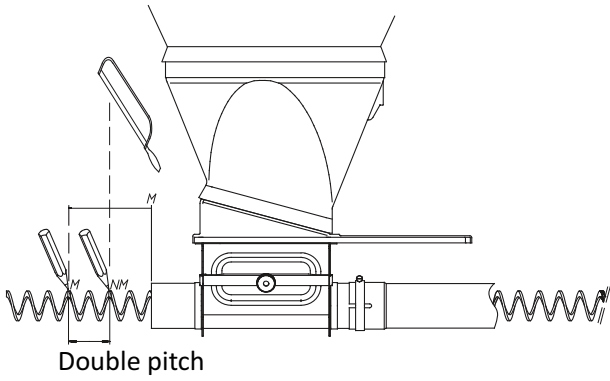

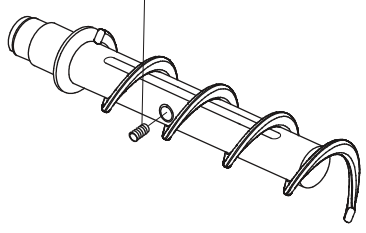
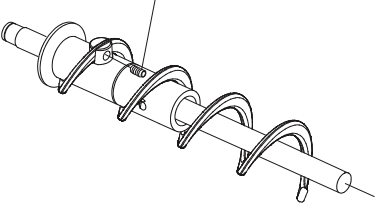
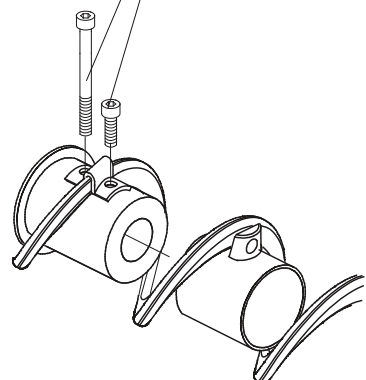
Model 55	Models 75, 90	Model 125
Firmly tighten the set screw.	Firmly tighten the set screw.	Firmly tighten the bolts.
		

5. Slowly slide the auger back into the tube.
6. Firmly fix with a tube clamp (models 55, 75, 90).

! DANGER: Never put tensile stress on the auger when you use Novicor tubes.

To mount the bearing cap holder

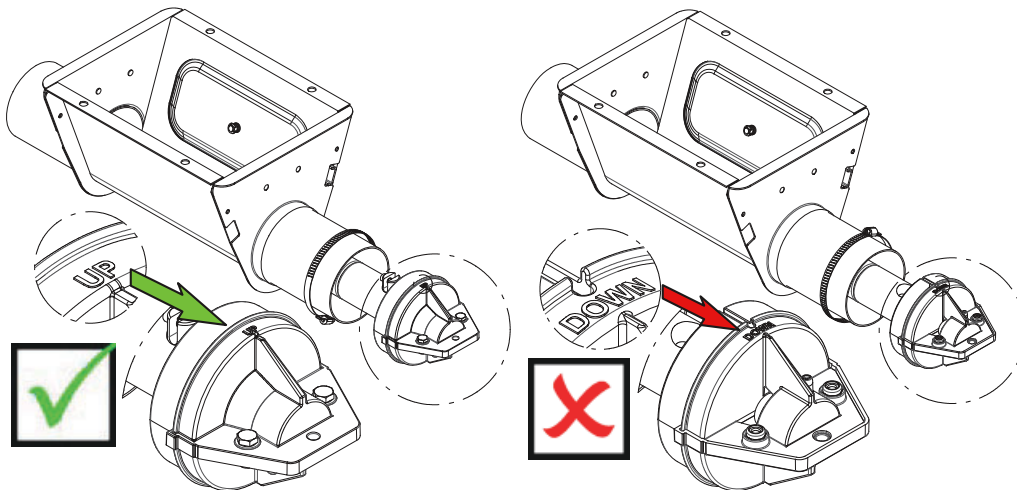

Option: Thumper

To assemble the thumper – model 55 / 75 / 90

Press the pre-punched holes through.

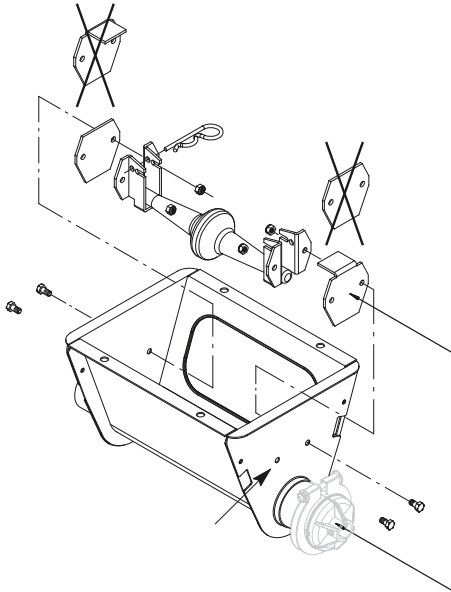

To install the thumper

- 1 Install the thumper on the right side of the boot (looking from the bin to the control unit).

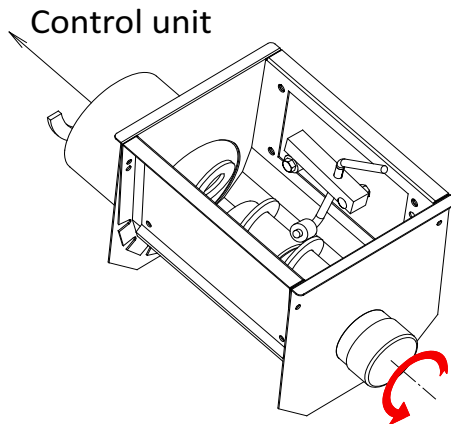

- 2 Check if the rotation direction of the auger is counterclockwise (looking from the bin to the control unit).
- 3 Install the transition plate in such a way that the slide is on the side of the control unit.
- 4 Lift up the thumper when you close the slide.



NOTE: You cannot close the slide when it is installed on the wrong side.

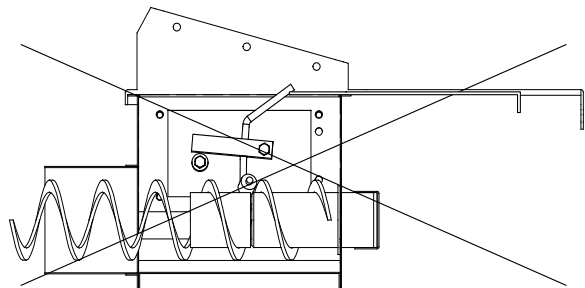
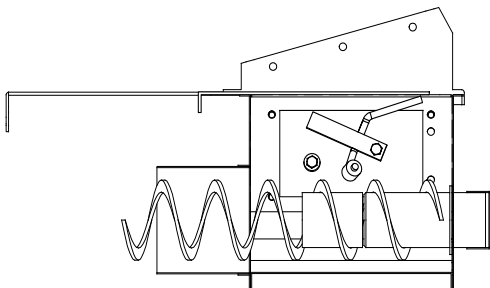

Flow regulation

Models 75 and 90

i **ATTENTION:** Check if the direction of rotation of the auger is counterclockwise looking from the bin to the control unit.

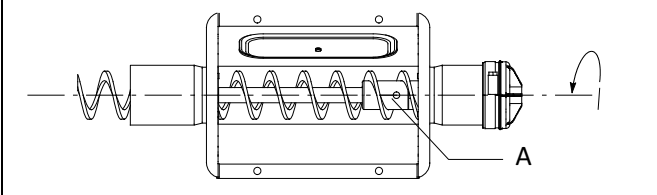
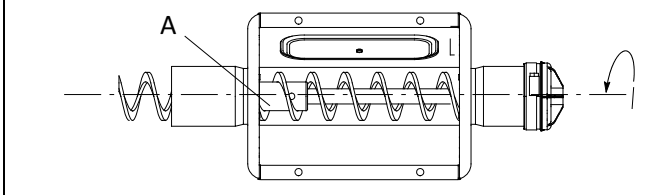
Maximum feed flow	Minimum feed flow
Flow regulator (A) open.	Flow regulator (A) closed.
	

i **NOTE:** If you use an extension boot, adjust the flow regulator in such a way that the second part of the line transports more feed than the first part.

Model 125

i **NOTE:** Flow regulator in the boot, as supplied standard.

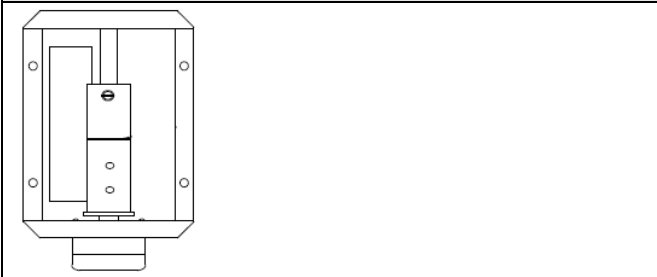
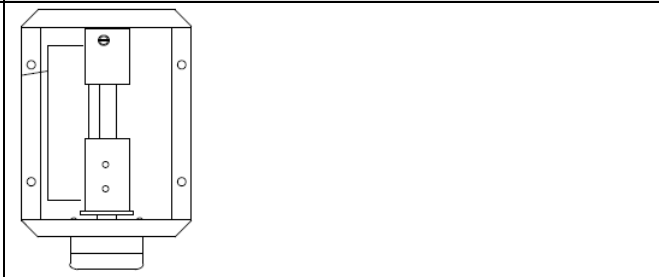
Maximum feed flow	Minimum feed flow
	

Drop tubes

To install the drop tubes

Without telescopic tube

Cut the drop tube to the exact length, to have the required amount of feed in the hopper.

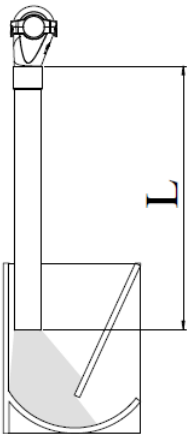

With telescopic tube

You can adjust the height of the drop tube in the feed trough or hopper individually and at any time.

Distance between feed trough bottom and drop tube: ± 1.1 m

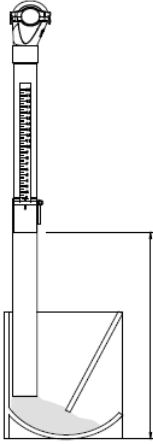

To adjust the telescopic tube:

- Put the telescopic tube in the feed trough at its lowest level.
- Place the measure decal with 1 at the upper end of the telescopic tube.



NOTE: With the decal, you can adjust the feed level in the trough and make comparisons between pens.

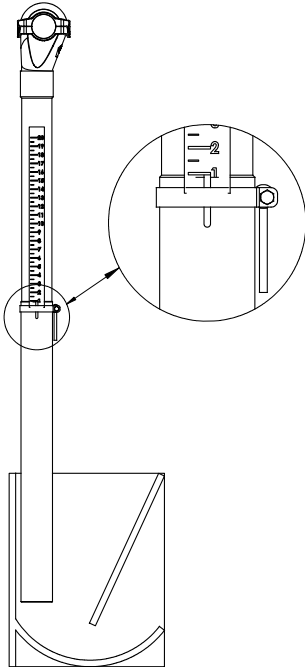

With flexible tube

The flexible tube is flexible in practically all directions.

i **ATTENTION: Do not forget the 2 Parker screws $\varnothing 4.2 \times 13$.**

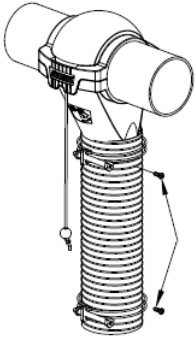

In chapel form

For well flowing mash and pellets	For difficult flowing feed

Use contact glue to fix the telescopic tube:

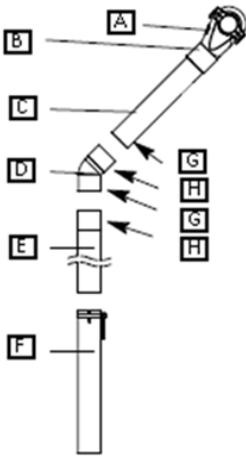

Reference	Description
A	Outlet
B	Parker screw
C	Drop tube
D	Elbow
E	Drop tube
F	Telescopic tube
G	Glue outside
H	Glue inside

To install the control unit drop tube

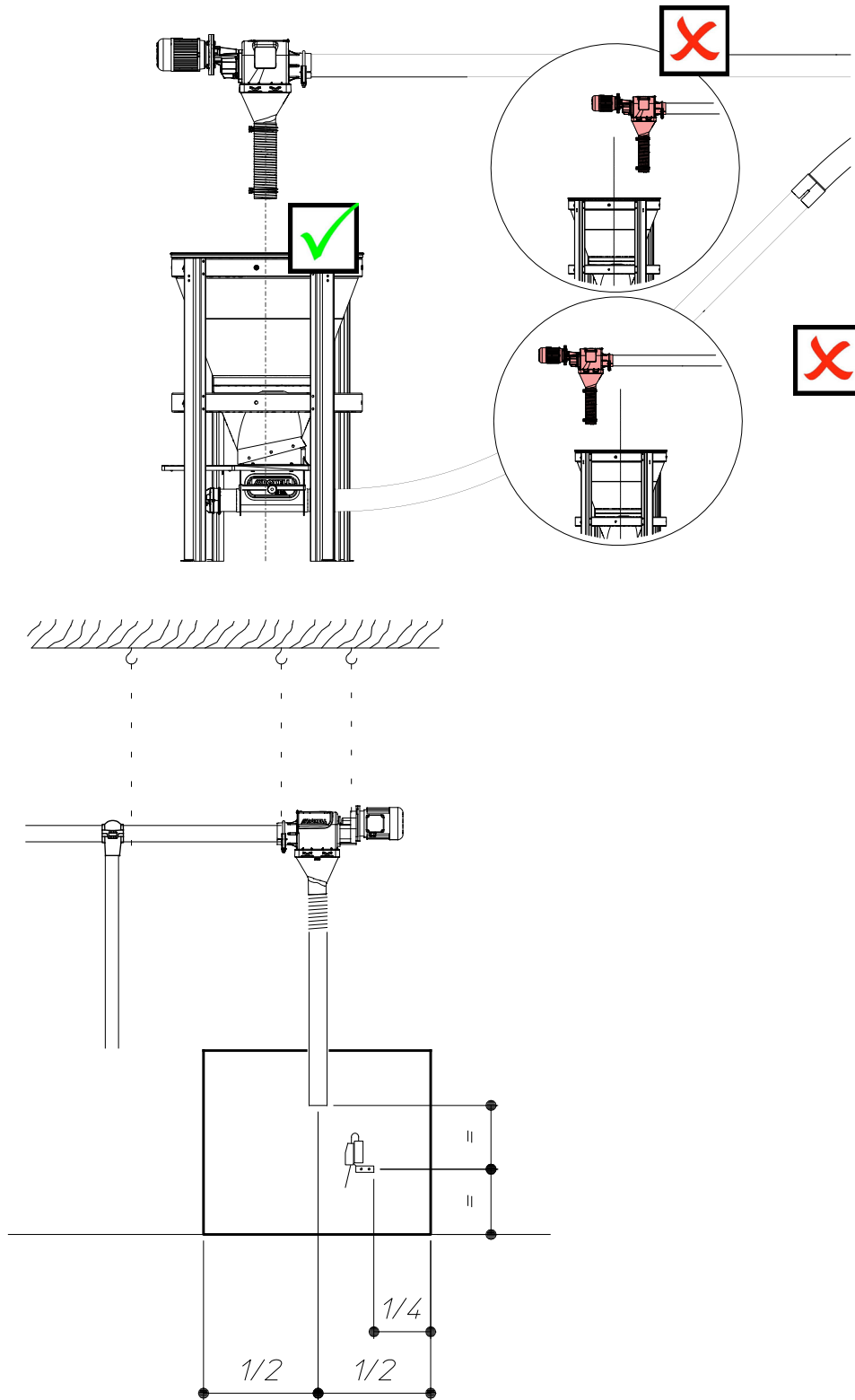

- Install the level switch at the right spot.
- Respect distances.

Level switches

To install the hopper level switch

In a feed trough

See [To install the control unit drop tube](#).

In a Roxell 100 kg hopper

Mount the level switch so that no feed can get behind the flap. The position depends on the drop tube.

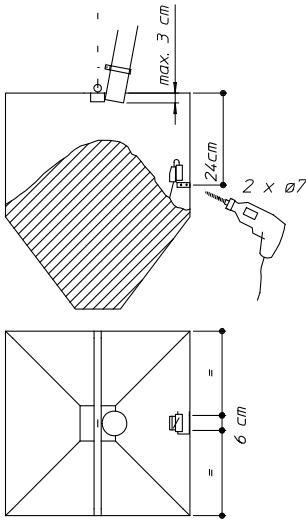

To install the drop tube level switch

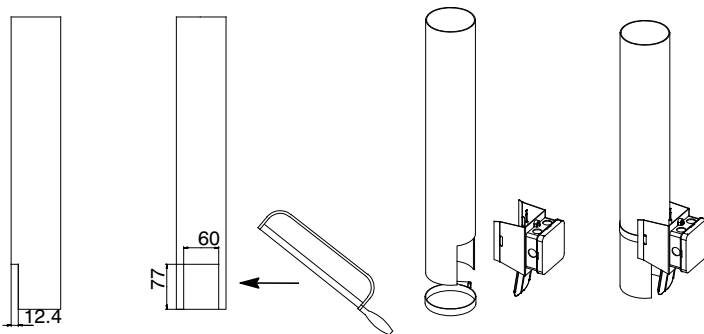

Mount the level switch so that it cannot be activated by:

- The feed flow
- Its own weight

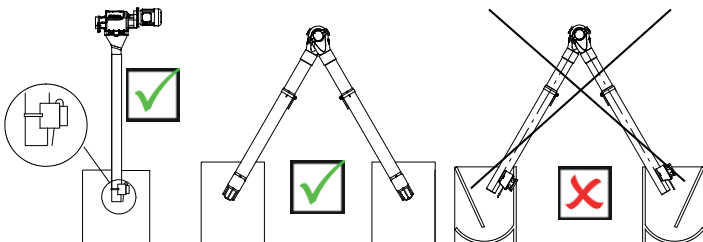

ATTENTION: The bottom of the level switch should be in line with the drop tube end.

To install the drop tube level switch in a line with extension boot

ATTENTION: Provide 100 % feed drop from the outlet just before the extension boot.

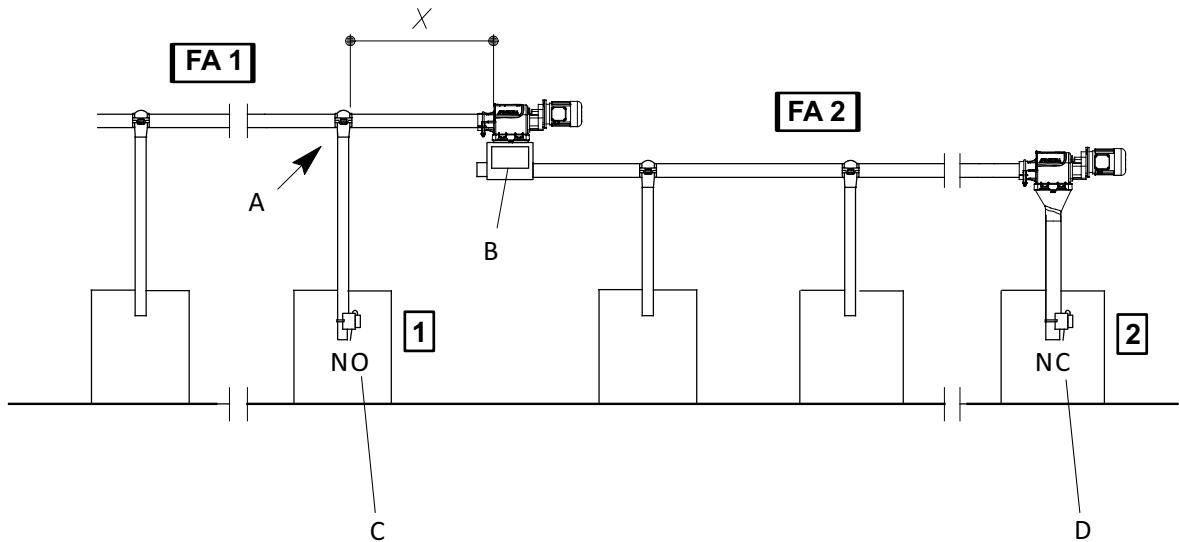

Reference	Description
A	100 % feed drop
B	Extension boot
C	Time delay in minimum position
D	Time delay in maximum position

Purpose

Obtain an empty part "X" at every start.

Process

1. Flex-Auger 1 starts and runs until level switch 2 (NC) is activated.
2. Flex-Auger 2 always starts as FA 1 runs, but runs only during a preset period "T". This period is programmed on a time relay in the control panel.

Table 1: Example

X	T
1 m	Approx. 5 s
2 m	Approx. 10 s

3. Flex-Auger 2 always starts when level switch 1 (NO) is activated.

Time delay



ATTENTION:

- Standard for 03100872 (drop tube level switch)
- Optional for 03100864 (hopper level switch)

To install the delay block

- Connect the delay block (= delay ON) in series with the level switch you want to activate.
- You can connect to the level switch box or to the control panel.
- Always set the time delay on maximum if the level switch is used in a feed trough or 100 kg hopper.
- Always set the time delay on minimum if the level switch is used as intermediate switch in the extension boot.

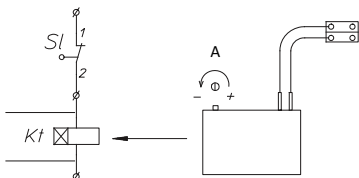

Adjustable with the adjusting button (A) from 1 to 100 s. (Adjusted on 100 s when supplied.)

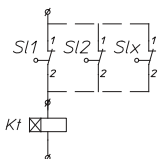

One delay block operates several level switches in parallel.

Sensors

To install the sensor on a drop tube



ATTENTION:

- Install the sensor as high as possible.
- Do not install the sensor in the feed flow, to avoid that the housing wears out.

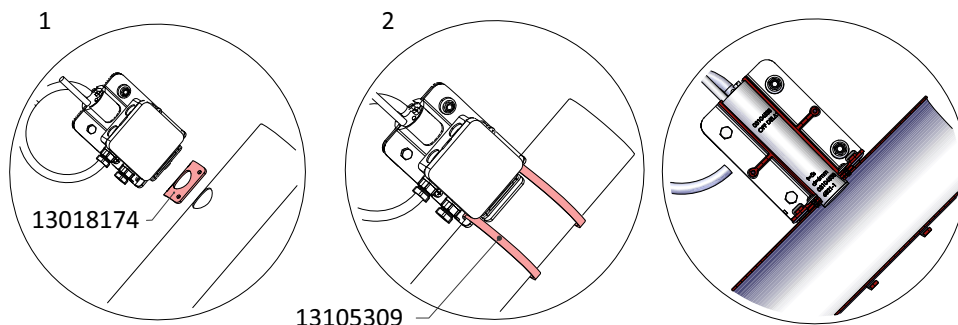

1. Drill a $\varnothing 32$ hole.
2. Fix the sensor holder with two clamps.

24 V DC sensors		
Key	Name	Specifications
03104538	Sensor VC12RTM	D = 6 mm, T = 5 s
03104586		D = 3 mm, T = 1 s
03104578		D = 3 mm, T = 30 s
<p>Connection RTM 24 V DC</p> <div style="display: flex; justify-content: space-between;"> <div style="width: 45%;"> <p>Status LED</p> </div> <div style="width: 45%;"> </div> </div>		

230 V AC sensors		
Key	Name	Specifications
03101185	Sensor VC12RT	D = 6 mm, T = 5 s
03103678		D = 3 mm, T = 1 s
03103660		D = 3 mm, T = 30 s
<p>Connection RTM 230 V AC</p> <div style="display: flex; justify-content: space-between;"> <div style="width: 45%;"> <p>Status LED</p> </div> <div style="width: 45%;"> </div> </div>		

Reference	Description
A	Adjustment screws
B	Lamp
C	Cable
D	Delay: 1 s – 10 min.
E	Distance: 4 – 12 mm
F	Protection screws
G	Remove the protection screw before adjustment.

To install the sensor on a flat surface

1.

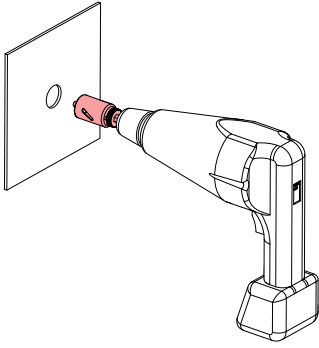
Drill a $\varnothing 48$ mm hole.

2.

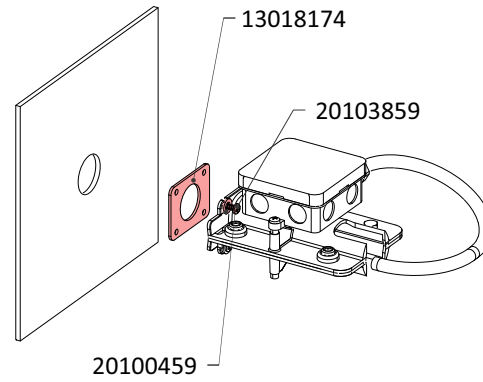

3.

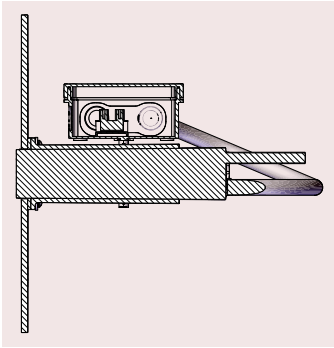

Subtypes Flex-Auger system

Overhead system

General view overhead system

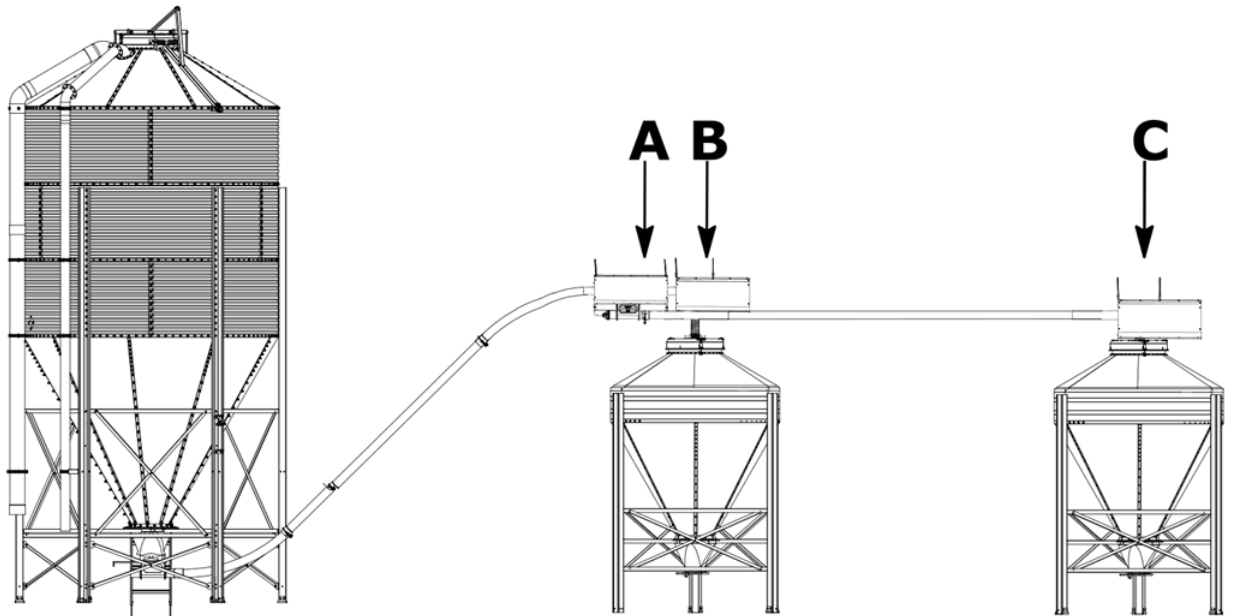

To assemble the overhead system

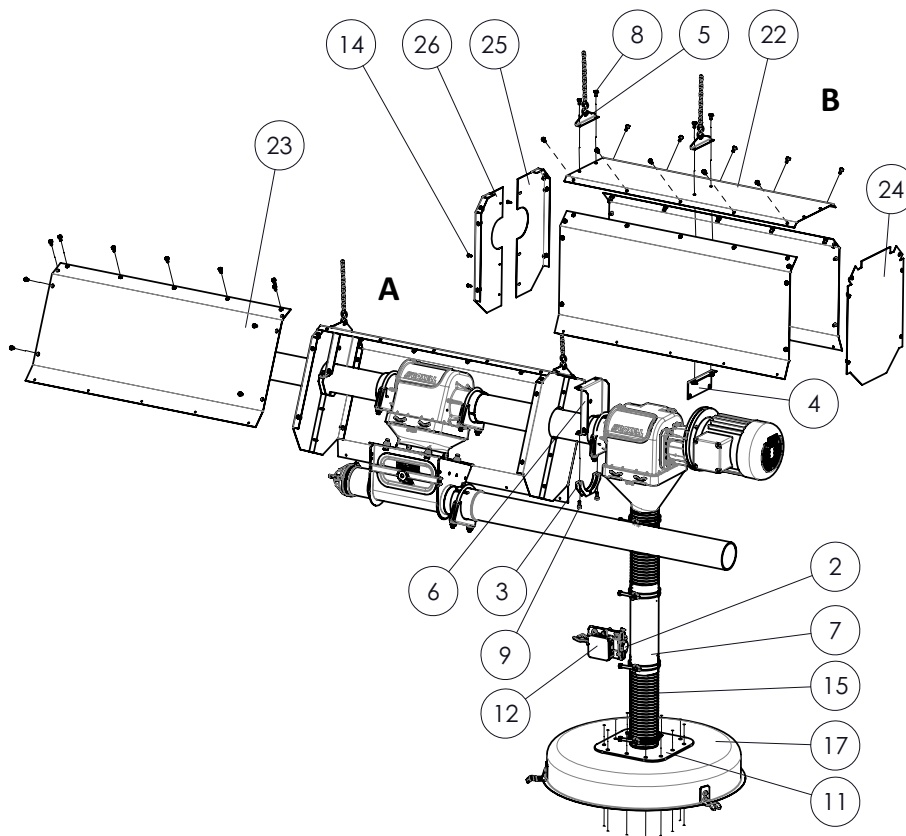

Key	Part Nr.	Part Nr.	Qt.
	FA90	FA125	
2	03101185	03101185	1
3	14900906	13703196	3
4	13000641	13000641	1
5	13000666	13000666	4
6	13008115	13703060	3
8	20100160	20100160	52
9	20101812	20101812	6
11	03000874	03000874	1
12	03103074	03103074	1
14	20100525	20100525	12
15	03100633	03100633	2
17	15902521	15902521	1
22	03000902	03000902	2
23	03000904	03000904	4
24	03000892	03000892	1
25	03000894	03701204	3
26	03000896	03701220	3

A

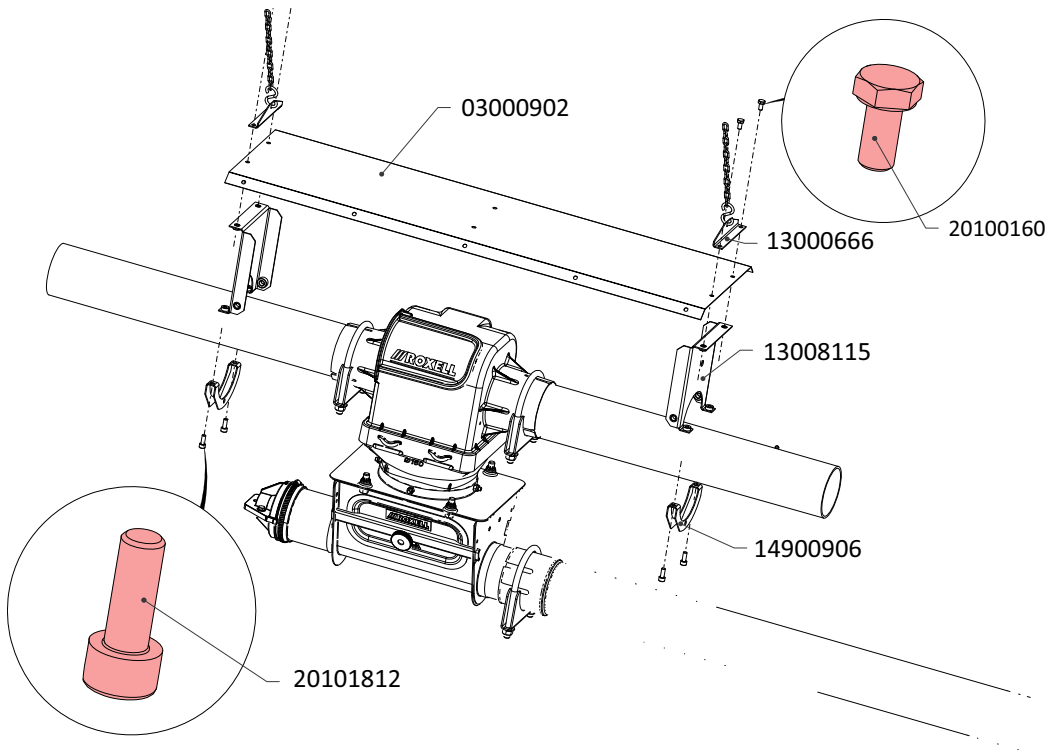

A

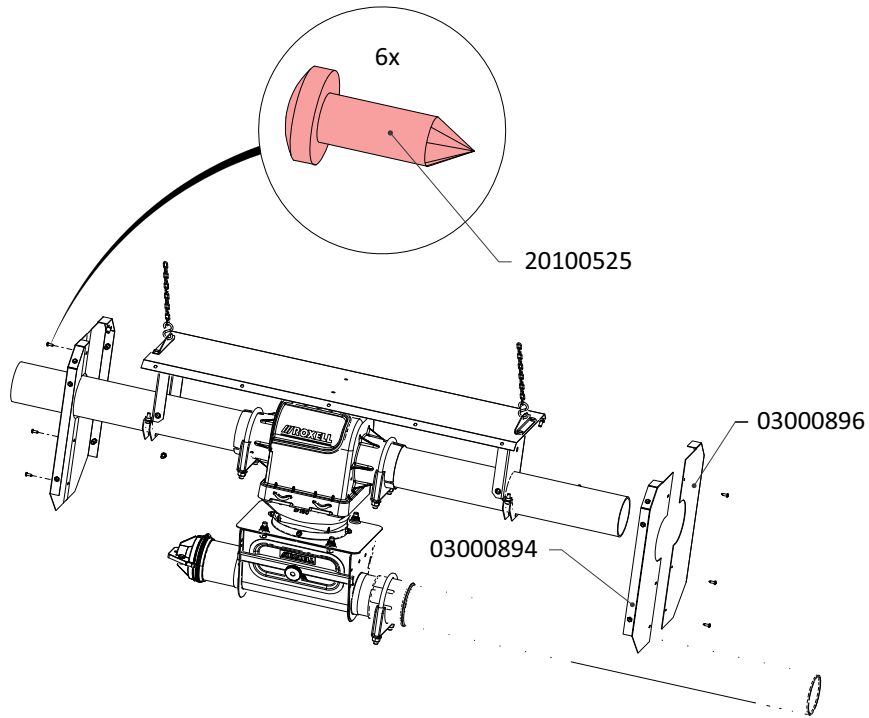

B

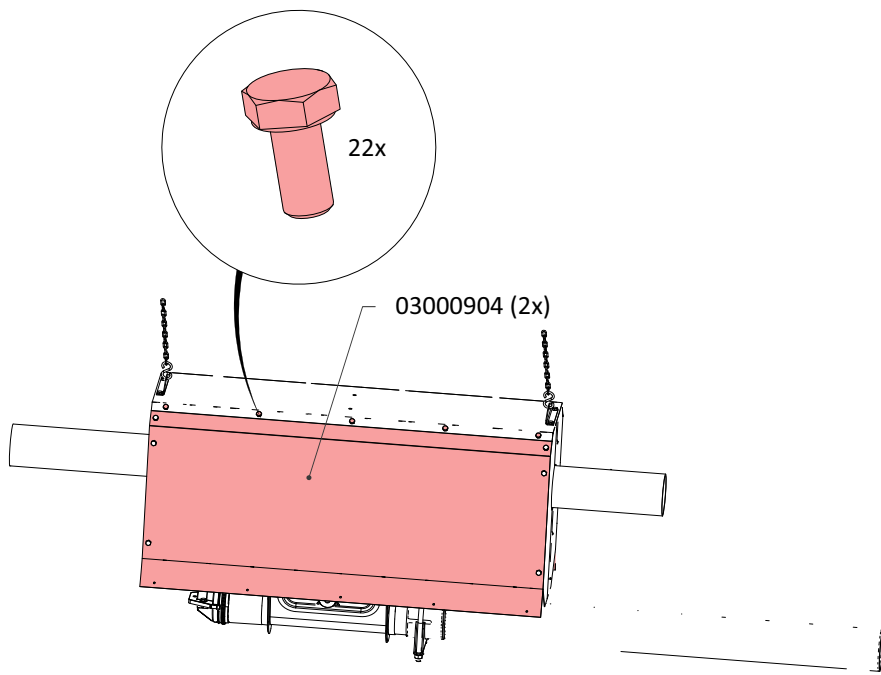

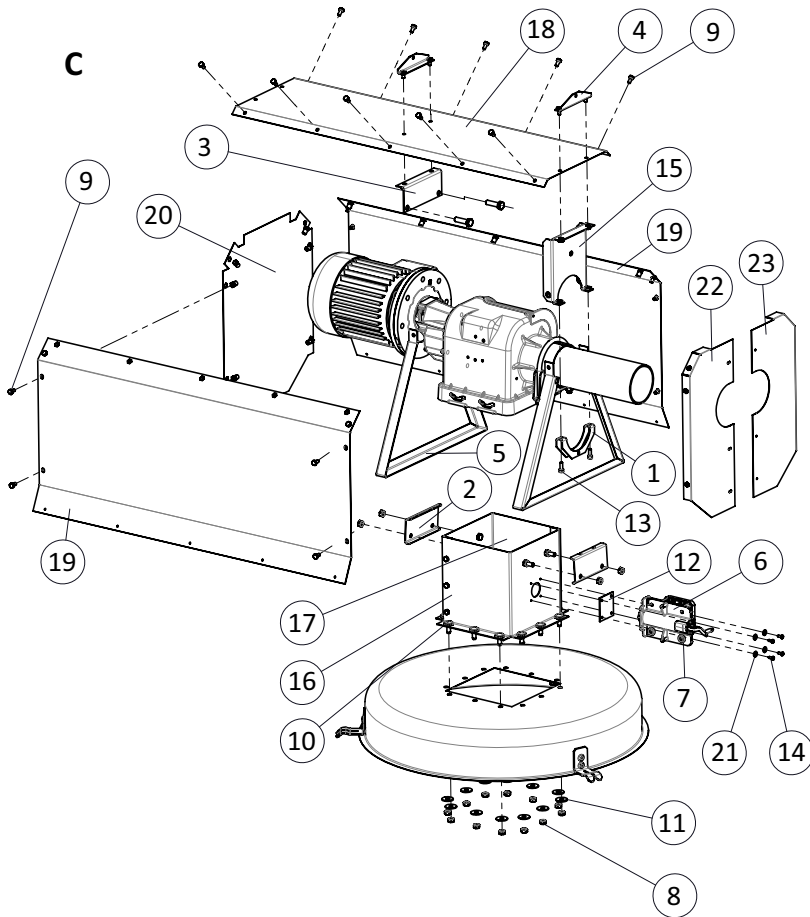

Key	Part Nr.	Part Nr.	Qt.
	FA90	FA125	
1	14900906	13703196	1
2	13203906	13203906	2
3	13000641	13000641	1
4	13000666	13000666	2
5	13000732	13000732	2
6	03103074	03103074	1
7	03103660	03103660	1
8	20200028	20200028	20
9	20100160	20100160	32
10	16103152	16103152	12
11	20102794	20102794	12
12	13000708	13000708	1
13	20101812	20101812	2
14	20100525	20100525	4
15	13008115	13703060	1
16	13000682	13000682	1
17	13000674	13000674	1
18	03000902	03000902	1
19	03000904	03000904	2
20	03000892	03000892	1
21	20100459	20100459	4
22	03000894	03701204	1
23	03000896	03701220	1

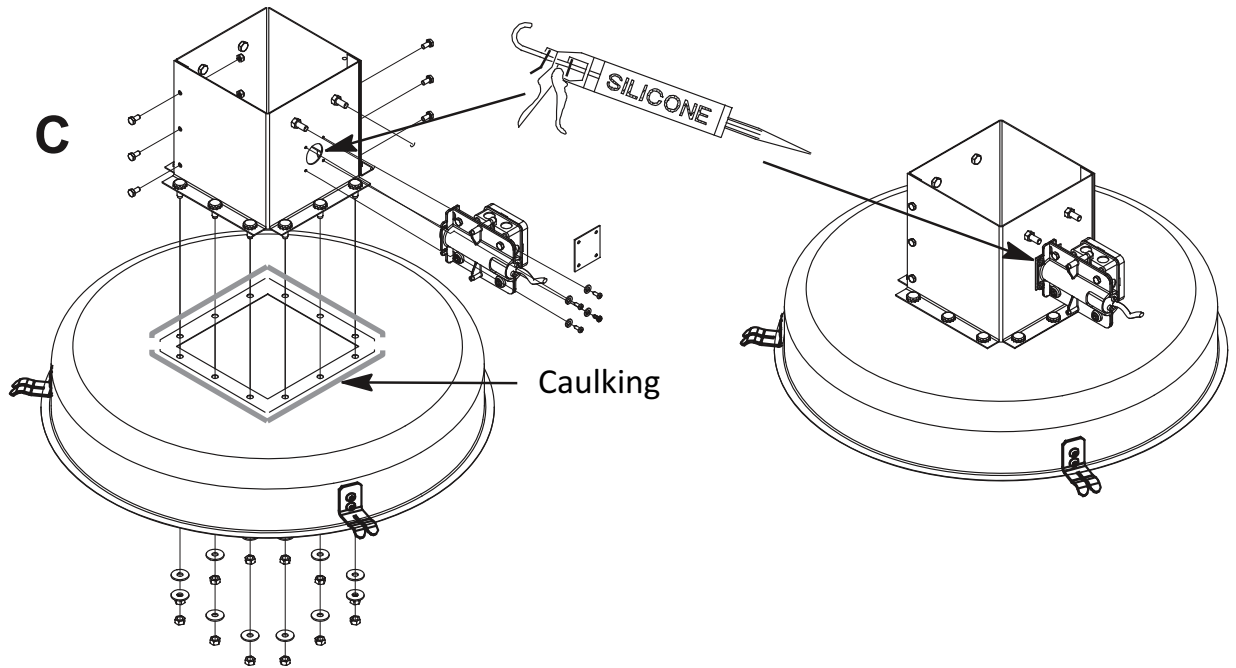

IMPORTANT: First install the Flex-Auger!

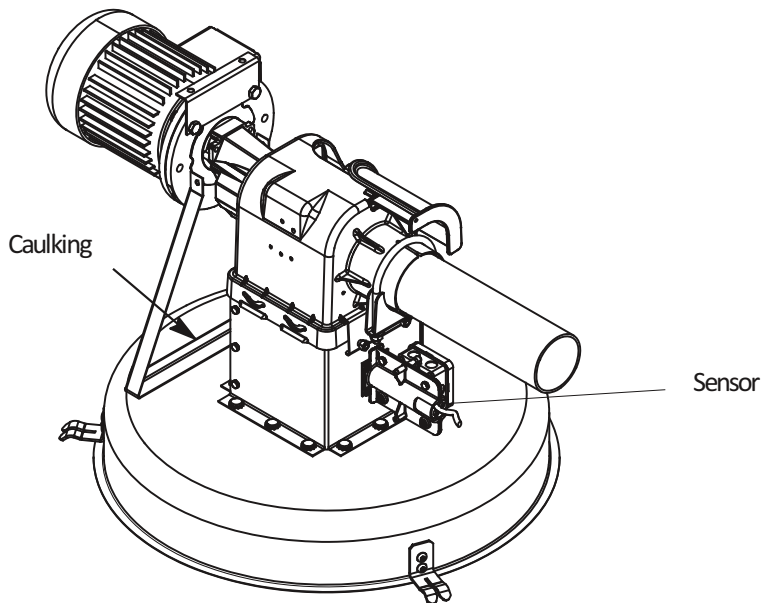

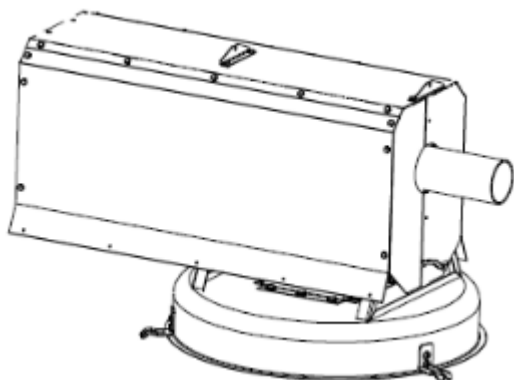
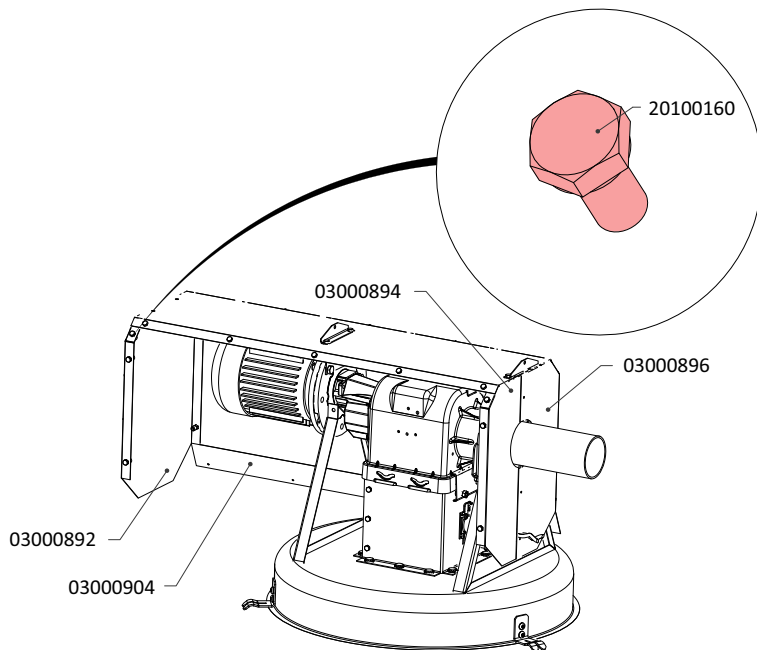
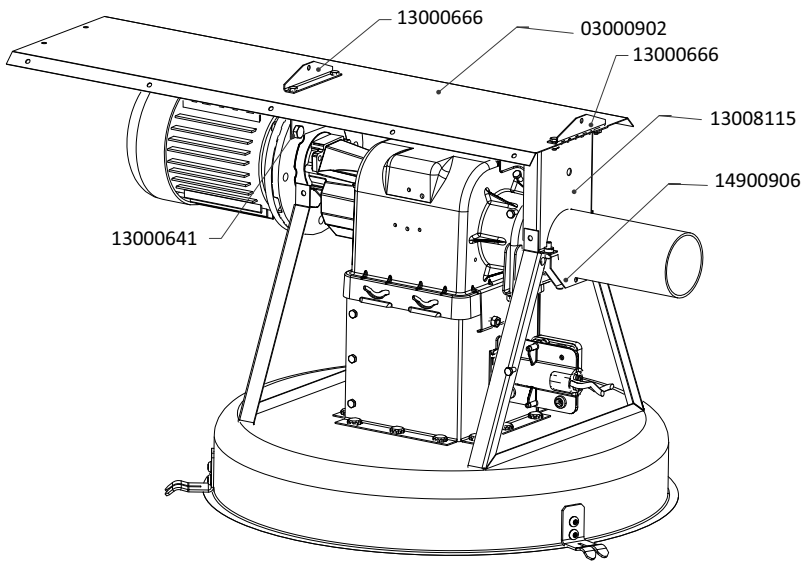

CDS system

To install the Flex-Auger™ from hopper to house

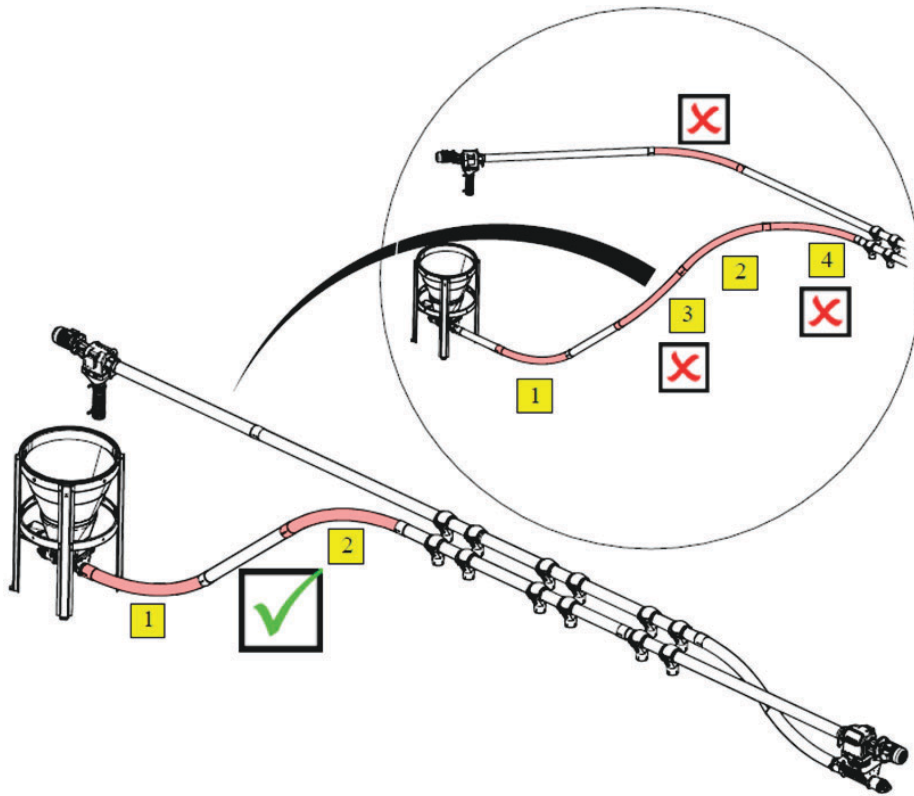

To install the return Flex-Auger™ from house to hopper

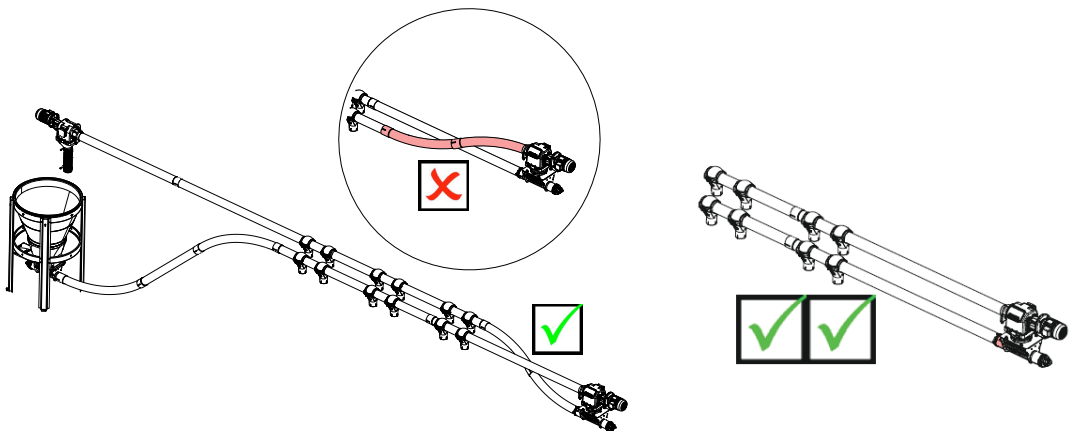

Location of the outlets - CDS - standard

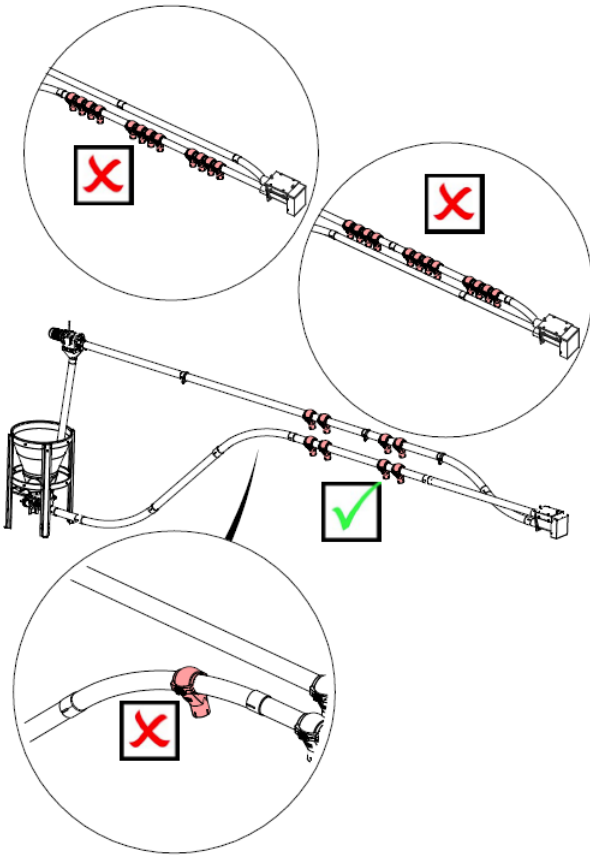

Location of the outlets - CDS - broiler cage

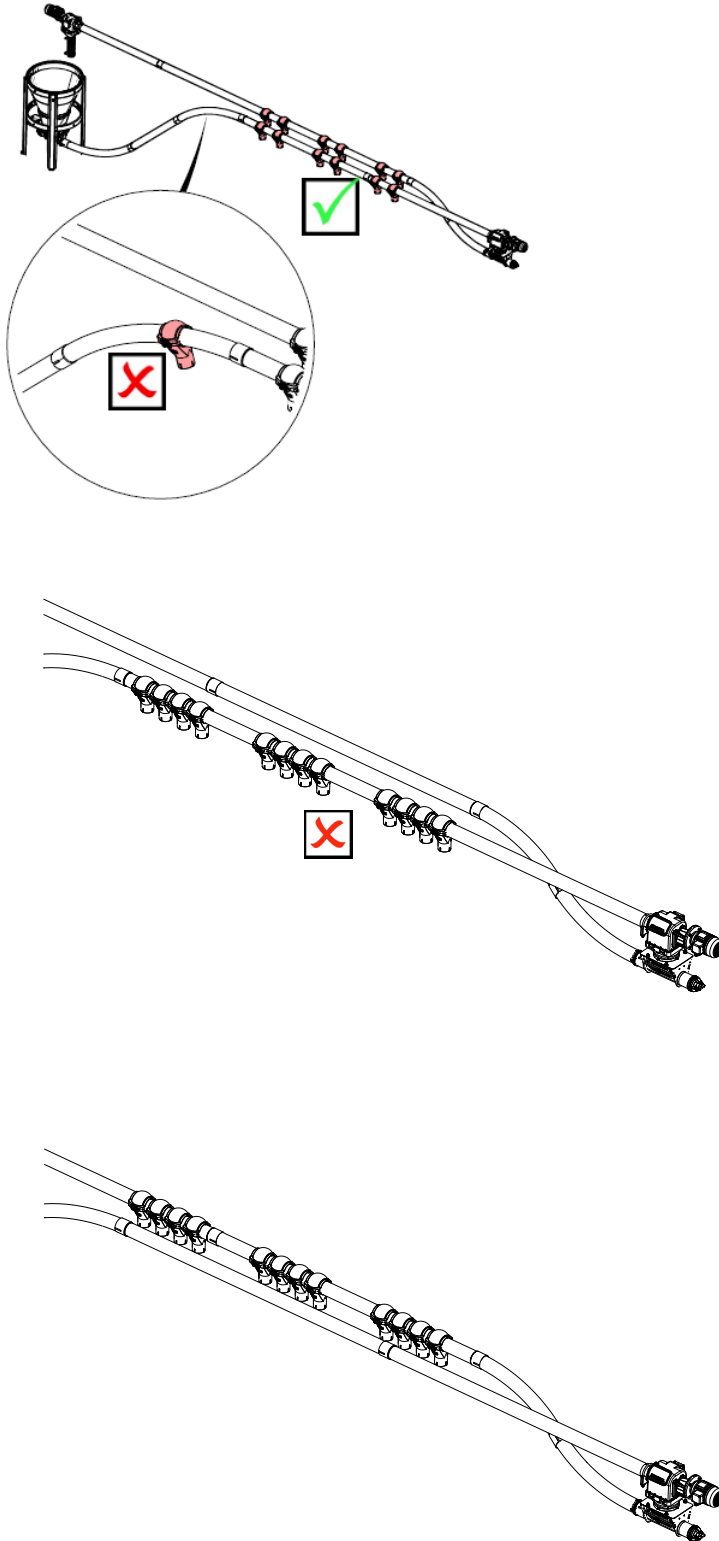

Tandem system

To install the return tandem system

- Determine the distances between both bins

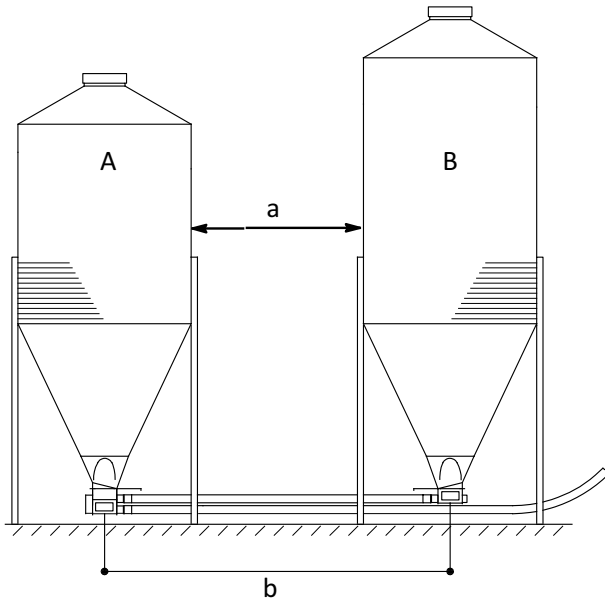

a	Minimum distance
b	Maximum centre distance between both bins: 4 m

i NOTE: If the bins do not have the same capacity, make sure that bin A is the smallest.

- Install the transfer assemblies

Install the slides of the transfer assemblies as shown on the drawing.

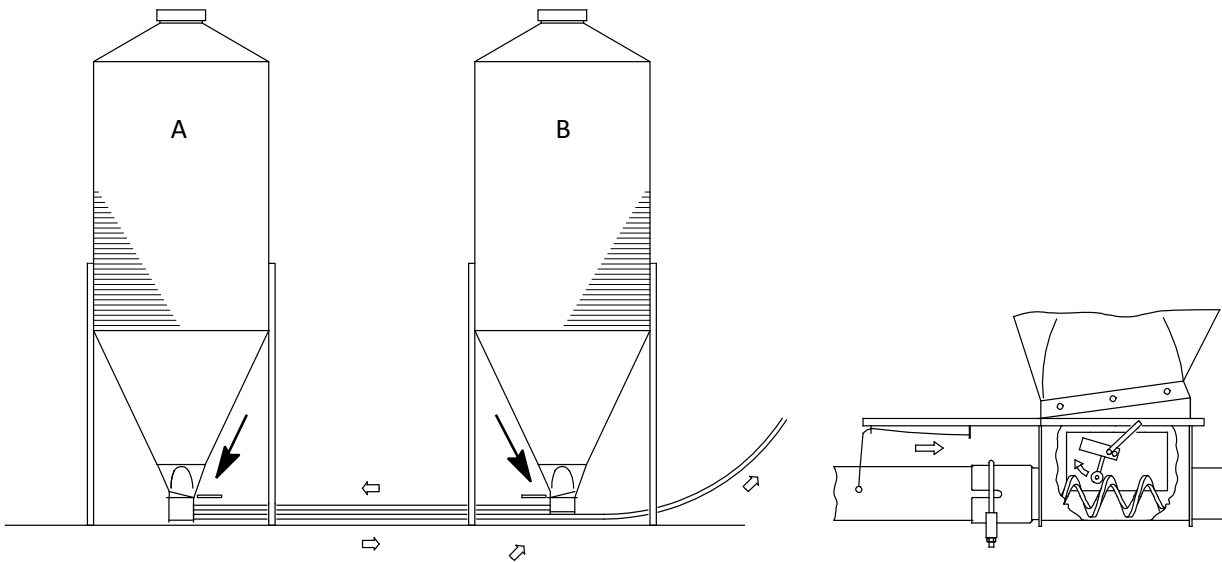

i NOTE: Only applicable for model 125: If you don't use bin B (or it is empty) and you close the slide, the thumper in the tandem intake boot is pushed away from the auger.

• **Determine the tube length between both bins**

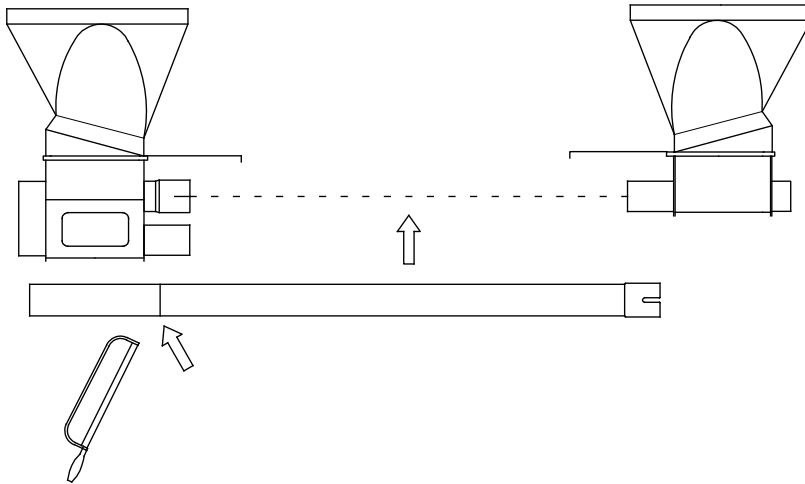

ATTENTION:

- Do not fix the intake boot to the upper boot at this stage.
- Fix the tube to the intake boot.
- **To install the flow regulator**

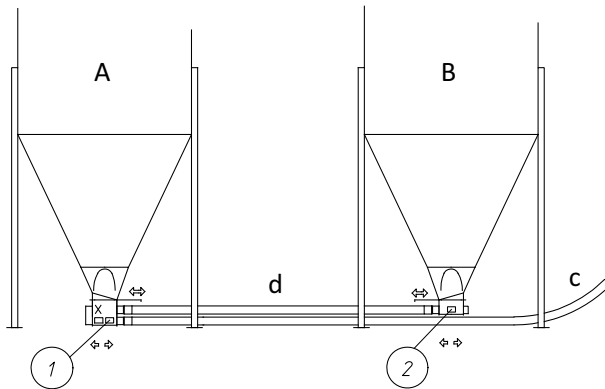

Position X = highest capacity.

- 1 Close the slide of bin B.
- 2 Open the slide of bin A with the tandem intake boot.
- 3 Adjust flow regulator 1 in the intake boot until the system runs without overload and/or until you obtain the required capacity.
- 4 Close the slide of bin A.
- 5 Open the slide of bin B.
- 6 Adjust flow regulator 2 so that the feed flow from B to A is slightly lower than the Flex-Auger system feed flow. That way no obstruction will occur.



ATTENTION: Make sure that all tube connections are watertight. Firmly tighten the tube clamps (minimum 10 Nm).

- 7 Install auger c from bin A to the control unit.
- 8 Install auger d under slight tension: 5 to 6 cm between the two bins.

To install the tandem in line (model 75 and 90)

Install the slides of the transfer assemblies as shown on the drawing.

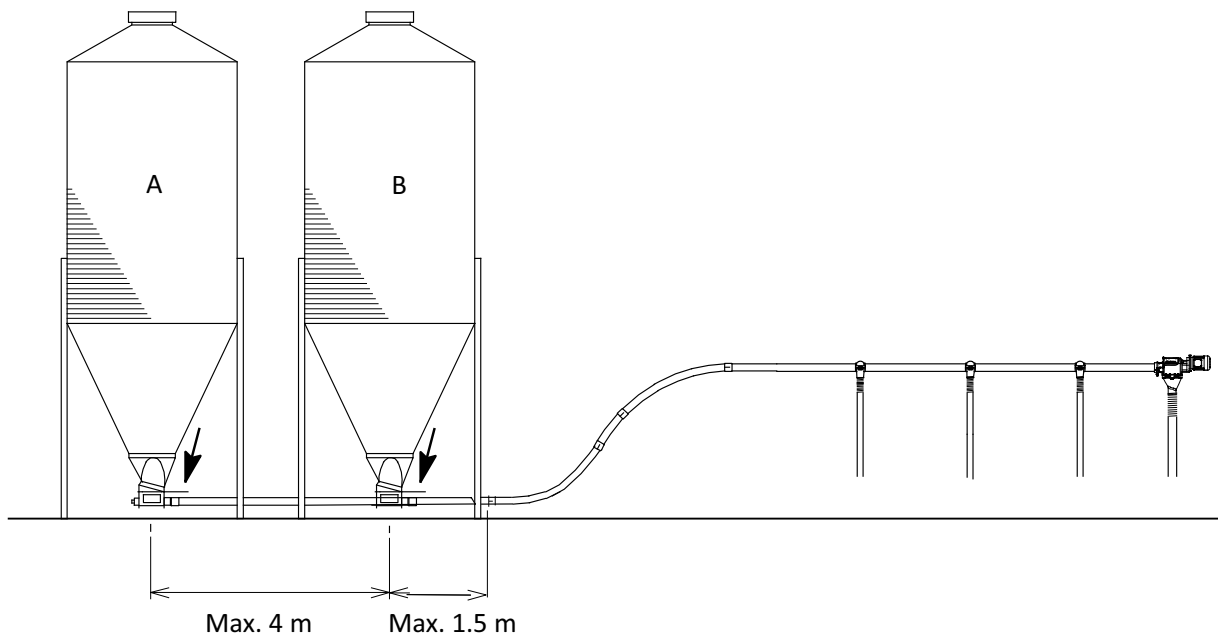

- This tandem is a straight-through Flex-Auger.
- Install the exact tube length between both bins (see [Determine the tube length between both bins](#)).
- Total max. length: see [Graphs with maximum lengths](#).
- Install the valves in the direction as shown on the drawing.

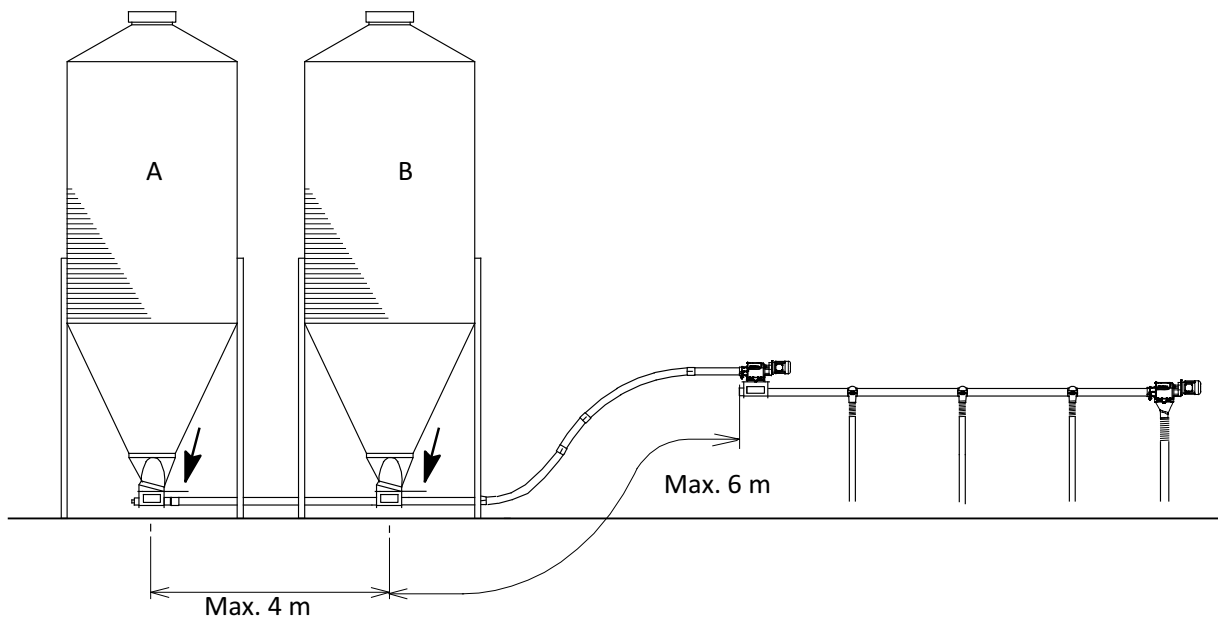
To install the tandem in line (model 125)

- This tandem is a straight-through Flex-Auger.
- Install the exact tube length between both bins (see [Determine the tube length between both bins](#)).
- Install a control unit or extension boot not further than 10 m away from bin A.
- Install the valves in the direction as shown on the drawing.

To reduce the capacity

Mount a tube in the auger between the two bins to avoid that the auger blocks.

Table 2: Tube measurements

Tandem In line	
Model 75	Install a tube $\varnothing 32$ mm (03103066) to the anchor of feed bin A.
Model 90	Install a poultry tube $\varnothing 44.5$ mm without holes (00102269) to the anchor of feed bin A.
Model 125	Install a tube $\varnothing 60$ mm (03700861) to the anchor of feed bin A.

The tube must extend approx. 20 mm from the boot of feed bin B.

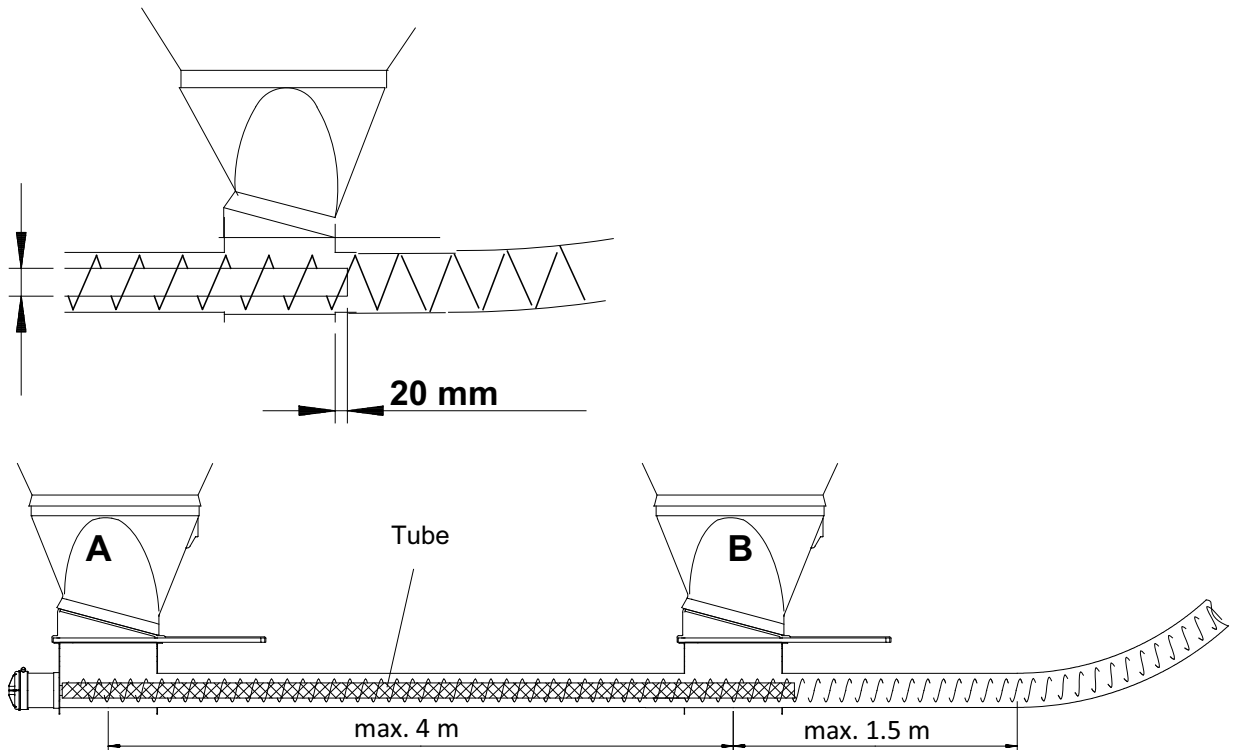

• **Installation of the tube**

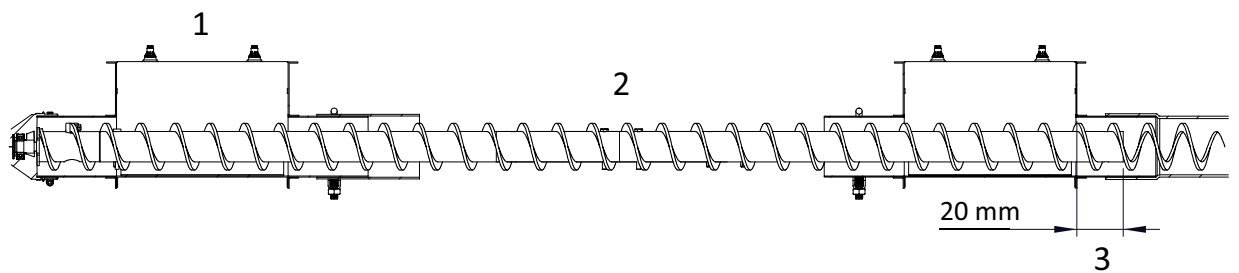

1. Mount the tube in the intake boot.
2. Connect the tubes if the length is more than 3 m.
3. Let the tube extend approx. 20 mm from the second intake boot.

Table 3: Model 75 and 90

Step	Drawing	Details
1.	 <p>Bolt M6</p>	<p>Tube:</p> <ul style="list-style-type: none"> • FA 75: Ø32 (03103066) • FA 90: Ø44.5 (00102269)
2.	<p>Fig. 12: FA 75</p>  <p>Bolt M6</p> <p>Fig. 13: FA 90</p> 	<p>Connection piece:</p> <ul style="list-style-type: none"> • FA 75: Ø28.7 x 80 (13109812) • FA 90: Ø41.5 x 80 (13204116)
3.	<p>Fig. 14: FA 75</p>  <p>Bolt M6</p> <p>Fig. 15: FA 90</p> 	<p>Tube end:</p> <ul style="list-style-type: none"> • FA 75: Guide piece (13109160) • FA 90: No extra's

Table 4: Drill holes

Tube and connection piece	 <p>25 25 ø 6.5 (2x)</p>
Tube end	 <p>ø 6.5 10</p>

Table 5: Model 125

Step	Drawing	Details
1.		Tube: Ø60 (03700861)
2.		Connection piece: Ø65 x 2 x 80 (13701644)
3.		Tube end: Ø65 x 2 x 80 (13701263)

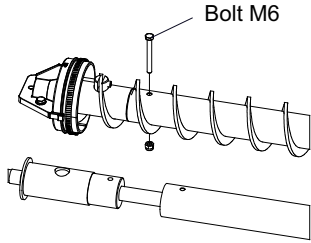
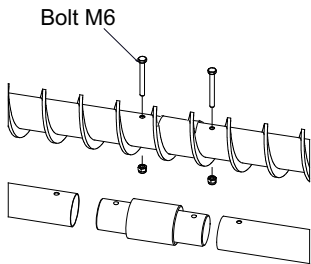
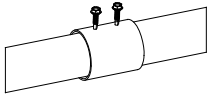
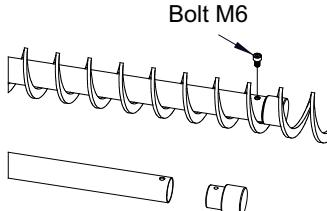
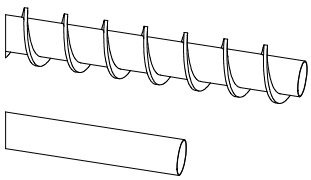
• **Auger stretching (tandem in line)**

- 1 Do not yet connect the auger in the intake boot A (leave approx. 20 cm outside the boot).
- 2 Open the feed bin valve A and start the Flex-Auger.
- 3 Let the auger run until the feed comes out at the control unit.
- 4 Stop the Flex-Auger and mark the auger (M1).
- 5 Close the feed bin valve A and let the Flex-Auger run empty.
- 6 Open the feed bin valve B and start the Flex-Auger again.
- 7 Let the auger run until the feed comes out at the control unit.
- 8 Stop the Flex-Auger and mark the auger (M2).
- 9 Cut the auger in the middle between M1 and M2 and connect them in the intake boot with the anchor and bearing assembly.

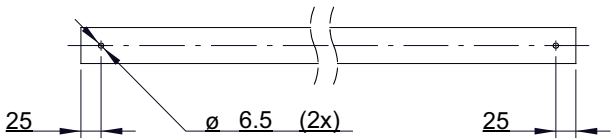
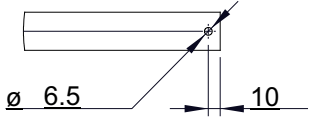
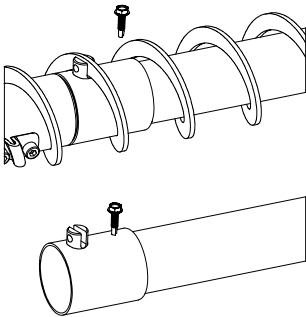
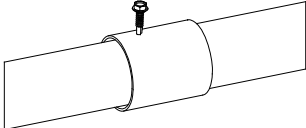
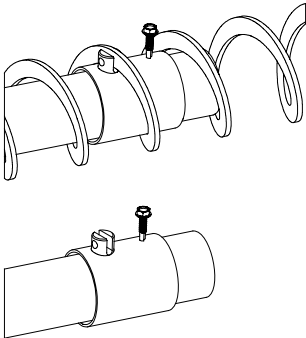
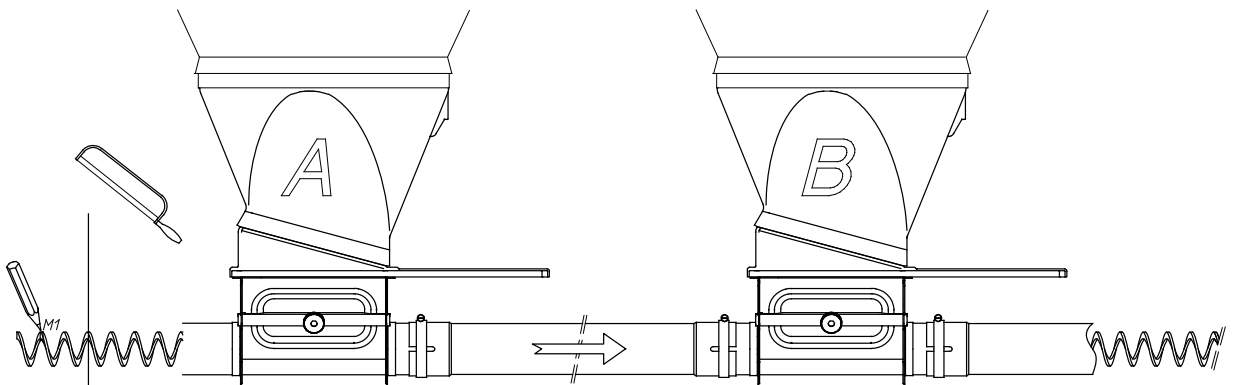

Flex-Auger Mix system

To install the Flex-Auger Mix system

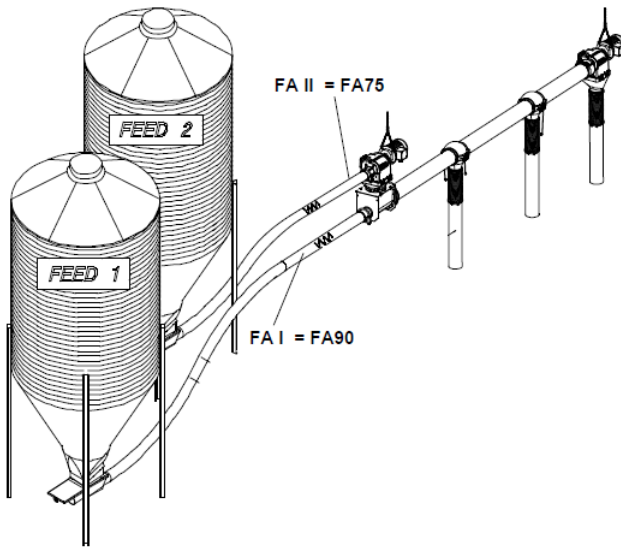

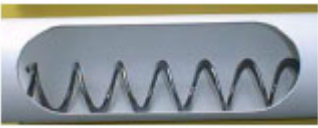
Drawing	Tube	Auger
	Model 90	Model 90
	Model 125	Model 90

• Installation of Flex-Auger I

See general installation instructions Flex-Auger 90/125.

Flex-Auger I = auger model 90 from bin to control unit. No auger model 125 needed.

ATTENTION: Special remarks:

- Always install the Flex-Auger Mix intake boot horizontally, never under an angle.

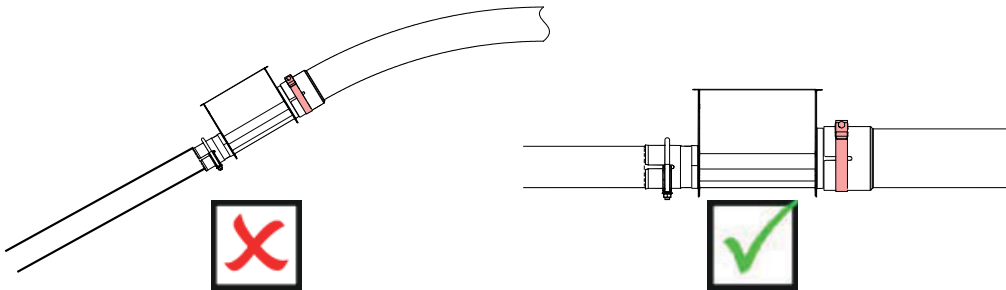

- Always mount 1 manual outlet model 125 with shut-off just after the mixing point. This is needed for calibration. This outlet must have a 100% drop out.

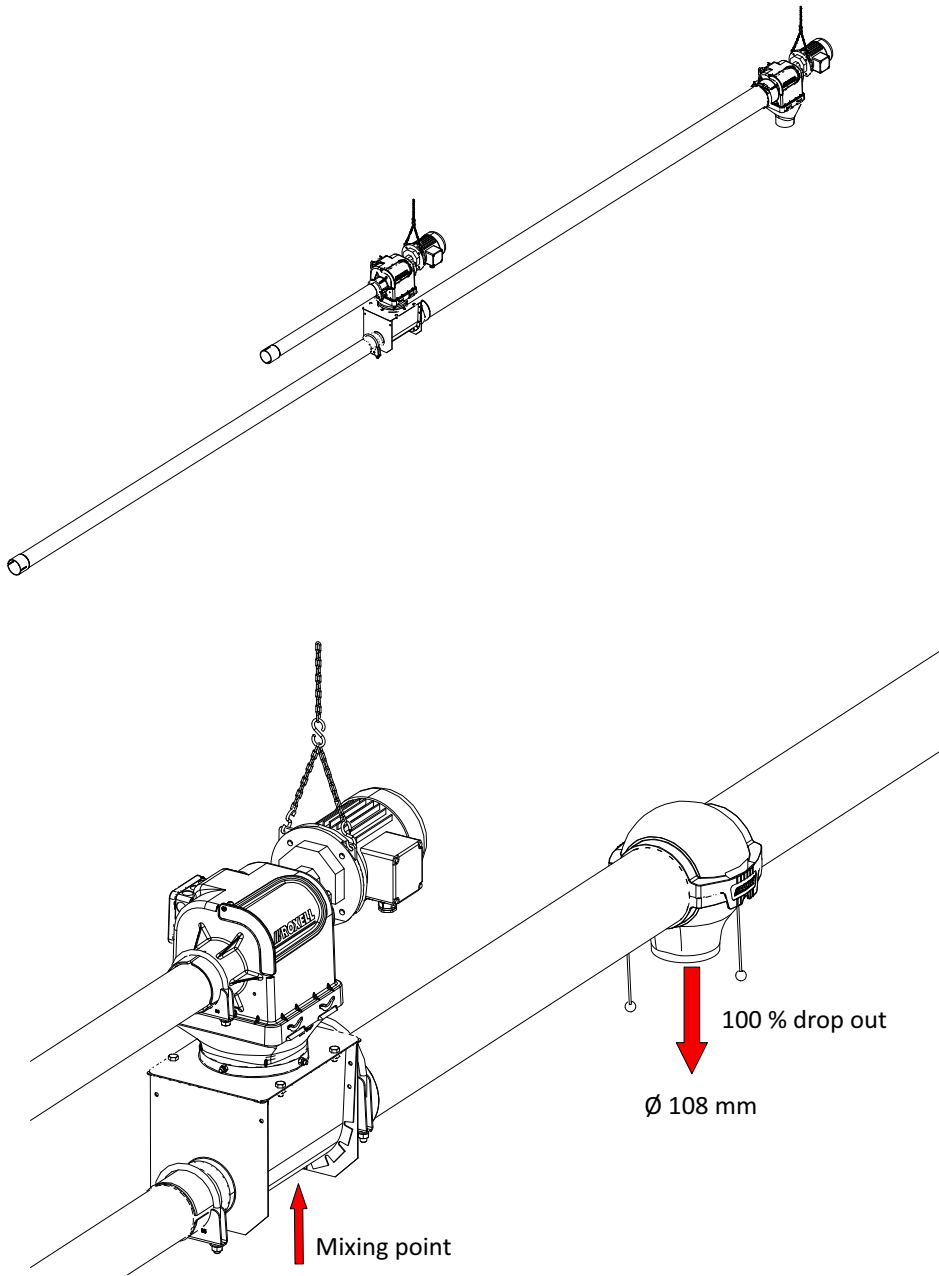

• **Installation of Flex-Auger II**

See general installation instructions Flex-Auger 75.



ATTENTION: Special remarks:

- Maximum inclination of FA II: 30°

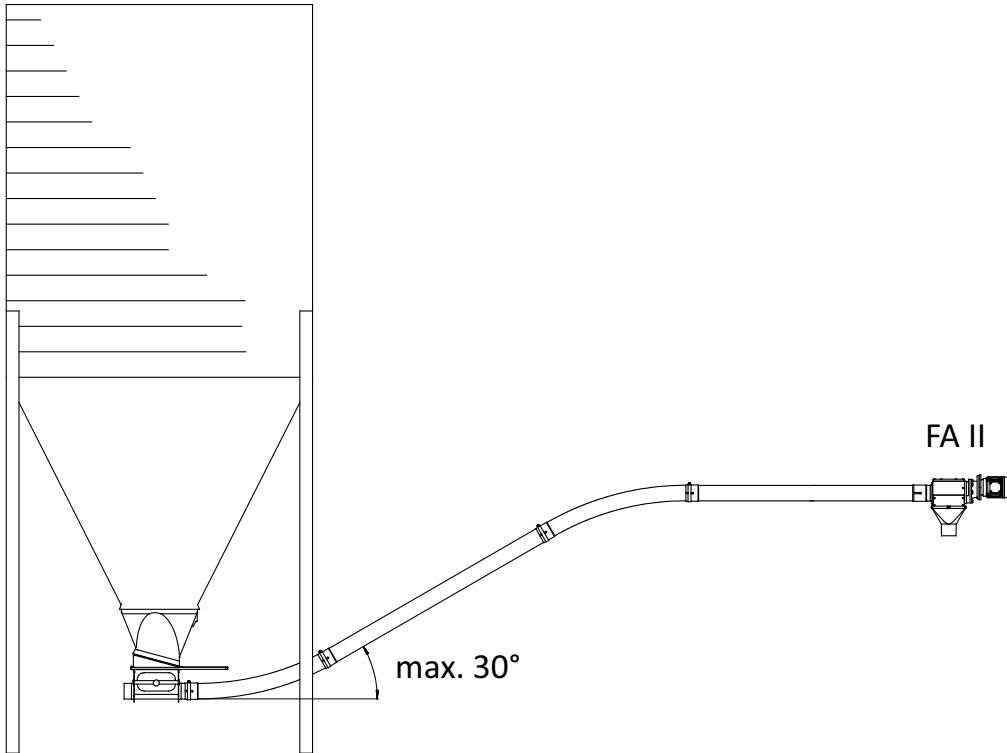

- Intake boot: Always set the flow regulator on minimum feed flow = **FLOW REGULATOR CLOSED**

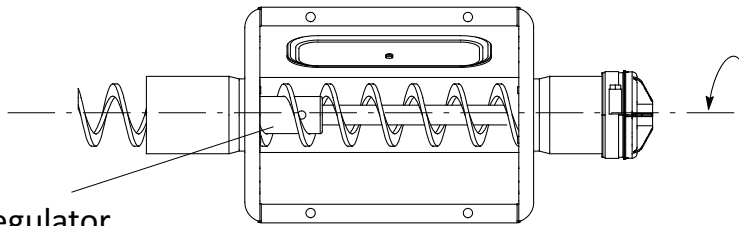

- Power unit: Only **one** power unit type!
- The motor is **standard in triangle**. Do **not** change this.

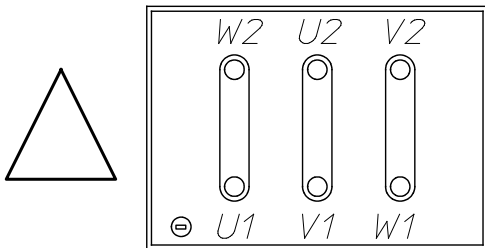

To calibrate the Flex-Auger Mix system

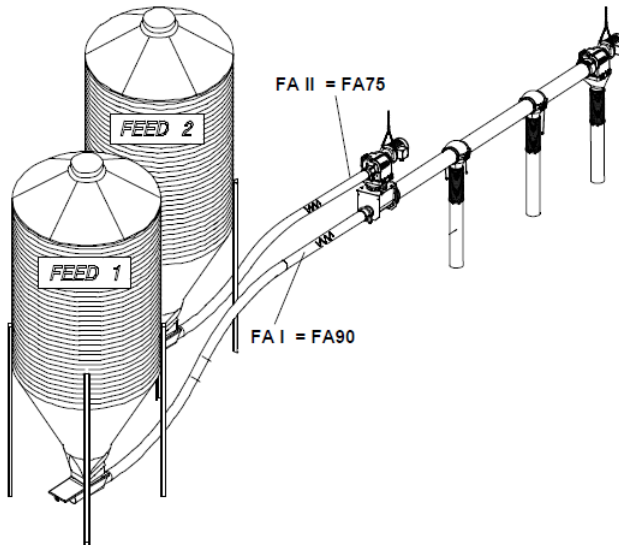

Make sure that all Flex-Augers are ready for use:

- Let the Flex-Augers run during a few minutes.
- The tubes must be completely filled.
- The slide of the transfer assembly must be completely open.

• Capacity of Flex-Auger I

- 1 Open the outlet just after the mixing point.
- 2 Put a sack or a wheelbarrow under the drop tube of that outlet.



- 3 Put the Flex-Auger switch on position I.
- 4 Let Flex-Auger I run during 20 s.
- 5 Weigh the feed in the sack or the wheelbarrow (= "X" kg).

Capacity of Flex-Auger I = "X" kg x 180 = ... kg/h.

TIP: Repeat the two preceding steps to check your first measuring.

• Capacity of Flex-Auger II in function of the frequency

- 1 Take the grey drop of Flex-Auger II out of the Flex-Auger Mix intake boot.
- 2 Use a drop tube to let the feed flow into a sack or wheelbarrow.



- 3 Put the frequency switch on position 2 (= 20 Hz).



- 4 Put the Flex-Auger switch on position II.
- 5 Let Flex-Auger II run during 20 s.
- 6 Weigh the feed in the sack or the wheelbarrow (= "Xa" kg).

Capacity of Flex-Auger II with frequency 20 Hz = "Xa" kg x 180 = ... kg/h.



TIP: Repeat the two preceding steps to check your first measuring.

7 Follow the same procedure with the frequency switch on position **4** (40 Hz = "Xb" kg) and **6** (60 Hz = "Xc" kg).

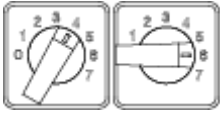

- Capacity of Flex-Auger II with frequency 40 Hz = "Xb" kg x 180 = ... kg/h.
- Capacity of Flex-Auger II with frequency 60 Hz = "Xc" kg x 180 = ... kg/h.

8 Put these three measures in the empty graph you have received together with the control panel.

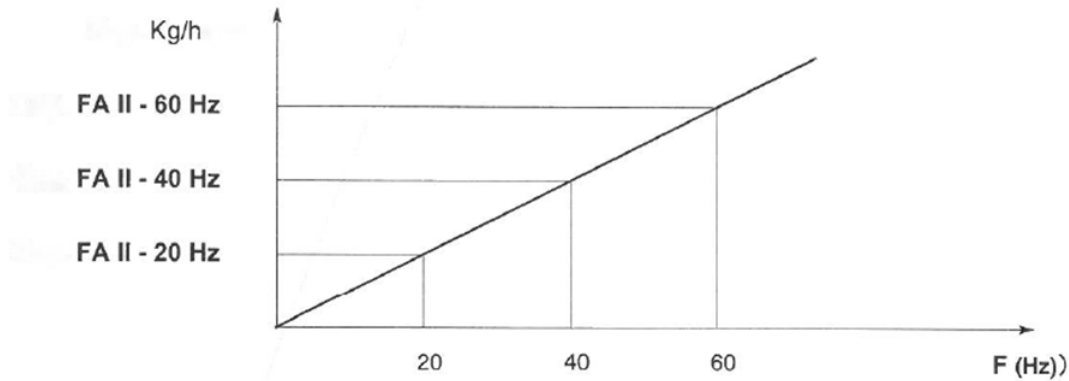

• **Determination of the required percentages/capacities**

Position	Percentage
0	STOP
1	% = Capacity II - P1
2	% = Capacity II - P2
3	% = Capacity II - P3
4	% = Capacity II - P4
5	% = Capacity II - P5
6	% = Capacity II - P6
7	% = Capacity II - P7

Formula:

$$\text{Cap II} = \frac{X(\%) \times \text{Cap I}}{100 - X(\%)}$$

Example:

Position 1 = 5%	Cap II - p1 = $\frac{5 \times 2500}{100 - 5} = 131\text{kg/h}$
Capacity I = 2,500 kg/h	

• **Determination of the correct frequencies**

Use the graph Capacity FA II in function of the frequency.

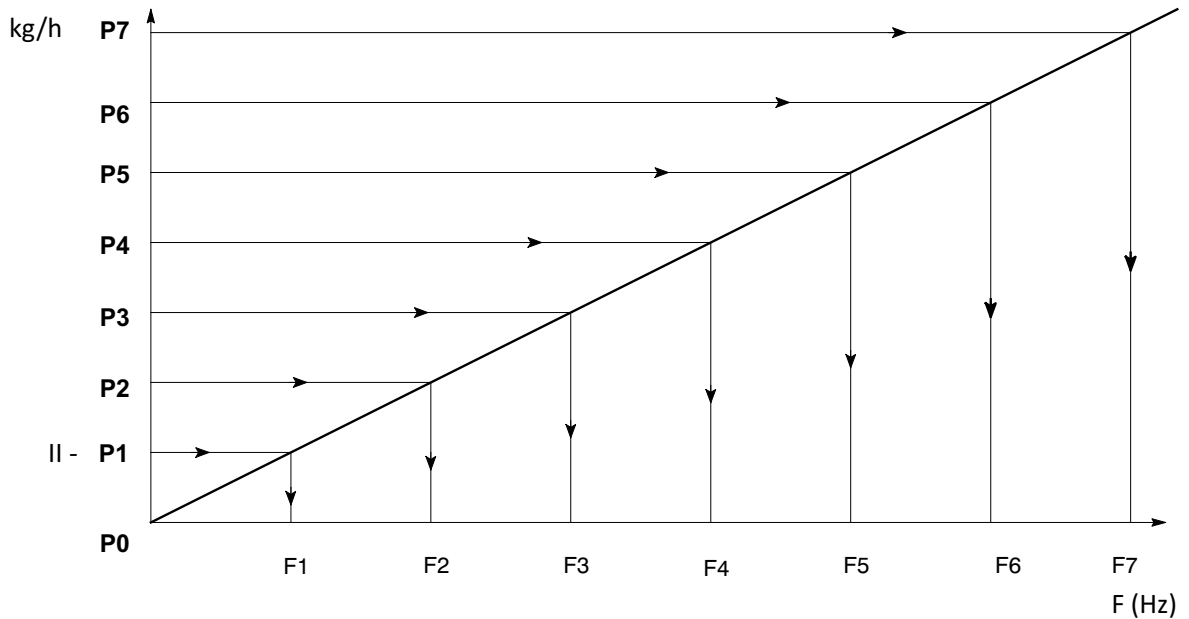

 **NOTE:** min. 10 Hz - max. 130 Hz

• **Programming of the frequency regulator**

You must program the following parameters:



Parameter	Drawing
P1001 = F1	
P1002 = F2	
P1003 = F3	
P1004 = F4	
P1005 = F5	
P1006 = F6	
P1007 = F7	

- 1 Press **P**.
- 2 Go to parameter P1001 with ▲.
- 3 Press **P**.
- 4 Change the value with ▲ and ▼ (value = frequency, for example 12 Hz).
- 5 Press **P** to confirm that value.
- 6 Go to parameter P1002 with ▲. Repeat the steps mentioned above.
- 7 Follow the same procedure for the other parameters P1003, P1004, P1006 and P1007.
- 8 After P1007, go to P000 with ▲.
- 9 Press **P** to quit the program.

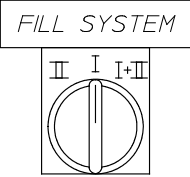
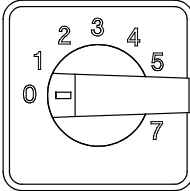
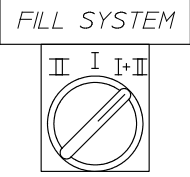
• Activation or deactivation of the Flex-Auger Mix

When you do not want to mix	When you want to mix
	
	

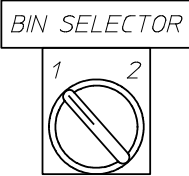
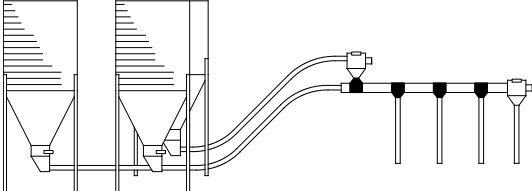
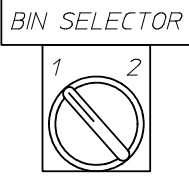
• Bin choice



Bin(s) used	Result
<p>One bin with minimum sensor for feed I</p>	<ul style="list-style-type: none"> • The system stops as soon as the bin is empty. • Put the bin selector always at position 1. 
<p>Two bins with minimum sensor for feed I</p>	<ul style="list-style-type: none"> • The system stops as soon as the bin is empty. • Put the bin selector at position 1 or 2, depending on the bin you use.  
<p>No bins with minimum sensor for feed I.</p>	<p>Turn the bin selector off.</p> <p> ATTENTION: When a bin is empty, the system keeps on running and feed II will be fed for 100%.</p>

Electricity: watch out!



DANGER: Leave connections to the system to a qualified electrician!

- Wire the system with the utmost care and attention.
- Always ensure proper earthing.
- Check all the connections before you turn the system on.
- Always follow the wiring diagrams included in the control panels.
- Compare the settings of the motor protection with the data on the motor label.
- Motor protections are set at minimum by the manufacturer.
- If you do not use a Roxell control panel, ensure that you provide the necessary motor protections.
- Compare the motor label and the motor connection with the local voltage:

	
3 x 380 V + N	IEC38 – 3 x 400 V + N
3 x 415 V + N	
	
3 x 220 V	IEC38 – 3 x 230 V
3 x 240 V	
3 x 200 V	

Maximum cable lengths to the motors: See [Maximum cable lengths to the motors](#).

Electrical symbols

Symbol	Description	Symbol	Description
	Main switch		Automatic fuse
	Thermal-magnetic motor protection with auxiliary contacts		Motor
	Control circuit relay		Contactor
	Time clock		Preset counter
	Signal lamp		Serial timer
	Adjustable timer with mode selection		3-position switch with M/0/A indication plate
	2-position switch with 0/1 indication plate		Push button
Safety switch 	Safety or level switch for Flex-Auger, Discafex,...	Max. sensor in hopper under weigher 	Sensor with NC contact (supply ON)
Control pan 	Control sensor for KiXoo	Min. sensor in hopper under weigher 	Sensor with NO contact (supply ON)

Wiring diagrams

Wiring diagram for 1 x 230 V

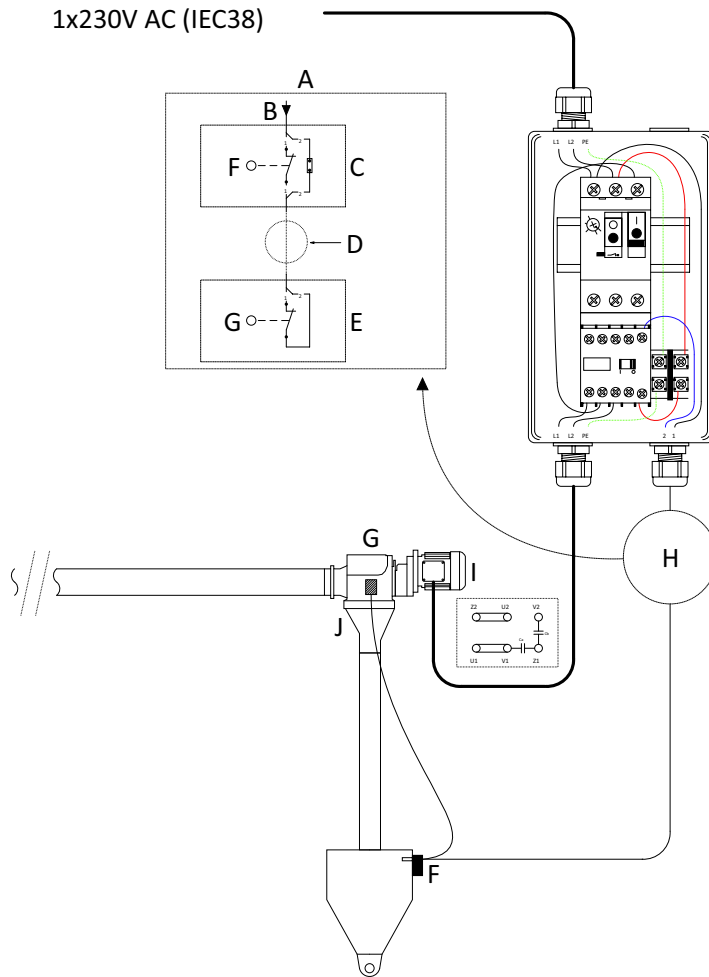

Flex-Auger example: max. 30° inclination

Reference	Description
A	Connection of start/stop condition
B	From motor starter
C	First start/stop condition
D	Connect extra start/stop conditions in series
E	Last start/stop condition
F	Level switch
G	Safety switch
H	Sw1
I	Sw2
J	Start/stop condition
K	FA power unit
L	Control unit

Sense of rotation of the auger: See arrow on the power unit.



ATTENTION:

- Compare the settings of the motor protection with the data on the motor label.
- See [Maximum cable lengths to the motors.](#)

Wiring diagram for 3 x 230 V

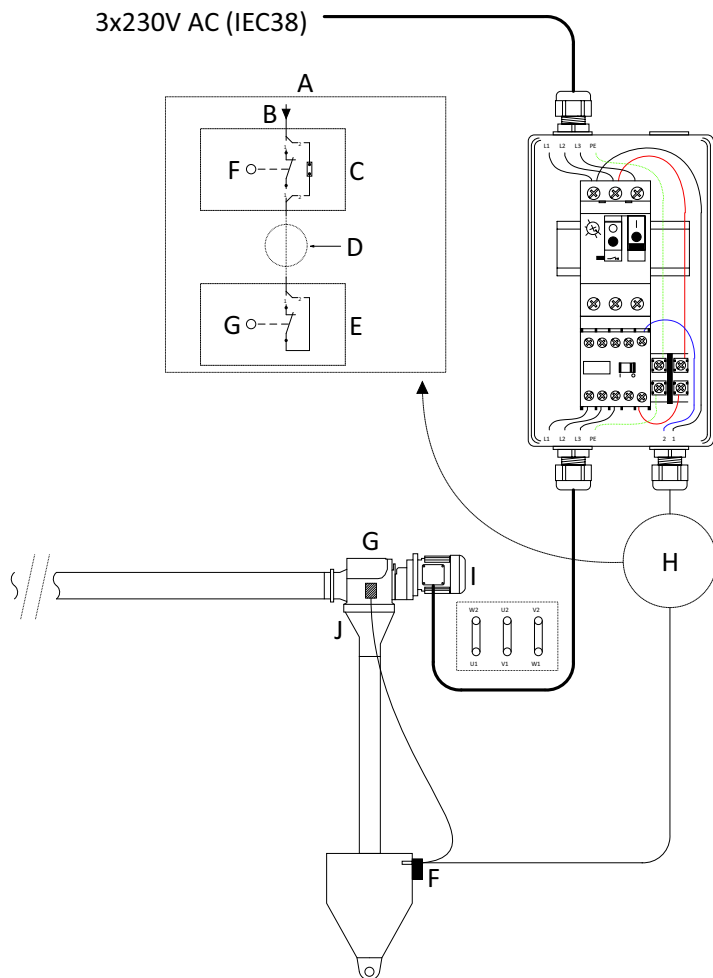

Flex-Auger example: max. 30° inclination

Reference	Description
A	Connection of start/stop condition
B	From motor starter
C	First start/stop condition
D	Connect extra start/stop conditions in series
E	Last start/stop condition
F	Level switch
G	Safety switch
H	Sw1
I	Sw2
J	Start/stop condition
K	FA power unit
L	Control unit

Sense of rotation of the auger: See arrow on the power unit.

ATTENTION:

- Compare the settings of the motor protection with the data on the motor label.
- See [Maximum cable lengths to the motors.](#)

Wiring diagram for 3 x 400 V

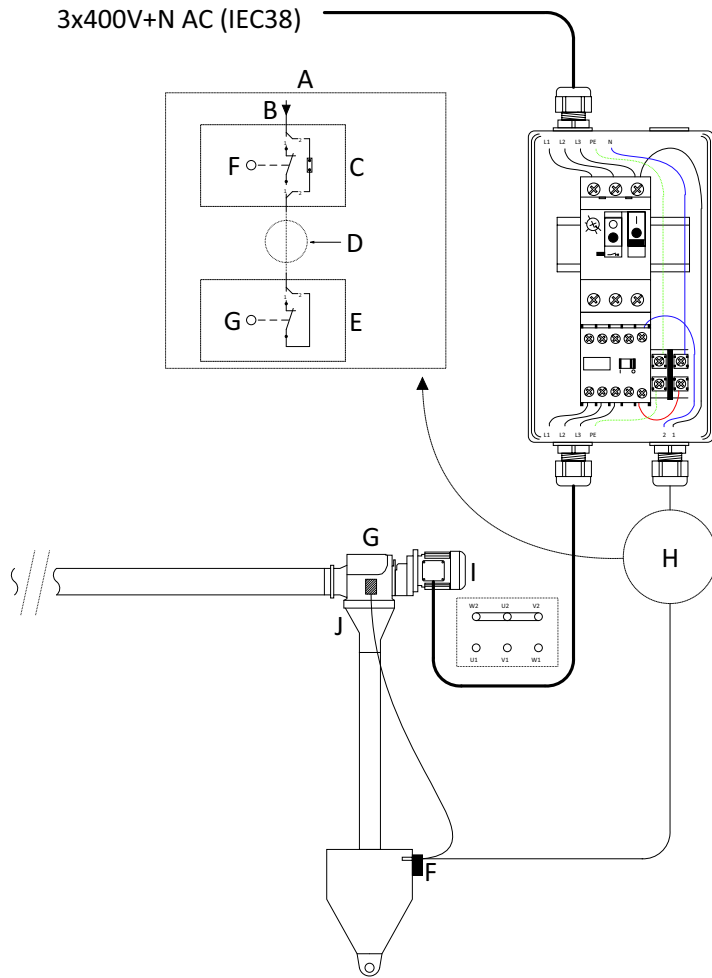

Reference	Description
A	Connection of start/stop condition
B	From motor starter
C	First start/stop condition
D	Connect extra start/stop conditions in series
E	Last start/stop condition
F	Level switch
G	Safety switch
H	Sw1
I	Sw2
J	Start/stop condition
K	FA power unit
L	Control unit

Sense of rotation of the auger: See arrow on the power unit.

ATTENTION:

- Compare the settings of the motor protection with the data on the motor label.
- See [Maximum cable lengths to the motors.](#)

Wiring diagram CDS feed supply system

Models 75, 90 and 125

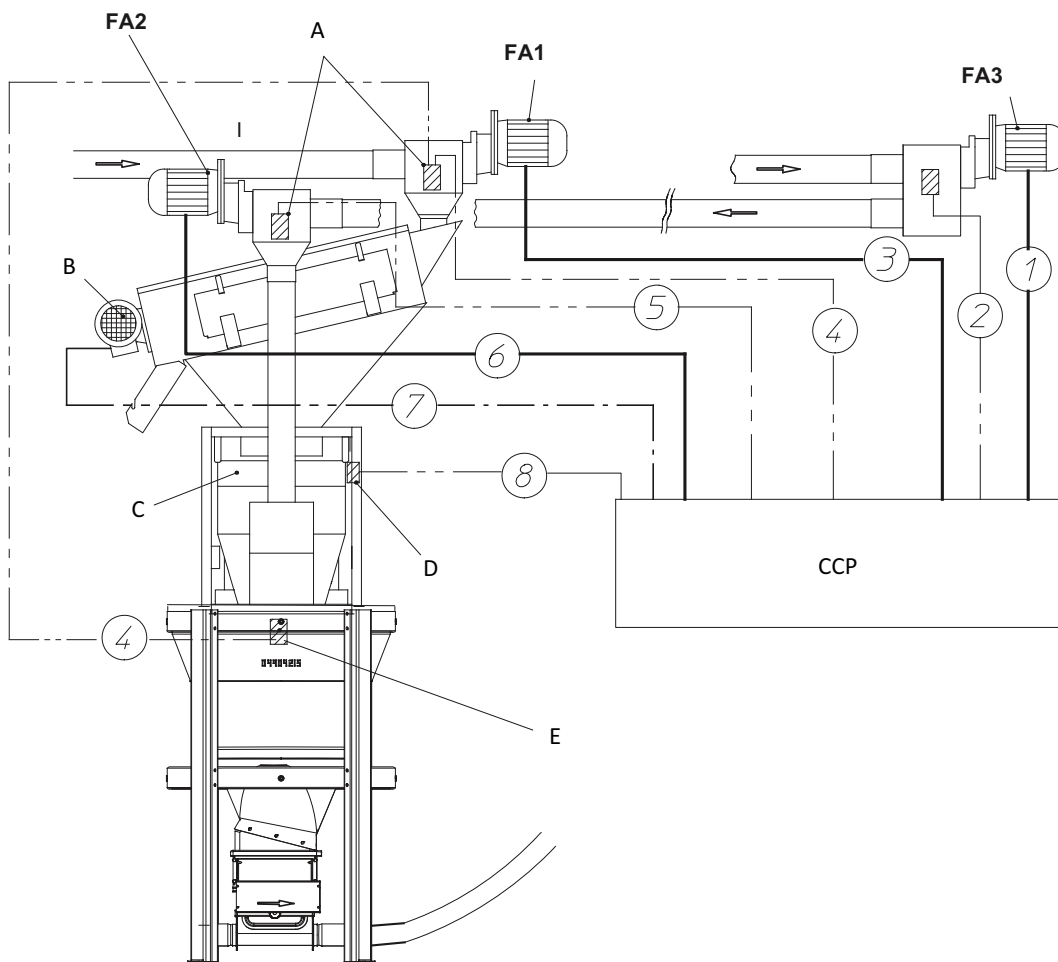

Reference	Description
A	Safety switch
B	Feed screener
C	Weigher
D	Impulse switch
E	Max. switch
FA	Flex-Auger
CCP	Central Control Panel
Cable types	Connection
1 = 3 x 2.5 + 2.5	From FA3 motor (only for model 125) to CCP
2 = 2 x 1.5	From FA3 safety switch to CCP
3 = 3 x 2.5	From FA1 motor to CCP
4 = 2 x 1.5	From max. switch weigher + FA1 safety switch to CCP
5 = 2 x 1.5	From FA2 safety switch to CCP
6 = 3 x 2.5 + 2.5	From FA2 motor to CCP
7 = 3 x 1.5 + 1.5	From feed screener motor to CCP
8 = 2 x 1.5 + 1.5	From impulse switch weigher to CCP



ATTENTION: See Maximum cable lengths to the motors.

Technical information automatic outlet

Wiring diagram

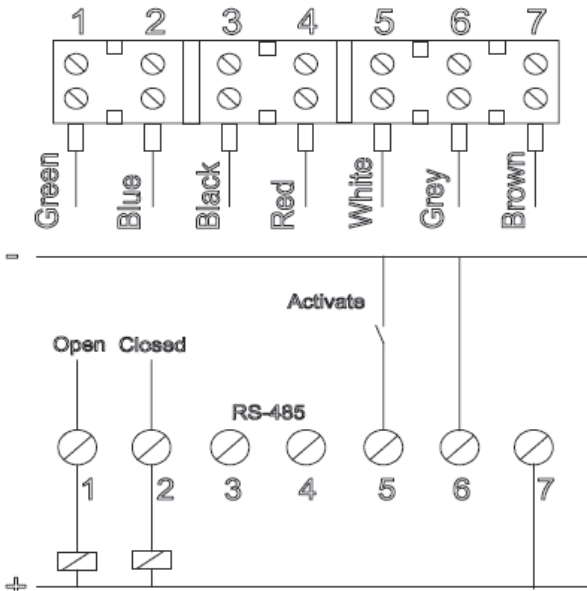



Connection	Colour	Signal
1	Green	Open signal
2	Blue	Closed signal
3	Black	RS-485 (MFII) not yet in use
4	Red	RS-485 (MFII) not yet in use
5	White (--)	Open signal with 0 V DC
6	Grey (-)	0 V DC
7	Brown (+)	24 V DC



NOTE: You receive feedback of the Open or Closed signals by digital input or relay.

- You can connect the signals coming from the automatic outlet to a 24 V DC relay.
- In MFII application: You can directly connect the feedback to an IDM.

LED lights overview

LED lights	Colour	Explanation
	Blue	Outlet is closed + 24 V DC.
	Slow blinking blue	Outlet is open.
	Fast blinking blue	Outlet starts running.
	Green	Motor is calibrating.
	Red	Motor is blocked (motor alarm).

Restart after a motor alarm

1. Remove the drop.
2. Remove any blocked feed.
3. Turn the 24 V DC off.
4. Turn the 24 V DC on.



NOTE: The calibration starts automatically. Then the LED light turns blue.

Technical specifications

Voltage	24 V DC \pm 20 %
Motor current: Stand-by	20 mA
Motor current: Open/Closed	150 mA
Motor current: Alarm	400 mA
24 V DC relay output	100 mA
Max. cable length	200 m
Min. cable section	0.5 mm ² – max.100 m
Min. cable section	0.75 mm ² – max. 200 m
 ATTENTION: After a voltage interruption in Open position, the input will not be checked for 15 seconds, so that the Open position is maintained for 15 seconds.	

Motor protection

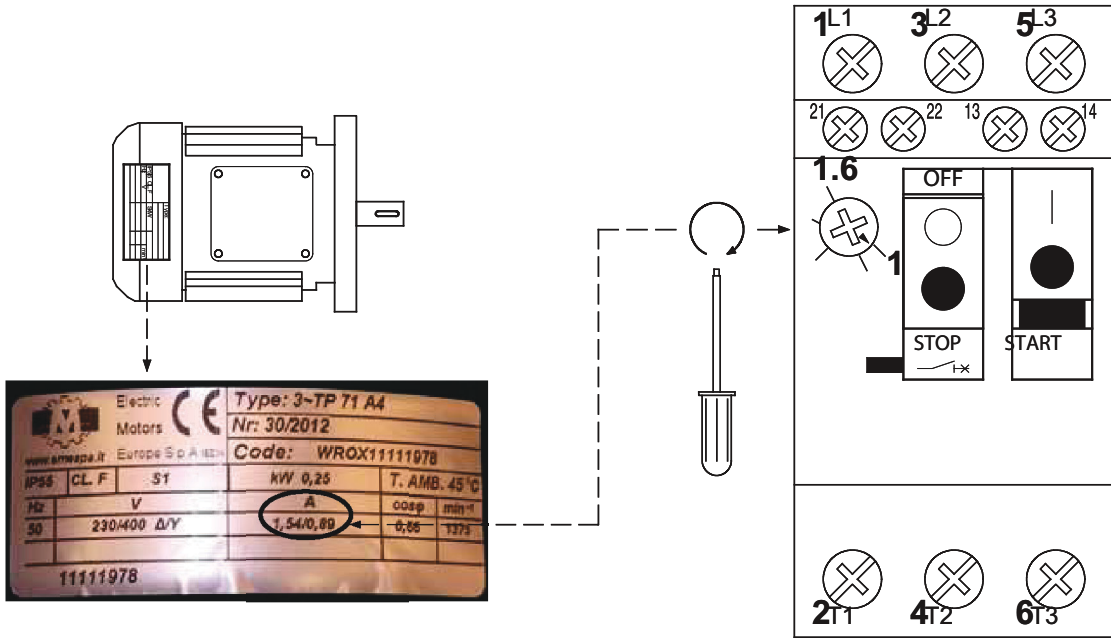

Maximum cable lengths to the motors

Calculation method:	IEC-HD 60364-5
Cable type:	PVC – XLPE – Silicon
Placing:	Open cable trough
Materials used:	Schneider Electric GV2 motor protections

 **ATTENTION: Please be aware that you have to follow the local regulations for your country!**

Motor Power (kW)	Net voltage	Protection	Max. cable length (m)	Wire gauge (mm ²)
0.12	3 x 230 V 50 Hz	GV2ME04	0 – 442	1.5
			443 – 736	2.5
			737 – 1179	4
	3 x 400 V 50 Hz	GV2ME03	0 – 1232	1.5
			1233 – 2053	2.5
			2054 – 3285	4
0.18	1 x 230 V 50 Hz	GV2ME07	0 – 110	1.5
			111 – 185	2.5
			186 – 297	4
	3 x 230 V 50 Hz	GV2ME06	0 – 174	1.5
			175 – 290	2.5
			291 – 464	4
	3 x 400 V 50 Hz	GV2ME05	0 – 492	1.5
			493 – 821	2.5
			822 – 1314	4
0.22	3 x 220 V 60 Hz 3 x 230 V 60 Hz	GV2ME06	0 – 167	1.5
			168 – 279	2.5
			280 – 446	4
	3 x 380 V 60 Hz 3 x 400 V 60 Hz	GV2ME05	0 – 471	1.5
			472 – 785	2.5
			786 – 1257	4
0.25	1 x 230 V 50 Hz	GV2ME07	0 – 110	1.5
			111 – 185	2.5
			186 – 297	4
	3 x 230 V 50 Hz	GV2ME06	0 – 174	1.5
			175 – 290	2.5
			291 – 464	4
	3 x 400 V 50 Hz	GV2ME05	0 – 492	1.5
			493 – 821	2.5
			822 – 1314	4
0.37	1 x 230 V 50 Hz	GV2ME08	0 – 69	1.5
			70 – 116	2.5
			117 – 185	4
	3 x 230 V 50 Hz	GV2ME07	0 – 111	1.5
			112 – 185	2.5
			186 – 297	4
	3 x 400 V 50 Hz	GV2ME06	0 – 308	1.5
			309 – 513	2.5
			514 – 821	4
0.45	3 x 220 V 60 Hz 3 x 230 V 60 Hz	GV2ME07	0 – 107	1.5
			108 – 178	2.5
			179 – 285	4
	3 x 380 V 60 Hz 3 x 400 V 60 Hz	GV2ME06	0 – 294	1.5
			295 – 491	2.5
			492 – 785	4

Motor Power (kW)	Net voltage	Protection	Max. cable length (m)	Wire gauge (mm ²)
0.55	3 x 230 V 50 Hz	GV2ME08	0 – 69	1.5
			70 – 116	2.5
			117 – 185	4
	3 x 230 V 50 Hz	GV2ME07	0 – 111	1.5
			112 – 185	2.5
			186 – 297	4
	3 x 400 V 50 Hz	GV2ME07	0 – 197	1.5
			198 – 328	2.5
			329 – 525	4
	3 x 400V 50 Hz	GV2ME06	0 – 308	1.5
			309 – 513	2.5
			514 – 821	4
0.75	1 x 230 V 50 Hz	GV2ME10	0 – 44	1.5
			45 – 73	2.5
			74 – 117	4
	3 x 230 V 50 Hz	GV2ME08	0 – 69	1.5
			70 – 116	2.5
			117 – 185	4
	3 x 400 V 50 Hz	GV2ME07	0 – 197	1.5
			198 – 328	2.5
			329 – 525	4
0.9	• 1 x 220 V 60 Hz • 1 x 230 V 60 Hz	GV2ME14	0 – 26	1.5
			27 – 44	2.5
			45 – 71	4
	• 3 x 220 V 60 Hz • 3 x 230 V 60 Hz	GV2ME10	0 – 42	1.5
			43 – 70	2.5
			71 – 113	4
3 x 380 V 60 Hz 3 x 400 V 60 Hz	GV2ME08	0 – 117	1.5	
		118 – 196	2.5	
		197 – 314	4	
1.1	3 x 230 V 50 Hz	GV2ME10	0 – 44	1.5
			45 – 73	2.5
			74 – 117	4
	3 x 400 V 50 Hz	GV2ME08	0 – 123	1.5
			124 – 205	2.5
			206 – 328	4
1.32	3 x 220 V 60 Hz 3 x 230 V 60 Hz	GV2ME14	0 – 26	1.5
			27 – 44	2.5
			45 – 71	4
	3 x 380 V 60 Hz 3 x 400 V 60 Hz	GV2ME08	0 – 117	1.5
			118 – 196	2.5
			197 – 314	4
1.5	1 x 230 V 50 Hz	GV2ME14	0 – 27	1.5
			28 – 46	2.5
			47 – 74	4
	3 x 230 V 50 Hz	GV2ME10	0 – 44	1.5
			45 – 73	2.5
			74 – 117	4
	3 x 400 V 50 Hz	GV2ME08	0 – 123	1.5
			124 – 205	2.5
			206 – 328	4
1.8	3 x 220 V 60 Hz 3 x 230 V 60 Hz	GV2ME14	0 – 26	1.5
			27 – 44	2.5
			45 – 71	4
	3 x 380 V 60 Hz 3 x 400 V 60 Hz	GV2ME10	0 – 74	1.5
			75 – 124	2.5
			125 – 199	4

Motor Power (kW)	Net voltage	Protection	Max. cable length (m)	Wire gauge (mm ²)
2.2	3 x 230 V 50 Hz	GV2ME14	0 – 27	1.5
			28 – 46	2.5
			47 – 74	4
	3 x 400 V 50 Hz	GV2ME10	0 – 78	1.5
			79 – 130	2.5
			130 – 208	4
2.64	3 x 380 V 60 Hz 3 x 400 V 60 Hz	GV2ME14	0 – 47	1.5
			48 – 78	2.5
			79 – 125	4

If the cable lengths are longer than the ones given in the tables above, take one of the following actions:

- Double the section of the PE (earth connection).
- Increase the section of the phases AND the PE (earth connection).
- Place an earth-leak circuit breaker.



ROXELL bvba - Industrielaan 13, 9990 Maldegem (Belgium)
Tel. +32 50 72 91 72 - info@roxell.com - www.roxell.com

ROXELL USA Inc. - 720 Industrial Park Road, Anderson MO 64831 (USA)
Tel. +1 417 845 6065 - info.usa@roxell.com - www.roxell.com

ROXELL Malaysia - No. 49, Jalan Permata 2/KS9, Taman Perindustrian Air Hitam, 41200 Klang, Selangor (Malaysia)
Tel. +60 3 3123 1767 - info.malaysia@roxell.com - www.roxell.com

ROXELL Россия - ООО «Рокселл» ОГРН 1157746055026
125167, Россия, город Москва, Ленинградский проспект, дом 37, корпус 9, помещение 653
Телефон: +7 495 983 30 15 - Адрес электронной почты: info.russia@roxell.com - www.roxell.com